

## VERY HIGH RESOLUTION RF CAVITY BPM\*

Marc Ross<sup>#</sup>, Joe Frisch, Linda Hendrickson, Douglas McCormick, SLAC, Stanford, CA 94309, USA,

Vladimir Vogel, Budker Institute of Nuclear Physics, Novosibirsk, Russia

Hitoshi Hayano, Junji Urakawa, KEK, Tsukuba-shi, Ibaraki-ken, Japan

### Abstract

Linear collider (LC) interaction region beam sizes and component position stability requirements are expected to be a few nanometers[1]. It is important to show that the related tolerances can be achieved, with an electron beam if possible. Using recently developed component stabilization technology, very high-resolution beam position monitors (BPM's), and the ultra-low emittance beam at the KEK ATF, we plan to demonstrate the required stabilization. Our first step is to develop high-resolution RF cavity beam position monitors, using either C or X band frequencies. A C-band cavity BPM with a resolution of 25 nm has been reported in tests at FFTB [2]. By correcting for the effects of non-axial trajectories and using both position and angle BPM movers, we expect to be able to demonstrate a resolution of 2 to 3 nm over a dynamic range of +/- 20 um. We report on the progress of the tests here.

### INTRODUCTION

Recent progress in accelerator performance has resulted in part from precision beam position monitors (BPM's). Third generation synchrotron radiation sources, such as the Swiss Light Source, are very close to achieving sub-micron beam stability over relatively long periods of many hours or even days.

Future accelerator projects, such as the linear collider, require large numbers of BPM's with 200 nm resolution and 1 um accuracy. Near the collision point, somewhat better resolution will be important. Given these developments, it is important to understand the limits on BPM performance and evaluate their role in the design of new machines. An RF cavity BPM, coupled with modern waveform processing, has been estimated to have resolution below one nanometer [3]. In this paper we illustrate the application of nanometer resolution BPM's and report on tests aimed at proving their performance.

### NANOMETER RESOLUTION

The theory of high resolution BPM's has been reported in [4]. C-band (6426 MHz) cavity BPM's, illustrated in figure 1, have been installed in the ultra-low emittance extraction line of the KEK Accelerator Test Facility ATF for the purpose of evaluating their performance and understanding the stability of the beam. Given the state of the art of storage ring and linear collider design, this appears at first to be beyond what is needed. These

BPM's have an estimated loss factor of  $3.9e10 \text{ J/C}^2/\text{mm}^2$  or about  $10^{-12} \text{ W}$  for a 1 nm offset with a beam of 1.6 nC, typical for the ATF. About 50% of this power is coupled out and can be mixed down to an IF waveform that is digitized. Table 1 summarizes the signal strength and the expected noise levels.

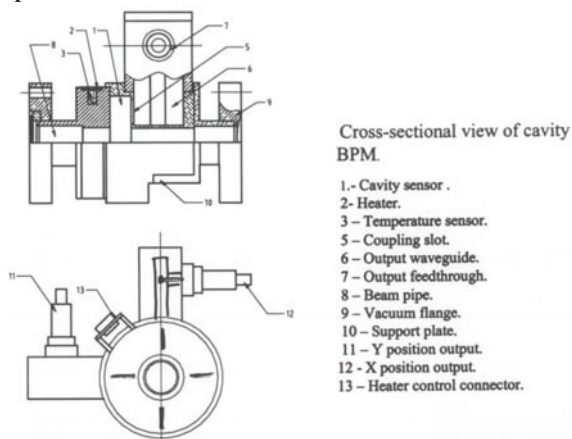

Figure 1: Schematic of the ATF extraction line C-band RF cavity BPM.

Table 1: Signals and noise in the cavity BPM system. The estimated thermal noise, at the digitizer, corresponds to less than one nanometer beam motion at  $10^{10}$  particles per bunch (ppb).

Circuit location	Estimated signal
E_dep ( $10^{10}$ ppb, 1nm offset)	$10^{-19} \text{ J}$
Energy coupled out	$5 \times 10^{-20} \text{ J}$
Output power	$5 \times 10^{-13} \text{ W}$ (-93dBm)
Downconvert/amp (50dB)	-43dBm
Into digitizer	3mV p/p
Thermal noise in band at cavity (10MHz)	-98dBm
Thermal noise with 3dB noise figure at digitizer	-45dBm

### Measurements

In [3], an experiment for proving BPM resolution is described. Using BPM's produced by the BINP group, we have reproduced that installation at the ATF. Because the signal emerging from the RF cavity BPM depends on the angle of the beam trajectory as well as its offset within the BPM, we have also included pitch and yaw movers on each BPM. Thus each BPM has 4 four independent remotely controlled degrees of motion,  $x$ ,  $y$ ,  $x'$ , and  $y'$ .

As in [4], we orthogonalize the sine-like and cosine-like ( $I/Q$ ) responses of the BPM's using the position and angle movers. Unfortunately, whereas the position motion

\* Work supported by US Department of Energy under contract DE-AC03-76SF00515

<sup>#</sup>mcrec@slac.stanford.edu

control  $(x,y)$  does not also move the angle of the monitor, the angle control is not perfectly centered at the BPM center and also moves the BPM position, making the  $I/Q$  determination a little less accurate. Nevertheless, once the response matrix of the mover controls and the  $I/Q$  signals is known, it is straightforward to find the trajectory through the BPM which produces minimum or no power out on average.

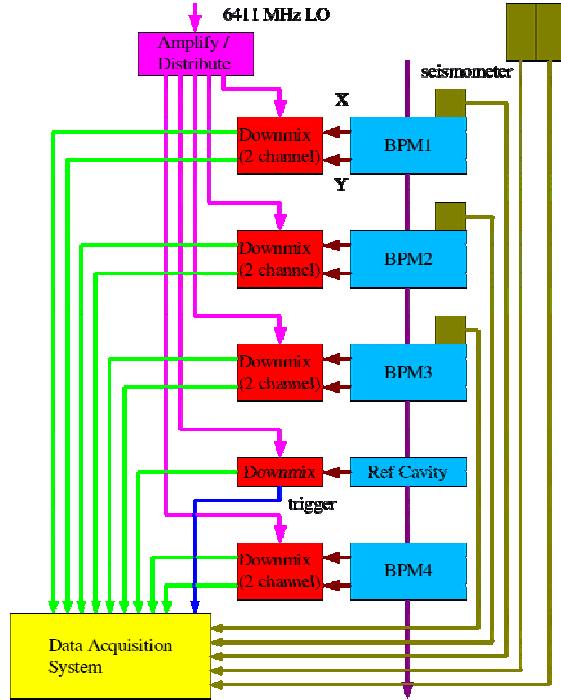

Figure 2: Schematic of the high resolution BPM test equipment, showing the BPM placement along the beamline and the signal processing electronics. In this experiment seismometer vibration monitors (shown on the right) were used to check the motion of the BPM's and BPM supports.

In the ATF extraction line, where these measurements were made, the beam repetition rate is 1.5 Hz, the beam size  $\sigma_x/\sigma_y$  is 50/5  $\mu\text{m}$ , the beam energy  $E_b$  is 1.3 GeV and typical beam pulse to pulse position variation is 3  $\mu\text{m}$ .

Figure 2 shows the signal processing system used to acquire waveforms from each BPM. Care is taken to keep the noise figure low and to use a narrow band system. The final 15 MHz IF is digitized using 12 bit 100 MHz digitizers. Figure 3 shows the digitized waveforms from the beam trigger, the reference cavity, and the  $x$   $y$  output from one of the BPM's. Initial commissioning of the system is underway and resolution measurements will be done soon.

## INTERACTION REGION STABILIZATION

The two sets of focusing magnets that are aligned with the entrance to the linear collider detector must be stabilized with respect to each other to within a few

nanometers [5]. Beam tests, using SLC and FFTB, that prove the performance of development stabilization systems have been proposed [6]. In the SLC-based proposal, for example, the key issue is to demonstrate that two beams can be kept in collision with the help of prototype active stabilization systems.

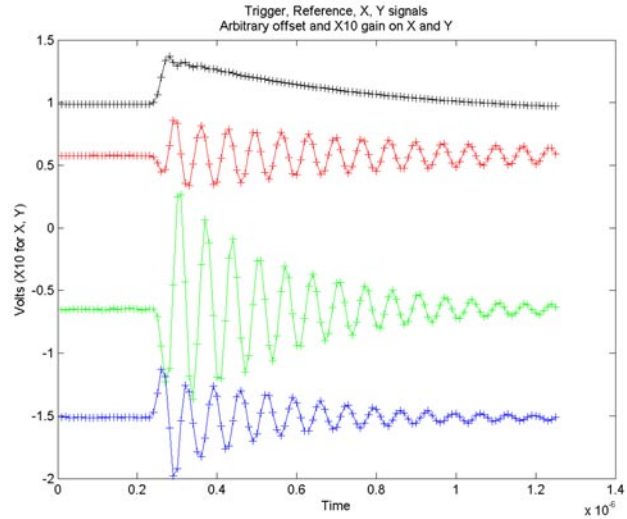

Figure 3: Digitized IF waveforms from the RF cavity BPM's. From top to bottom, the trigger, reference cavity IF and  $x$   $y$  IF waveforms are displayed. The time base is in  $\mu\text{s}$ .

In the ATF extraction line, using nanometer resolution BPM's, we will be able to validate the performance of stabilization system prototypes. One of the stabilization systems in development uses precision inertial sensors and an active 'extended object' feedback process. Other stabilization systems use a 'reference object' and 'optical anchor' to indirectly refer the two sets of focusing magnets to each other [7]. The ATF test will use two systems like the one illustrated in figure 2, with a total of 6 RF cavity BPM's with their support movers. The supports will be stabilized using prototype interaction region stabilization feedback. In this experiment, the beam and the BPM's function as a nanometer stability alignment reference.

## FEEDBACK

The ATF nanometer BPM's will also be used to demonstrate the stabilization of the trajectory of a long, multi-bunch train [8]. In this experiment, broadband electronics will be coupled with the cavity BPM to provide a correction signal for a feedback kicker. It will be possible to stabilize, to within a few nanometers, the bunches in the train that follow roughly the first 60 ns.

## CONCLUSIONS

Interferometers, capable of measuring distances with precision, are not able to provide nanometer resolution measurements with respect to a reference line. There is no presently available technology capable of making alignment measurements with respect to a straight-line

reference at the nanometer level. Using a high energy electron beam and nanometer resolution BPM's we expect to develop the technology to perform this sort of measurement. The beam and BPM's are then a tool used to test and validate mechanical engineering designs.

## REFERENCES

- [1] "The Zeroth Order Design Report for the Next Linear Collider", <http://www-project.slac.stanford.edu/lc/ZDR/Zeroth.html>
- [2] T. Slaton *et al.*, "Development of Nanometer Resolution C Band Radio Frequency Beam Position Monitors in the Final Focus Test Beam", XIX Linac Conference, 08/1998.
- [3] Z. Li, *et al.*, "Cavity BPM with Dipole-Mode-Selective Coupler", this conference.
- [4] M. Ross, *et al.*, "RF Cavity BPM's as Beam Angle and Beam Correlation Monitors", this conference.
- [5] J. Frisch, *et al.*, 'Inertial Sensor Development for Active Vibration Stabilization', this conference.
- [6] Experiment proposal for the 'LINX' project, <http://www-project.slac.stanford.edu/lc/linx/>
- [7] Proceedings of the ICFA Nano-beam workshop, <http://icfa-nanobeam.web.cern.ch/icfa-nanobeam/>
- [8] P. Burrows, *et al.*, "Feedback on Nanosecond Timescales for Linear Colliders: Results from First Beam Tests at the NLC Test Accelerator at SLAC", this conference