

The Linac Coherent Light Source[†]

John N. Galayda

Stanford Linear Accelerator Center, Menlo Park, California 94025

Abstract. A collaboration of scientists from SLAC, UCLA, Los Alamos National Laboratory, Brookhaven National Laboratory, and Argonne National Laboratory have proposed to build the Linac Coherent Light Source (LCLS) facility, a free-electron laser (FEL) on the SLAC site, spanning photon energies 0.8-8 keV. The laser output will be 8-10 GW with pulse lengths 230 fsec or less. The LCLS will offer unprecedented experimental opportunities in the areas of atomic physics, chemical dynamics, plasma physics, nanoscale dynamics, and biomolecular imaging. SLAC has proposed to begin engineering design of the laser in 2003, leading to project completion in 2008. The laser produces x-rays by the self-amplified spontaneous emission (SASE) process: an intense, highly collimated pulse of 14.5 GeV electrons, traveling through a 122 m-long undulator magnet system, is induced by its own synchrotron radiation to form sub-nanometer-scale bunches. The bunching process enhances the coherence and hence the intensity of the emitted synchrotron radiation. The process is analogous to the instability of a high-gain amplifier; the “noise” signal that seeds the instability is the shot noise in the electron beam.

SELF-AMPLIFIED SPONTANEOUS EMISSION

Synchrotron radiation is produced by an energetic charged particle as it is deflected by an externally applied magnetic field. The properties of synchrotron radiation produced in storage rings and free-electron lasers may be derived from the Lienard-Wiechert potentials of a relativistic accelerating charge[1]. Quantum fluctuations in the emission of synchrotron radiation contribute a random component to the momentum of radiating electrons; however, the properties of the synchrotron radiation and the mechanism for its amplification in a free-electron laser may be rigorously understood in a classical treatment[2]. A description of the self-amplified spontaneous emission (SASE) process, along with a rather complete list of references to key publications in free-electron laser research, may be found in Chapter 4 of the Linac Coherent Light Source Conceptual Design Report[3].

A useful radiation source, and one of particular relevance to free-electron lasers (FELs), is produced by passing an electron beam through an *undulator* magnet. The field of such a magnet varies sinusoidally in z with peak field B_0 and period λ_u :

$$\bar{B}(x, y = 0, z) = (0, B_0 \cos(k_u z), 0); \quad k_u = 2\pi / \lambda_u \quad (1)$$

[†] Work supported by DOE contract DE-AC03-76SF00515

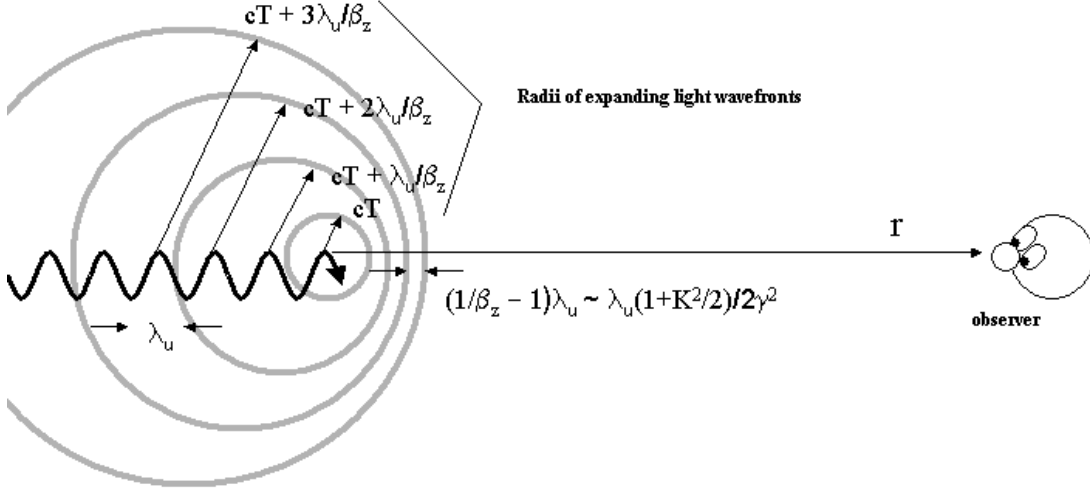

FIGURE 1. An electron moving in an undulator with period λ_u may be envisioned as emitting one wavefront of synchrotron radiation for each undulator period. The electron travels a distance $\beta_z \lambda_u$ as the wavefronts travel a distance λ_u , resulting in radiation with wavelength $(1/\beta_z - 1)\lambda_u$, as seen by an observer on-axis. The factor K appears as a result of replacing β_z^2 with $\beta^2 - \langle \beta_x^2 \rangle$, and applying equation 2.

An electron entering the undulator magnet with high momentum in the z direction will be deflected so as to oscillate in the x direction. Here we assume that the maximum deflection of the electron is sufficiently small that its motion is, to a good approximation, sinusoidal. Following Hofmann's exposition[4], the transverse deflection $\beta_x(t')$ of the electron is customarily expressed in terms of the undulator strength parameter K , defined below:

$$\dot{\beta}_x(t') \cong -\left(\frac{ec\beta_z B_0}{mc\gamma}\right) \cos(k_u \beta_z ct')$$

(2)

$$\beta_x(t') \cong -\left(\frac{ec\beta_z B_0}{mc\gamma}\right) (k_u \beta_z c)^{-1} \sin(k_u \beta_z ct') \equiv -\frac{K}{\gamma} \sin(k_u \beta_z ct')$$

The electric field of undulator radiation produced at retarded time t' by a single electron travels a distance r to an observer, arriving at time t as illustrated in figure 1. In the far-field approximation, the on-axis field is

$$E_x(t) \cong \left(\frac{4e^2 B_0 c \gamma^3}{4\pi\epsilon_0 (1 + K^2/2)^2 mc^2}\right) \frac{1}{r} \cos\left(\frac{2\pi}{\lambda_u} \frac{2\gamma^2}{(1 + K^2/2)} \beta_z ct + \text{const.}\right) \quad (3)$$

One can see that the radiation wavelength is equal to the undulator period λ_u , shortened by the Doppler shift factor $(1+K^2/2)/2\gamma^2$ for β near 1.

If synchrotron radiation from N electrons reaches the observer at time t , one may add their contributions to the observed electric field, each including its appropriate phase factor in the cosine function. It is convenient to replace the cosine in equation 3 by $e^{-i\omega t}$ so that the total electric field produced by N electrons may be expressed as

$$E_{tot}(t) = E_x(t) \sum_{j=1}^N \exp(i\phi_j) \quad (4)$$

In a non-laser synchrotron light source such as the SPEAR ring at SLAC, the electrons are randomly distributed, on a length scale of the order of the synchrotron radiation wavelength. In this case $\langle E(t) \rangle = 0$ and the average power is given by $\langle E^2 \rangle$, and is proportional to N . However, if the electrons were distributed in short bunches with separation equal to the wavelength of the undulator radiation, the summation over phase factors can approach its maximum value of N . Since the radiated power is proportional to N^2 , and N can be of the order of 10^{10} , an enormous increase in radiated power can be realized, as compared to a conventional synchrotron source.

A free-electron (FEL) laser exploits the dynamics of electron beams to bring about the bunching necessary to achieve dramatic power enhancement. The bunching results from the interaction of the electrons with their own synchrotron radiation in addition to the undulator magnet field. Random fluctuations in the electron distribution produce corresponding fluctuations in the spontaneous synchrotron radiation. The strongest of these fluctuations begin to bunch the electrons, further intensifying the radiation field. In essence, the process amplifies a particular Fourier component of the shot noise in the electron beam current, determined by the wavelength of the undulator radiation. For this reason the process is called *self-amplified spontaneous emission* (SASE). Under ideal conditions the process can fully bunch the electrons, at which point the output power reaches its saturation level. The gain of the SASE process is characterized by the distance the electron beam travels as the synchrotron radiation power is amplified a factor of e . This distance, the *gain length*, varies from 2.4 meters for 0.8 keV photons to about 5.8 meters for 8 keV x-rays in the Linac Coherent Light Source (LCLS) design. Saturation of the SASE process should be complete in less than 20 gain lengths.

SASE is a single-pass phenomenon. For a properly conditioned electron beam, a resonant cavity for the synchrotron radiation is not necessary. However a SASE FEL can serve as an amplifier for a light pulse from an external source. Furthermore, the bunching of electrons by SASE can produce Fourier components of the beam current at harmonics of the fundamental FEL wavelength. This results in strongly enhanced emission of synchrotron radiation at these harmonics. Schemes to enhance harmonic

generation by seeding with an external laser or with synchrotron radiation is presently the subject of active study.

It is quite challenging to produce an electron beam with properties necessary for a SASE FEL. For an 8 keV FEL such as the Linac Coherent Light Source, peak currents in the range 1,000-4,000 amperes are necessary. The electron beam must remain within the synchrotron radiation fan in order to be bunched. This implies that the electron beam emittance must be comparable to that of the photon beam, $\lambda/4\pi$. Finally the energy spread of the electron beam must be small, of the order of 10^{-5} . For lasing at 8 keV, these conditions can be satisfied by adding a high-quality electron source to the SLAC linac, and accelerating this beam to 14.35 GeV.

The temporal coherence of a SASE FEL is limited by its high gain; only L_g/λ_u wavefronts are produced in one gain length L_g . Hence the bunching process can proceed independently for wavetrains of this length, within a single 230 fsec electron bunch. Of course, if a SASE FEL is used to amplify a seed pulse, the temporal coherence of the seed is imprinted on the FEL output.

THE LINAC COHERENT LIGHT SOURCE PROJECT

A SASE FEL is, at this time, the most straightforward means of creating gigawatt-level coherent light pulses in the 0.1 nanometer wavelength range. However, the necessary electron accelerator and undulator system are far beyond the "tabletop" paradigm in size and cost. In 1992[5], C. Pellegrini proposed the use of the last kilometer of the SLAC linac to construct a 0.1 nm SASE free electron laser. This makes possible a cost savings of about \$300M compared to construction of a dedicated linac. A study group was organized at SLAC to determine the feasibility of this proposal. This study group expanded, and now includes researchers from Lawrence Livermore National Laboratory, Los Alamos National Laboratory, Brookhaven National Lab, Argonne National Laboratory and the University of California-Los Angeles. The LCLS Collaboration completed a design study of an x-ray FEL, *LCLS Design Study Report*[6] in 1998. Since then, the Collaboration has conducted experimental investigations of high-performance electron guns and successfully completed experimental tests of the FEL process. Funds for R&D were provided by DOE in the amount \$1.5M/year from 1999 to 2002. A more detailed design for the LCLS has been published in the LCLS Conceptual Design Report[7]. The LCLS Construction Project will begin in fiscal year 2003, when it enters the Project Engineering Design phase. It is expected that, in FY2005, it will be possible to order items with long delivery times, such as the undulator magnets and components for the photoinjector. Civil construction will begin in 2006. Commissioning tests of the accelerator systems will begin in 2006, and laser tests will begin in 2008. By the end of 2008, the laser and all experiment facilities will be complete. The Total Estimated Cost for construction of the LCLS is \$221M. When it is complete, the LCLS will provide spatially coherent beams of x rays from 0.8 keV to 8 keV. Peak output powers of about 8 GW are expected. Initially, the LCLS will produce x-ray pulses with duration 230 fsec or less.

Upgrades to pulses in the 10 fsec range are under development. **Table 1** lists some key parameters of the LCLS.

Though the extraordinary x-ray beam of the LCLS will itself be the subject of study at first, much effort has already been devoted to plans for use of the LCLS for research in atomic physics, chemistry, materials science, plasma physics and biology[8]. The LCLS will be used as a “pump” to create extraordinary states of matter, such as atoms with all inner shell electrons stripped away; or “warm, dense plasma,” solids raised instantly to temperatures approaching 10 eV. The LCLS will also serve as a probe of chemical dynamics. By determining interatomic separations as they evolve on a femtosecond time scale, the LCLS may be used, in effect, for “freeze-frame” photography of atoms as they form and break molecular bonds. The intensity of the focused x-ray beam will be such that structure determination of samples as small as a single virus particle or perhaps a single protein molecule become feasible.

TABLE 1. Characteristics of the LCLS x-ray beam

Photon Beam Parameters	Lower Limit	Upper Limit	Units
Photon energy	0.8	8	keV
Photon wavelength	1.5	0.15	nanometers
Coherent photons/pulse	10.2	1.8	$\times 10^{12}$
Peak brightness	0.78×10^{32}	12.1×10^{32}	Photons/(sec mm ² mrad ² 0.1% BW)
Average brightness(120 Hz)	0.39×10^{21}	2.8×10^{21}	Photons/(sec mm ² mrad ² 0.1% BW)
Peak coherent power	10.6	8	GW
Transverse beam size, rms	37	27	microns
Beam divergence, rms	3.2	0.39	microradians
Electron Beam	Lower Limit	Upper Limit	Units
Electron beam energy	4.54	14.35	GeV
Electron pulse duration	230	230	Femtoseconds
Electron beam peak current	3,400	3,400	amperes
SASE gain length	2.4	5.8	meters

A physical description of the LCLS begins with the injector linac, a 150 MeV accelerator that will be located in a “spur” tunnel that joins the main linac tunnel at the 2 kilometer point (“Linac 0” in figure 3.). A key component in the injector linac and, indeed, for the whole of the LCLS is the photocathode RF gun. The gun is a 2856 MHz, 1.6-cell resonant structure that was designed, constructed and tested by collaborators from SLAC, Brookhaven and UCLA[9]. This gun is capable of producing a 1-nanocoulomb pulse of 7 MeV electrons, 10 psec long, with emittance necessary to support the SASE process at 0.15 nanometers. Current from this gun is switched by illuminating the copper cathode with a 500 microjoule pulse of UV light. It is expected that a Ti:sapphire laser system will be used for this purpose in the LCLS. This laser must produce a pulse with very flat profile both temporally and transversely. A very fast risetime and falltime are important to produce a uniform charge density (and hence correctable space-charge forces) in the electron beam. Commercially available lasers routinely meet LCLS power specifications, with the exception of the required 120 Hz repetition rate.

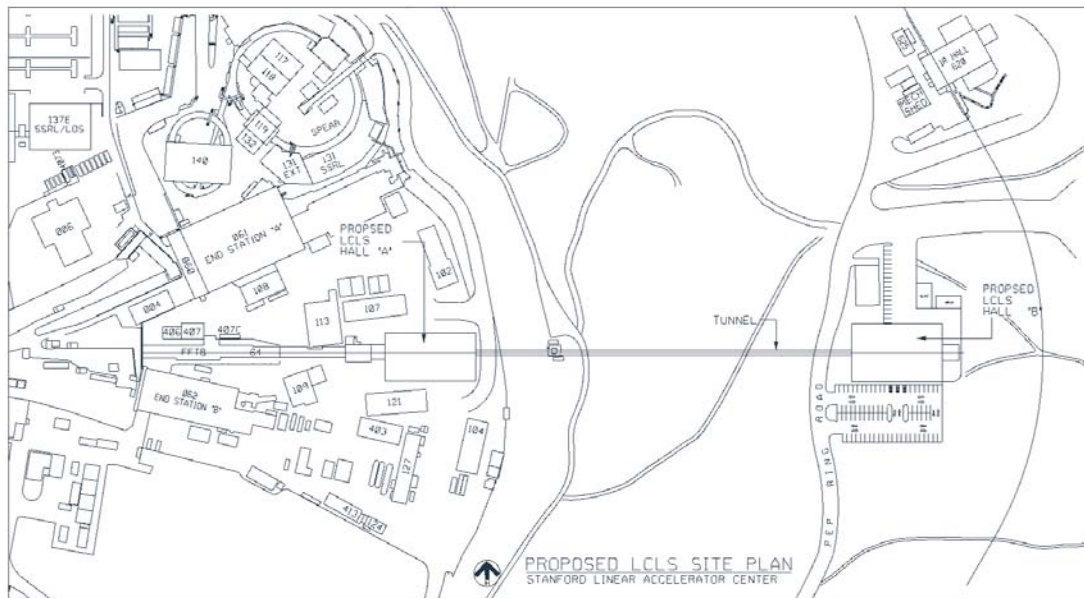

FIGURE 2. Site plan for the Linac Coherent Light Source. The linac provides electrons to End Station “A” as well as to the LCLS undulator, housed in the Final Focus Test Beam (FFTB) building. Experiment Hall A is attached to the FFTB. X rays from the LCLS may be directed through a tunnel to Experiment Hall B, 322 meters from the undulator.

The 150 MeV electron beam is injected to the SLAC linac to be accelerated to a maximum of 14.35 GeV. During the acceleration process, the 100-ampere current pulse must be compressed in several stages to reach 3,400 amperes. Pulse compression in the electron beam is achieved in close analogy with compression of a laser pulse: an energy “chirp” is applied to the electron beam, so that electrons at the rear of the bunch are more energetic than those in the front. When the electron beam passes through a chicane of four bending magnets, the more energetic electrons follow a more direct trajectory and nearly overtake the leading electrons. This conceptually simple process is made difficult by a phenomenon closely related to the SASE mechanism; in passing through the chicane bends, the electrons emit synchrotron radiation. For radiation wavelengths comparable to the length scale set by the bunch and any current fluctuations in the bunch, there can be a high degree of coherence in the synchrotron radiation and hence an enhanced energy loss and spreading in the electron beam. Coherent synchrotron radiation effects can amplify current fluctuations and energy errors in the bunch[10]. With careful design, compression can be accomplished without undue damage to the electron beam properties. The LCLS design incorporates two bunch compressors, one at the 250 MeV point and the other at the 4.5 GeV point in the linac(Bunch Compressor 1 and Bunch Compressor 2 in figure 3.). The compressive effects of other bends in the beam path must be controlled, however, including those at the 150 MeV point and the “dogleg” bends at the end of the linac. After acceleration, the electron beam is passed through a 121-meter undulator channel. The channel, designed at the Advanced Photon Source of Argonne National Laboratory, incorporates thirty-three 3.4-meter long hybrid permanent magnets, which

must meet stringent field requirements to maintain the necessary collinearity between the electron beam and the photon beam. The channel incorporates focusing magnets and a variety of diagnostics for the electrons and x rays.

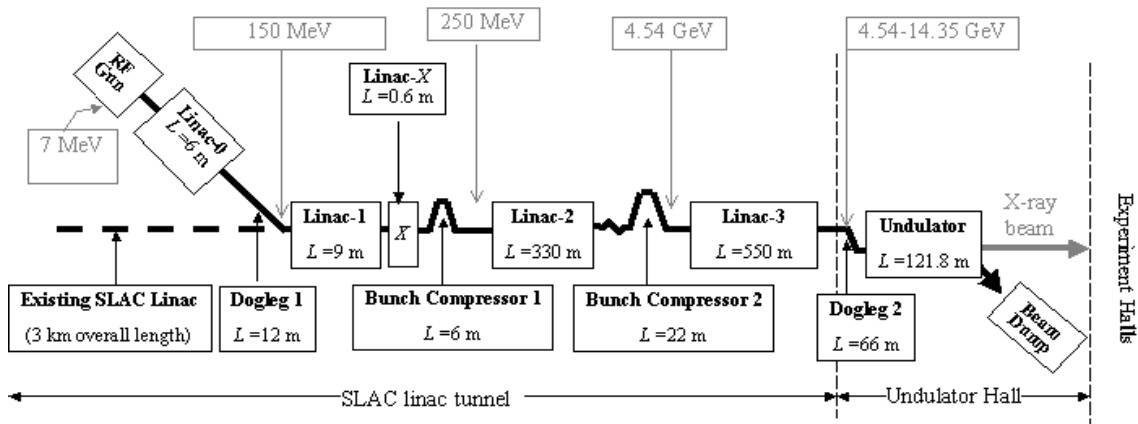

FIGURE 3. Schematic layout of the LCLS. Electron beam energies at various stages of the accelerator are indicated at the top of the figure. Bends in the electron beam path, i.e. the “doglegs” and bunch compressors, are designed to compress the electron bunch, raising its peak current from 100A to 3,400A.

An 8 GW pulse of coherent radiation emerges from the undulator channel, with an r.m.s. beam size of 30 microns and an opening angle of 0.5 microradian at 0.15 nanometers. The ability of optics to withstand this beam will itself be an area of research once the LCLS is operational; design of robust optics for 1.5 nanometer radiation is especially challenging. The x-ray transport, optics and diagnostics system for the LCLS will be constructed at Lawrence Livermore National Laboratory[11]. The optical device located closest to the source point will be a differentially-pumped gas cell for controlled attenuation of x-ray beam intensity. Prototypical optical elements to focus, monochromatize and split the x-ray beam will be included in the scope of the LCLS Project.

LCLS experimental facilities will be located in two experiment halls, as indicated in Figure 2. Hall A is located 40 meters from the end of the undulator and will house up to four x-ray enclosures. The x-ray beam may pass through Hall A to Hall B, located 322 meters from the undulator exit. The divergence of the x-ray beam is such that materials traditionally used for x-ray optics at synchrotron sources may be employed. Low-Z materials are favored for optics in the Near Hall.

FUTURE DEVELOPMENTS FOR THE LCLS

Ongoing efforts to shorten the LCLS x-ray pulse duration and to improve the temporal coherence will continue into the post-commissioning phase. The LCLS Project goals, listed in Table 1, call for a pulse duration of 230 fsec for the electron beam. The x-ray pulse waveform need not replicate that of the electron beam. It is

likely to contain spikes of power with varying amplitude and coherence length of the order of $100-200\lambda$ [12]. Indeed, the x-ray pulse may even be considerably shorter than the electron current pulse. Since the SASE process starts from shot noise in the beam, there can be considerable variation in light output from pulse to pulse. After SASE lasing has been achieved, several methods for control of the properties of the x-ray pulse will be explored by seeding the SASE process with a lower-power x-ray pulse. Seeding can be used to improve temporal coherence[13], to reduce the duration of the fully amplified x-ray pulse[14], or to generate harmonics of the seed pulse[15]. The seed pulse can itself be extracted from synchrotron radiation produced in the first few undulators of the LCLS. However, seed pulses from other sources, such as those described at this conference, would be an attractive alternative; it is to be hoped that the LCLS will provide a point of convergence for heretofore disjoint areas of research in x-ray lasers.

REFERENCES

1. Hofmann, A., "Properties of Synchrotron Radiation", in the proceedings of the *CERN Accelerator School – Synchrotron Radiation and Free Electron Lasers*, edited by S. Turner, CERN 98-04, 3 August 1998
2. Schroeder, C., Pellegrini, C., and Chen, P., "Quantum Fluctuations in Free-Electron Lasers", in *Quantum Aspects of Beam Physics, - 18th Advanced ICFA Beam Dynamics Workshop, Capri, Italy 15-20 October 2000*, edited by Pisin Chen, World Scientific Publishing Co., May 2002 (ISBN 981-02-4950-0)
3. Chapter 3, "FEL Physics", *Linac Coherent Light Source (LCLS) Conceptual Design Report*, SLAC-R-593, April 2002, <http://www-ssrl.slac.stanford.edu/lcls/CDR/>
4. A. Hofmann, op. cit, section 4
5. Pellegrini, C., "A 4 to 0.1 FEL based on the SLAC Linac", in the proceedings of the *Workshop on Fourth Generation Light Sources, February 24-27 1992, SSRL-92-02*, pp. 364-375, 1992
6. Arthur, J. et al., *LCLS Design Study Report*, SLAC-R-0521,
7. *Linac Coherent Light Source (LCLS) Conceptual Design Report*, SLAC-R-593, April 2002, <http://www-ssrl.slac.stanford.edu/lcls/CDR/>
8. Shenoy, G. and Stohr, J., *LCLS – the First Experiments*, October 2000 http://www-ssrl.slac.stanford.edu/LCLS/papers/LCLS_Experiments_2.pdf,
9. Palmer, D. T. , et al., "Emittance Studies of the BNL/SLAC/UCLA 1.6-cell photocathode gun", in *Proceedings of the 1997 Particle Accelerator Conference, Vancouver, B.C., Canada, 12-16 May 1997*, p.2687
10. Heifets, S., Krinsky, S. and Stupakov, G., CSR Instability in a Bunch Compressor, SLAC-PUB-9165, March 2002
11. *LCLS Conceptual Design Report*, Chapter 9, op. cit.
12. *LCLS Conceptual Design Report*, Chapter 4, pg. 4-9, op. cit.
13. Feldhaus, Saldin, E. I., Schneider, J. R., Schneidmiller, E. A., "Possible Application of X-ray Optical elements for reducing the spectral bandwidth of an X-ray SASE FEL, *Opt. Commun.* **140**, pp. 341-352, 1997
14. Schroeder, C. B., Pellegrini, C., Reiche, S., Arthur, J. and Emma, P., "Chirped-Beam Two-Stage SASE-FEL for High Power Femtosecond X-ray Pulse Generation", , in *Proceedings of the 2001 Particle Accelerator Conference*, P. Lucas and S. Webber, editors, IEEE Operations Center, Piscataway, NJ, 2001 pp. 2757-2759.
15. Brefeld, W., Faatz, B., Feldhaus, J., Korfer, M., Kryzwiniski, J., Moller, T., Pflueger, J., Rossbach, J., Saldin, E., Schneidmiller, E. A., Schreiber, S., and Yurkov, M. V., "Development of a Femtosecond X-Ray SASE FEL at DESY", *Nuc. Inst. Meth. A*, 483, pp 75-79 (2002).