

# DESIGN OF A 30 GHZ DAMPED DETUNED ACCELERATING STRUCTURE

SLAC-PUB-9777

M. Dehler<sup>†</sup>, R.M. Jones<sup>‡</sup>, N.M. Kroll<sup>‡</sup>, R.H. Miller<sup>‡</sup>, I. Wilson<sup>†</sup> and W. Wuensch<sup>†</sup>

<sup>†</sup> PS Division, CERN, Geneva, Switzerland; <sup>‡</sup> Stanford Linear Accelerator Center, California, USA

## Abstract

Within the framework of the SLAC/CERN studies of 30 GHz linear colliders, an attempt has been made to scale as closely as possible the existing X-band NLC damped detuned accelerating structure to 30 GHz. A simple scaling was not possible because of mechanical and RF constraints. The 30 GHz design has 101 cells and a minimum aperture of 3.4 mm. In order to obtain acceptably small values for both the single-bunch transverse wakefield and the long-range multibunch wakefield a relatively large non-linear variation of the iris thickness was introduced in addition to the iris diameter variation. The resulting wakefield has a short-range value of 1290 V/pC/mm/m and a long range value below 10 V/pC/mm/m.

## 1 INTRODUCTION

RF frequencies around 30 GHz are being considered for both the Compact Linear Collider (CLIC) and the 3-5 TeV e+e- linear collider studies [1,2] to allow operation with high accelerating gradients (100-200 MV/m). In order to reach the required luminosities these machines have to be operated with multiple bunches per rf pulse. There is therefore a common requirement for a 30 GHz multibunch accelerating structure. Because of the large amount of design and experimental verification (ASSET) work that has been invested by SLAC in their X-band Damped Detuned Structure (DDS) it was decided to see to what extent this structure could be scaled to 30 GHz.

The basic approach was to scale as closely as possible, the existing SLAC X-band design but taking into account mechanical and RF constraints specific to 30 GHz. Some design choices have been biased in favour of the existing CLIC parameters ( $8 \times 10^9$  particles per bunch, a bunch spacing of 30 rf cycles (1 ns) and a loaded accelerating gradient of 100 MV/m) which require a transverse wakefield reduction to about 1% at the second bunch and thereafter at least a linearly decreasing level [3]. Although this structure was designed essentially around the CLIC parameters, a parallel aim of the work was to investigate the general potential of the DDS for use with other 30 GHz linac parameters.

## 2 STRUCTURE GEOMETRY

The basic 30 GHz cell/manifold configuration is the same as that of the X-band DDS (Figure 1). Two cells at both ends of the structure are not coupled to the manifold to allow space for the output manifold bends. All cell and manifold dimensions are approximately scaled 11 GHz values except the minimum iris thickness which was limited to 0.5 mm to have sufficient mechanical stiffness, and the minimum iris diameter which was limited to 3.4 mm to avoid an excessive short range transverse wakefield level. The number of cells for this DDS design has been reduced to 100 cells from the 200 of the X-band structure. This was done to maintain a near optimum RF to beam efficiency for CLIC multibunch parameters and to restrict the maximum accelerating gradient to less than about 150 MV/m (corresponding surface field of about 400 MV/m).

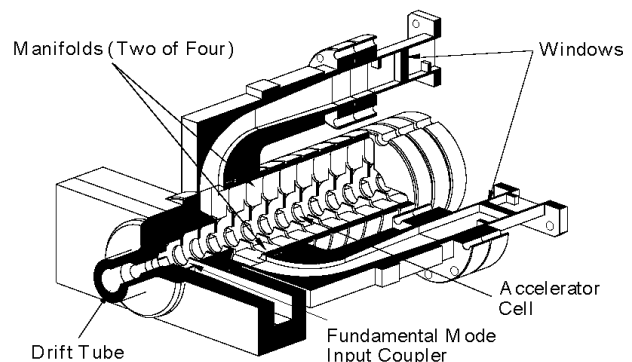

Figure: 1 The basic DDS configuration

## 3 MICROWAVE DESIGN AND ANALYSIS

The basic design approach is to add a light amount of damping to a detuned structure by coupling the cells to four parallel waveguide manifolds. The three stages of the rf design procedure are (i) analysis of the lowest dipole mode behaviour using an uncoupled cell model (all higher dipole modes are assumed to be detuned by an iris thickness variation) (ii) analysis of the behaviour of the two lowest dipole bands using a coupled cell two-band model (iii) spectral function analysis of the

detuned structure with manifold coupling. Details are given in references [4,5,6].

The maximum iris diameter was limited to 4.7 mm to obtain a small separation (150 MHz) between the first dipole pass band and the operating frequency. This results in a total detuning bandwidth for uncoupled cells of 8.4% (3.2 GHz). The truncated gaussian detuning distribution was chosen to have a  $\sigma = 1.56\%$  (0.6 GHz) to give a roll-off level of about 1% after a time of 30 fundamental RF cycles (the CLIC bunch spacing), and a minimum long range transverse wakefield level (the X-band DDS was optimised for a 16 RF cycle roll-off time).

In the coupled cell analysis it was found that modes with relatively high kick factors were concentrated in the last two cells which were not coupled to the manifold and were therefore not damped (Figure 2). This occurred because a relatively large minimum iris diameter was chosen to minimise the single bunch wake, and consequently the position where the fundamental dipole band changed from a forward wave to a backward wave, with the group velocity going through zero, was close to the end of the structure (in cell 99 of 101 cells). By using a sine-like (0-90°) iris thickness to diameter dependency rather than a linear one, these high kick modes are spread out and extend into damped cells.

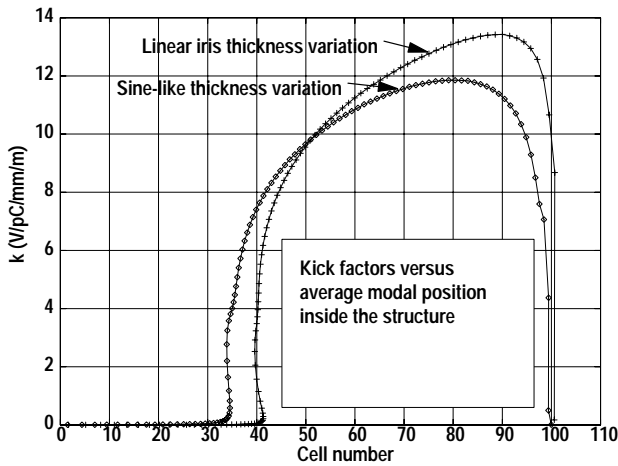

Figure: 2 Kick factors as a function of cell number

One of the main design aims is to maximise the time before recoherence occurs, this is proportional to the inverse frequency separation of the modes. The largest separation, and therefore the shortest time, occurs in the high frequency tail of the gaussian distribution where the previously mentioned undamped high kick modes are localised. Using a sine-like iris thickness distribution rather than a linear one increased the recoherence time significantly (see Figures 3 and 4). After the initial roll-off, the wakefield level for this purely detuned structure stays well above

10 V/pC/mm/m, which is unacceptable for the CLIC parameters [3]. The coupled cell  $kdn/df$  (kick factor  $\times$  modal density) distribution is shown in Figure 3. Although the coupled cell detuning bandwidth is larger than the uncoupled one, the  $\sigma$  is smaller resulting in a longer roll-off time (see Figure 5).

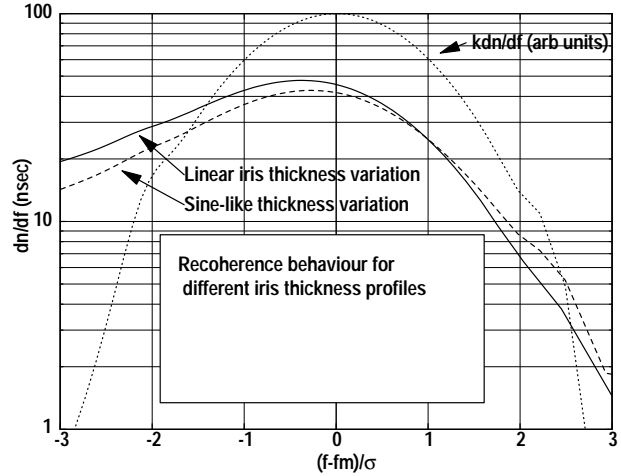

Figure: 3 The modal contributions to the wake

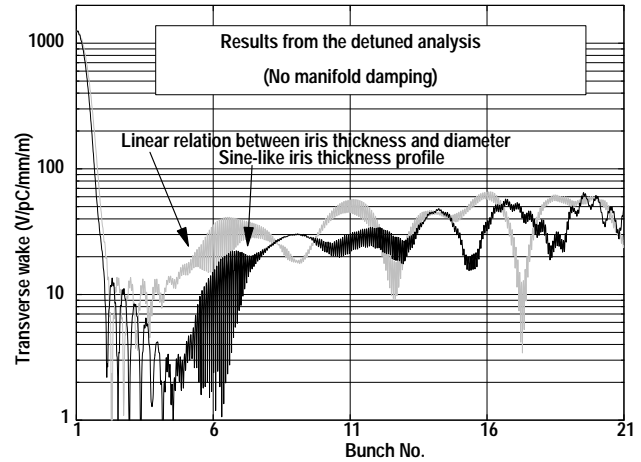

Figure: 4 The transverse wakefield calculated using a double band model but without damping manifold

As in the X-band structure, the dimensions of the damping manifold and the distance between manifold and cell (coupling strength) vary along the length of the structure. The main structure dimensions taking into account the cell/manifold coupling are given in Table 1.

Table 1 Main structure dimensions (input - output)

Cell diameter	8.68 - 8.12 mm
Iris diameter	4.66 - 3.40 mm
Iris thickness	0.50 - 1.10 mm
Manifold height	2.0 mm
Manifold width	4.38 - 4.21 mm
Manifold / cell spacing	+0.09 to -1.10 mm

Including the effect of the damping manifold using the spectral function method of analysis [6] modifies the  $kdn/df$  distribution. The effect of the damping manifold is to give a finite Q to the modes (previously assumed to be delta functions) causing them to overlap and produce a continuous but rippled spectral function - see Figure 5.

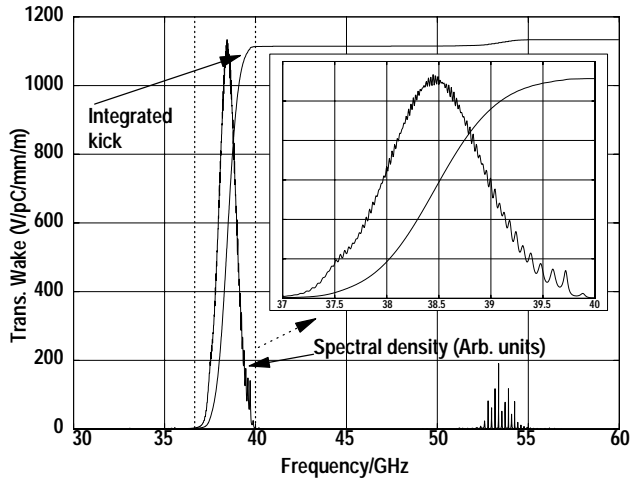

Figure: 5 Spectral function for cell/manifold coupled structure

The resulting transverse wake function is given in Figure 6. The long-range wake level is just below 10 V/pC/mm/m. The 40 V/pC/mm/m wake at the second bunch (1ns) is somewhat higher than that required for CLIC. This level can almost certainly be reduced by redesigning the structure to have a larger  $\sigma$  for the frequency distribution although this would probably increase the long range wakefield level. Increasing the number of cells to 150 would certainly improve the long range transverse wakefield performance. The manifolds are assumed to be perfectly terminated, however analyses made on the X-band structure have shown that the wake is seriously degraded by small termination mismatches.

Table: 2 The theoretical fundamental mode characteristics (input - output)

< Quality factor Q >	3900
Q	4450 - 3700
< Shunt impedance R / Q >	25 k $\Omega$ /m
R/Q	21.8 - 28.3 k $\Omega$ /m
< Group velocity $v_g / c$ >	7 %
$v_g / c$	13.3 - 3.6 %
Number of cells	101
Fill time	18 ns

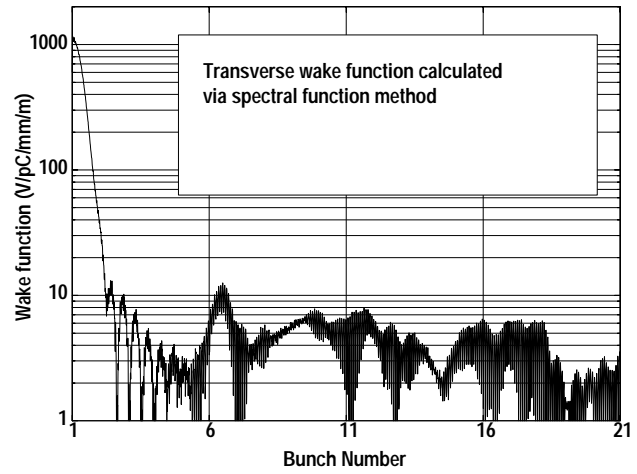

Figure: 6 The final 30 GHz DDS transverse wakefield

The steady state beam loaded voltage along the length of the DDS structure is shown in Figure 7.

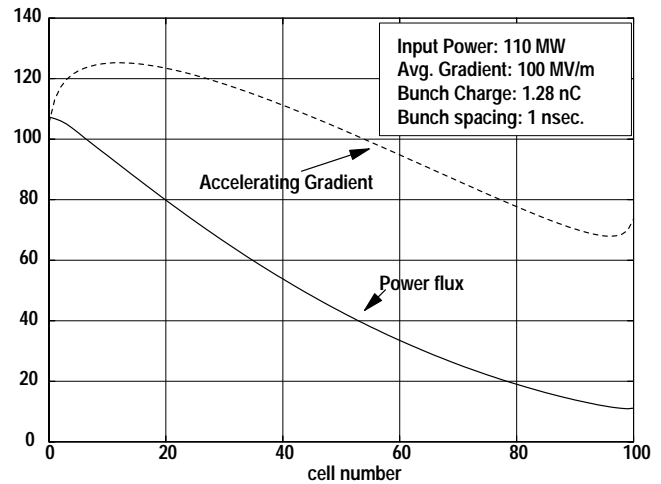

Figure: 7 The steady state beam loaded voltage

## REFERENCES

- [1] H.Braun and 10 co-authors: 'CLIC-A Compact and Efficient High Energy Linear Collider', PAC95, Dallas, May 1995.
- [2] J.P. Delahaye and 6 co-authors: 'A 30 GHz 5-TeV Linear Collider', these proceedings.
- [3] G.Guignard, J.Hagel: 'Beam characteristics versus Cavity Models in CLIC', these proceedings.
- [4] R.H. Miller and 20 co-authors: 'A Damped Detuned Structure for the Next Linear Collider', Proc. Linac96, Geneva, 1996.
- [5] K. Bane, R. Gluckstern, 'The Transverse Wakefield of a Detuned X-band Accelerator Structure', Particle Accelerators, Vol. 42, p 213 (1993).
- [6] R.M. Jones, K. Ko, N.M. Kroll and R.H. Miller: 'A Spectral Function Method Applied to the Calculation of the Wake Function for the NLCTA', Proc. Linac96, Geneva, 1996.