

HIGHER LUMINOSITY B-FACTORIES*

J. T. Seeman**, SLAC, Stanford, CA 94039, USA

Abstract

The present B-factories PEP-II and KEKB have reached luminosities of $3\text{-}4 \times 10^{33}/\text{cm}^2/\text{s}$ and delivered integrated luminosity at rates in excess of 4fb^{-1} per month [1,2]. The recent turn on of these two B-Factories has shown that modern accelerator physics, design, and engineering can produce colliders that rapidly reach their design luminosities and deliver integrated luminosities capable of frontier particle physics discoveries. PEP-II and KEK-B with ongoing upgrade programs should reach luminosities of over $10^{34}/\text{cm}^2/\text{s}$ in a few years and with more aggressive improvements may reach luminosities of order $10^{35}/\text{cm}^2/\text{s}$ by the end of the decade.

However, due to particle physics requirements, the next generation B-Facility may require significantly more luminosity. Initial parameters of a very high luminosity e^+e^- B-Facility or Super B-Facility (SBF) are being developed incorporating several new ideas from the successful operation of the present generation e^+e^- accelerators [3,4]. A luminosity approaching $10^{36} \text{ cm}^{-2}\text{s}^{-1}$ appears possible. Furthermore, the ratio of average to peak luminosity may be increased by 30% due to continuous injection. The operation of this accelerator will be qualitatively different from present e^+e^- colliders due to this continuous injection.

1 DESIGN DIRECTIONS

The accelerator community has learned a lot from the operation of the present B-Factories. High power RF systems do perform reliably. Ampere level beams can be stored stably. Bunch-by-bunch feedback systems work well at 2 to 4 nsec bunch separations. The fast ion instability for the electron beam is not a problem for these factories. The electron cloud instability is worse than expected. This is due to both short and long-range wakefields. Energy transparency conditions for the beam-beam effect are much weaker than they could have been. Large crossing angles seem to work acceptably. High-energy physics detectors can handle the increased backgrounds. Finally, the beam lifetimes are acceptable.

The next generation e^+e^- B-Facility will likely operate at the Upsilon (4S) with a center of mass energy of 10.58 GeV and with the same energy asymmetry as present. For the study here the PEP-II tunnel geometry was used as well as the PEP-II beam energies of 9.0 and 3.1 GeV. The choice of energy asymmetry is, at this time, an open question as a larger energy asymmetry makes the

beam separation at the interaction region easier but makes the RF costs larger. To increase the luminosity about two orders of magnitude the beam currents must be raised an order of magnitude and the beam cross sectional area reduced an order of magnitude while keeping the beam-beam tune shifts under control. The design below attempts to balance these various effects. The parameters below are self-consistent but further overall optimization can be made.

2 LUMINOSITY AND INTEGRATED LUMINOSITY

The luminosity can be calculated in several ways [5]. A convenient scaling formula for the luminosity L is shown in Eqn. 1. E is the beam energy (GeV), r the y/x size aspect ratio, ξ_y the vertical tune shift limit, I the beam current (A), and β_y the vertical beta function at the IP. Note that the tune shift ξ_y and the current I are not independent. Also, the number of bunches is a variable.

$$L = 2.17 \times 10^{34} (1+r) \xi_y \frac{EI}{\beta_y} [\text{cm}^{-2}\text{s}^{-1}] \quad (1)$$

In order to get a luminosity near $10^{36}/\text{cm}^2/\text{s}$ for the Low Energy Ring (LER) at 3.1 GeV, the following approximate parameter values are needed: $\beta_{x,y} = 0.33 \text{ cm}$, $\xi_y = 0.14$, $r = 1.0$ and $I = 20 \text{ A}$. For the High Energy Ring (HER) at 9 GeV, $\beta_{x,y} = 0.33 \text{ cm}$, $\xi_y = 0.14$, $r = 1.0$ and $I = 6.5 \text{ A}$.

The integrated luminosity will also increase by a separate factor of about 1.33 as this collider will need continuous injection making the average to peak luminosity about 0.95 as opposed to the present colliders which have ratios of about 0.7.

3 OVERALL DESIGN PARAMETERS AND CONSTRAINTS

The general overall parameters in Section 2 were used to make an accelerator design. The detailed parameters are shown in Table 1. The design choices and constraints are many. The two beam energies force two separate rings. There is one collision point. The circumferences are equal due to beam-beam interaction reasons. Round beams will be used to increase the beam-beam tune shifts. However, flat beams have traditionally worked well but may reduce the peak luminosity by a third for the same currents. Several RF frequencies are possible but 476 MHz was selected as that is the present PEP-II frequency. The number of RF cavities must be increased with the beam current. Every RF bucket has a bunch.

*Work supported by US Department of Energy contract DE-AC03-76SF00515.

**SEEMAN@SLAC.STANFORD>EDU

The interaction region is similar to that of PEP-II but must be longitudinally shortened to keep the peak betas in the interaction region quadrupoles as low as possible. Since the bunches are significantly shorter, a crossing angle can be used at the collision point to help separate the beams.

The beam lifetimes will be low forcing injection to be continuous. Continuous injection will also allow the beam-beam tune shift limits to be increased. Constant injection will allow the operators to very finely tune the collider to extract the most luminosity without fear of losing a stored beam, as in a traditional collider.

The HER will store positrons to reduce the effects of the electron cloud instability. The very high electron current in the LER will likely remove all collected ions. If not, clearing electrodes may have to be installed. The vacuum chambers may be a continuous extrusion, welded together to minimize impedance issues and reduce the number of fragile vacuum elements such as bellows.

The present magnetic lattice for the LER is adequate but the magnet lattice for the HER ring must be modified for a lower momentum compaction factor to reduce the bunch length. This can be accomplished by increasing the phase advance per cell, combined function magnets, or additional quadrupoles.

Table 1. Initial parameters for a 10^{36} B-Factory

Accelerator Parameter	HER	LER
Beam energy (GeV)	9.0	3.1
Beam particle	e+	e-
Center of mass energy (GeV)	10.58	10.58
Circumference (m)	2200	2200
RF frequency (MHz)	476	476
RF voltage (MV)	50	30
Number of bunches	3492	3492
Total beam current (A)	6.6	19.2
Beta* (y/x) (cm)	0.32/0.32	0.32/0.32
Emittance (x/y) (nm)	22/22	22/22
IP beam sizes x and y (μm)	8.5	8.5
Momentum compaction	0.001	0.0013
Bunch length (mm)	3.5	3.5
Approx. AC power (MW)	50	27
Beam lifetime (min)	4.4	4.6
Injection particle per pulse	7.3E10	5.3E10
Injection rate (Hz)	20	80
Beam-beam tune shifts	0.14	0.14
Luminosity ($/\text{cm}^2/\text{s}$)	10^{36}	10^{36}

4 BEAM-BEAM TUNE SHIFTS

The observed beam-beam tune shifts in PEP-II are approaching 0.07 [2]. The expected tune shifts in this new accelerator should be larger for two reasons. Theoretical and experimental evidence indicates that round beam

operation of the collision point will increase the tune shifts by about a factor of two. However, there may be increased backgrounds from round beam operation but significantly more backgrounds are expected from other sources as well. Furthermore, it has been observed in PEP-II during routine running that by adjusting the tunes the luminosity can be increased significantly (~10%) at the expense of the beam lifetime [6]. This beam lifetime will be called the beam-beam lifetime. A higher luminosity for the same current means higher tune shifts. It is believed that this new accelerator can take advantage of continuous injection to push the tune shifts to significantly higher values and consequently the beam-beam lifetimes to significantly lower values. The beam-beam lifetime in present colliders is about 100 minutes. The assumption used in this note is that the tune shifts can be increased from 0.07 to 0.14 by reducing the beam-beam lifetime from 100 minutes to 10 minutes and by adopting round beams at the collision point.

5 INTERACTION REGION

The interaction region will likely have a similar geometry to that of PEP-II [7]. The cone angle separating the accelerator and detector components can be the same at about 300 mrad. The focusing quadrupoles must be as close to the interaction point (IP) as possible to reduce the peak beta functions in those quadrupoles. The LER quadrupoles for this accelerator can be moved significantly closer to the IP than in PEP-II using superconducting Q1 and Q2 magnets with stronger gradients. A good choice for these magnets are those used in the HERA upgrade [8]. The HER quadrupoles can also be moved closer because the LER quadrupoles have been moved. A crossing angle of about +/- 2 mrad is used to help separate the beams at the first parasitic beam-beam crossing. The beams are horizontally separated by about $12 \sigma_x$ at the first parasitic crossing.

6 RF SYSTEM AND BEAM POWER

The RF system design can be similar to that of KEKB or PEP-II but with an order of magnitude larger scale. The basic parameters are shown in Table 2. The longitudinal beam dynamics will be difficult with the large beam currents. To keep the beams stable, it is likely that the solutions used for KEKB (storage cavities) and for PEP-II (strong bunch-by-bunch feedbacks) will both be needed.

Table 2 RF and Beam Power Parameters for a SBF.

RF Parameter	HER	LER
RF frequency (MHz)	476	476
Number of klystrons	30	20
Number of cavities	70	40
Total RF voltage (MV)	50	30
Beam current (A)	6.6	19.2
Sync. Rad. Power (MW)	23	12
Bunch length (mm)	3.5	3.5

7 VACUUM SYSTEM

The HER vacuum system must dissipate over 16 kW/m of synchrotron radiation power. The chambers will likely be made with an antechamber with a continuous built-in photon stop. A concept of the aluminum chamber is shown in Figure 1. The design of the bellow (expansion) modules will be very difficult for these high currents and short bunch lengths. Instead, the plan is to use a concept investigated for the PEP-II rings but not implemented. The vacuum system would be a continuous extrusion welded together with no bellows but with rigid supports to constrain thermal stresses [9]. A similar technique is used to build very long train rails. Moreover, the beam impedance will be better without bellows. The stainless steel chambers in the straight sections will need to be changed to a lower resistance material to reduce the resistive wall effect for the LER.

8 BEAM LIFETIME

The beam lifetime has several components. The five main contributors are discussed here. A summary is shown in Table 3 giving a total beam lifetime of about 4 to 5 minutes for each beam, hence the need for continuous injection.

1) Luminosity lifetime comes from particle losses from collisions. The loss rate is given by

$$\frac{dN}{dt}(t) = -\sigma L(t) \quad (2)$$

where N is the total number of particle in the beam. σ is cross section for a scattered particle to leave the accelerator aperture. σ is about $3 \times 10^{-25} \text{ cm}^2$. At $L = 10^{36}$, $dN/dt = 3 \times 10^{11}$ per second.

2) The vacuum lifetime comes from beam-gas scattering. The vacuum pressure will likely be somewhat worse than PEP-II as there is more synchrotron radiation. Vacuum lifetimes one-third those of PEP-II are used.

3) The Touschek lifetime comes from intra-bunch particle scattering. The approximate Touschek lifetimes in PEP-II are 3 hours for the LER and 30 hours for the HER. The lifetime for this collider can be scaled from these values. For this accelerator the bunch charges are higher than for PEP-II reducing the lifetime about a factor of two. The transverse sizes are larger than PEP-II due to round beams, thus, increasing the lifetime about a factor of two. However, the longitudinal size is three times smaller which will reduce the Touschek lifetime by a factor of three. Overall change is about a factor of three reduction.

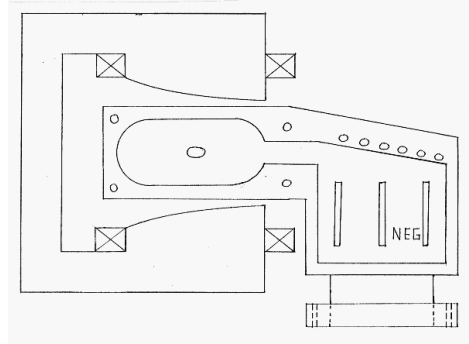

Figure 1 Possible magnet and vacuum chamber for the HER of a SBF.

4) The beam lifetime from the beam-beam interaction will be reduced to about 10 minutes to maximize the beam-beam tune shifts.

5) The beta functions in the interaction region quadrupoles are larger than those in PEP-II and will likely lead to reduced beam lifetime from a reduced dynamic aperture as determined from chromatic sextupole corrections. A lifetime from this effect is hard to predict but 20 minutes is used.

Table 3 Beam Lifetime Contributions

Lifetime Contribution	HER	LER
Luminosity lifetime (min)	15	58
Vacuum lifetime (min)	100	30
Touschek lifetime (min)	600	60
Beam-beam tune shift lifetime (min)	10	10
Dynamic aperture lifetime (min)	20	20
Overall lifetime (min)	4.4	4.6

9 INJECTION

Injection must be a continuous process because the beam lifetimes are short. Taking the SLAC site, the beams would come from the damping ring and linac complex. The parameters for this system are shown in Table 4. The SLAC system was built to provide about 1×10^{11} electrons per pulse at 120 Hz and about half that rate for positrons. The RF frequency of the damping ring cavity would be changed from 714 MHz to 476 MHz.

In the damping rings, the particle bunches will be distributed uniformly over about half of the 35 m circumference in about 30 bunches. The other half of the ring circumference is used by the injection and extraction kicker rise times.

The linac can operate at 120 Hz. The electron injection rate would likely be 80 Hz, the positron injection

rate 20 Hz, and the remaining 20 Hz used for positron production.

Injection losses can cause detector problems. However, the damped injected beam will have transverse emittances smaller than the stored beam emittances. Also, the linac bunch length and energy spread match well those of the stored bunches. Thus, the injection process should be relatively clean. However, as some injection collimation will likely be needed, the injection efficiencies were taken to be 75%.

Table 4. SBF Injection Parameters

Injection Parameter	HER	LER
Number of particles	3.0E14	8.8E14
Particle type	e+	e-
Injection energy (GeV)	9.0	3.1
Beam lifetime (min)	4.4	4.6
Ring particle lost per second	1.1E12	3.2E12
Injection rate (Hz)	20	80
Injection efficiency	0.75	0.75
Injected particles per pulse	7.3E10	5.3E10
Bunches inject per pulse	30	30
Inject particles per bunch	1.8E9	1.3E9
DR RF frequency (MHz)	476	476

10 FUTURE STUDIES

Many studies must be done to bring these ideas closer to a practical accelerator. Listed here are a few of the more important topics. 1) The effects of the short beam lifetime and continuous injection on the physics detector. 2) The interaction region layout with round beams, higher detector fields, and smaller IP chamber. 3) The

longitudinal beam stability at high currents. 4) The parameters of the bunch-by-bunch feedbacks. 5) The beam-beam interaction allowing a higher beam-beam tune shift but with a shorter beam lifetime.

11 ACKNOWLEDGMENTS

The author wishes to thank J. Dorfan, S. Henderson, S. Kurokawa, D. Rice, D. Rubin, H. Schwarz, A. J. S. Smith, M. Sullivan, U. Wienands, and F. Willeke for discussions concerning various limitations of colliding beams. This work was supported by US Department of Energy contract DE-AC03-76SF00515.

12 REFERENCES

- [1] Y. Funakoshi et al., "KEKB Performance," EPAC 2000, p. 28.
- [2] J. Seeman et al., "Status Report on PEP-II Performance," EPAC 2000, p. 38 and Proceedings of PAC2001.
- [3] J. Seeman, "Initial Parameters for a $10^{36}/\text{cm}^2/\text{s}$ Luminosity e^+e^- B-Factory," SLAC-PUB-8787, March 2001.
- [4] D. Rice, "e+e- Factories- The Next Generation," HEACC 2001, Tsukuba, Japan, March 2001.
- [5] M. Furman, M. Zisman, "Luminosity," Handbook of Accelerator Physics and Engineering, World Scientific, A. Chao, M. Tigner, eds., p. 247 (1999).
- [6] M. Sullivan, U. Wienands, private communication.
- [7] "PEP-II Conceptual Design Report," SLAC Report 418, June 1993.
- [8] B. Parker et al., "Superconducting Magnets for use inside the HERA ep Interaction Regions," PAC1999 p. 308.
- [9] L. Klaisner, private communication.