

CALT-68-2193
SLAC-PUB-7951
September 1998

Status of the BaBar Detector*

F. C. Porter

For the BaBar Collaboration

Physics Department, Caltech, Pasadena, CA 91125
Stanford Linear Accelerator Center, Stanford University, Stanford, CA 94309

To be published in the
Proceedings of the 29th International Conference on High Energy Physics
Vancouver, Canada, July 23-29, 1998

*Work supported in part by Department of Energy grant DE-FG03-92ER40701 and contract DE-AC03-76SF00515.

STATUS OF THE BABAR DETECTOR

F. C. PORTER

Physics Department, Caltech, Pasadena, CA 91125, USA

E-mail: fcp@hep.caltech.edu

FOR THE BABAR COLLABORATION

The BaBar experiment, under construction at the PEP-II e^+e^- colliding beam storage ring, is motivated by the desire to study rare B decays, and especially CP violation in the B system. The requirements for, design, and status of the construction of the various detector systems are summarized. Much of the construction is complete, and BaBar has entered the installation and check-out phase. Problems with potential schedule impact have been aggressively addressed, and it is planned to complete construction and roll onto the beam line in time for the start of physics collisions in April 1999, as originally scheduled.

1 Introduction

The B meson is especially interesting because of its long lifetime, which means that standard model processes are sufficiently suppressed that mechanisms beyond the standard model may be observable. An area of particular importance is the study of CP violation via the large observed mixing in the B^0 system. To study CP violation via mixing in $B^0\bar{B}^0$ produced at the $\Upsilon(4S)$ in e^+e^- collisions, a center-of-mass which is moving in the laboratory is required, in order that the time evolution of the $B^0 - \bar{B}^0$ decays can be measured. With this approach, an error on, for example, $\sin 2\beta$ of order 0.12 in the $J/\psi(\ell^+\ell^-)K_S(\pi^+\pi^-)$ mode, and 0.076 averaged over several modes, is expected for a 30 fb^{-1} dataset. The PEP-II accelerator¹ at SLAC is a new asymmetric storage ring collider for this purpose, and the BaBar detector² is under construction to take data on collisions at PEP-II.

The BaBar collaboration consists of approximately 600 physicists and engineers from 72 institutions in 9 countries (Canada, China, France, Germany, Italy, Norway, Russia, United Kingdom, and USA). Despite the wide geographical distribution, this has functioned remarkably well, with different countries contributing major portions of the detector.

2 PEP-II

The PEP-II accelerator is designed to produce e^+e^- collisions at center of mass energies in the Υ region, with a moving center of mass, $\beta\gamma = 0.56$ at the $\Upsilon(4S)$. The design luminosity is $\mathcal{L} = 3 \times 10^{33} \text{ cm}^{-2}\text{s}^{-1}$. The storage ring consists of two rings, a "high energy ring" (HER), carrying electrons at approximately 9 GeV, located below a "low energy ring" (LER), carrying positrons at about 3.1 GeV. Collisions are head-on, with trajectories separated magnetically as the beams emerge from the interaction point (IP). The bunch collision frequency is 238 MHz.

Table 1: PEP-II Parameters.

Parameter	HER	LER	Units
Energy	9	3.1	GeV
I	0.75	2.14	A
# bunches	1658	1658	
σ_x^*	155	155	μm
σ_y^*	4.7	4.7	μm
σ_z^*	1.0	1.0	cm
σ_{ECM}	5.2		MeV
$\mathcal{L}_{\text{peak}}$	3×10^{33}		$\text{cm}^{-2}\text{s}^{-1}$

Table 1 summarizes some of the interesting accelerator parameters.

PEP-II construction is essentially complete, and the accelerator is being commissioned. The HER commissioning began in May 1997. It has performed well, and has met already several of the key design goals, such as bunch current, lifetime, and number of bunches. The LER commissioning began in July 1998, and first collisions were observed, in beam-beam disruption, and in tune crosstalk, also in July 1998. Further commissioning will take place in Fall 1998, prior to disassembly of the interaction region in January 1999 for detector roll-on.

3 Detector Requirements

- Vertex resolution: Good vertex resolution is crucial for the CP -violation studies, because of the requirement to measure the decay time difference between the two B^0 decays. The scale of the requirement is set by the B average flight path of $\sim 260 \mu\text{m}$ at the PEP-II asymmetry. BaBar is designed to have an impact parameter resolution of

$$\sigma_z = \sigma_{xy} = [50/p_t(\text{GeV}) \oplus 15] \mu\text{m},$$

where the \oplus denotes quadratic combination.

- Tracking resolution: Good tracking resolution is important for reconstruction of the final decay states, in order to suppress backgrounds. BaBar is designed to have a track momentum resolution of

$$\sigma_{p_t}/p_t = [0.21 + 0.14p_t(\text{GeV})] \%,$$

for $p_t > 200 \text{ MeV}$, in the drift chamber.

- Photon detection and measurement: A substantial fraction of the decays of the particles of interest contain π^0 's or other neutral particles. Thus, photon measurement is important in the reconstruction of many exclusive states. The BaBar calorimeter is designed to have a photon energy resolution of

$$\sigma_E/E = [1/E(\text{GeV})^{\frac{1}{4}} \oplus 1.2] \%,$$

and an angular resolution of

$$\sigma_\theta = [3/\sqrt{E(\text{GeV})} \oplus 2] \text{ mr.}$$

- Particle identification: A key part of the anticipated CP violation measurements involves the tagging of the B^0 flavor (*i.e.*, B or \bar{B}), using both leptons and kaons. Pion-kaon separation is also important in distinguishing exclusive modes such as $B \rightarrow \pi\pi$ from $B \rightarrow K\pi$, for which kinematic separation is marginal. Particle identification up to about 4 GeV momentum is required, and BaBar is designed to achieve this, using dE/dx , Cerenkov, and calorimetric measurements.
- Hermeticity: Large solid angle coverage is of course important for efficiently reconstructing multi-particle final states. It is also important in studies which require measuring the “missing” momentum, *e.g.*, reconstructing the neutrino in $B \rightarrow \ell\nu$ decays. The instrumented flux return (IfR) serves the dual roles of muon identifier and hadron calorimeter, in particular for K_L^0 and other neutral hadrons.
- The detector and computing must be able to handle a trigger rate to tape of order 100 Hz, of which approximately 10 Hz is single-photon hadronic triggers. The event reconstruction should be nearly real time, to provide rapid data quality feedback, and timely physics analysis. The simulation tools must contain sufficient detail and quality to model efficiencies and backgrounds in large datasets.

4 Status of Detector Systems

The overall BaBar detector is of a by-now standard large solid angle solenoidal design. The various elements are

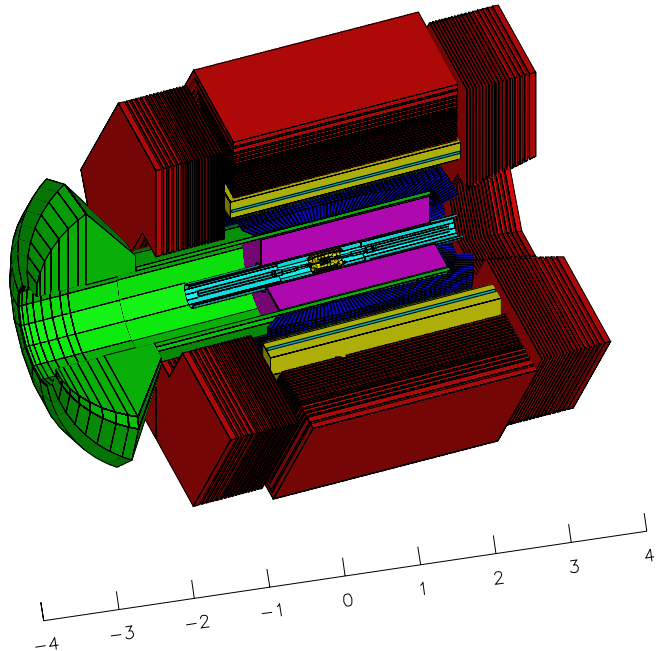

Figure 1: Cut-away view of the BaBar detector, as seen by the simulation program. The scale is in meters. At smallest radii are the PEP-II beam components and silicon vertex tracker, followed by the drift chamber and the DIRC quartz bars. Outside the DIRC is the CsI calorimeter, followed by cylindrical RPCs, the solenoid coil, and the instrumented flux return. The large object at the left is the water stand-off box for the DIRC.

illustrated in Figure 1. Note that the detector is somewhat asymmetric, to match the asymmetry in the beam energies.

4.1 Silicon Vertex Tracker

The silicon vertex tracker (Svt) consists of five layers of double-sided silicon strip tracking, fabricated on $300\mu\text{m}$ silicon, with strip readout pitch ranging from 50 to 210 microns. The radii of the layers range from 3.3 cm to 14.4 cm, and cover polar angles between 17.2 and 150 degrees. The provision of five layers permits this to be used as an independent tracker, besides providing for precision vertex measurement. This helps, for example, in the detection of the slow pion from $D^* \rightarrow D$ decays. The digitization uses a time-over-threshold custom integrated circuit, the “AToM” chip (for “A Time-over-threshold Machine”),³ with 128 channels, sparsification, and serial readout.

The support structure for the Svt, a low-mass carbon fiber structure which mounts on the permanent magnet bends near the IP, is complete. The silicon strip wafers are all in hand, and have been tested to be of good quality in terms of pinholes and leakage. Wirebonding (570k

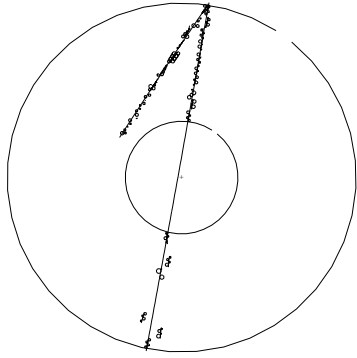

Figure 2: View of a cosmic ray from commissioning of the BaBar drift chamber. Approximately 50% of the chamber is instrumented; the gaps in the lower track and the termination in the track away from the IP are due to uninstrumented regions. The stereo hits are plotted at wire center, hence deviations from the fitted tracks indicate z position. The tracks are drawn as reconstructed by the reconstruction software – the track through the IP is actually reconstructed as two tracks.

bonds) is in production. Single module tests have been performed in a CERN test beam, and in conjunction with the PEP-II commissioning. There have been some difficulties with the front end readout electronics (AToM IC and high density interconnect hybrid) which have taken up available float in the schedule, although the Svt installation is still scheduled for January 1999.

4.2 Drift Chamber

The drift chamber (Dch)⁴ is a 40-layer hexagonal-cell device with cell diameters of approximately 1.5 cm, 276 cm in length, and occupying radii between 23.6 and 81 cm. The layers are arranged in axial-U-V (40–70 mrad) superlayers of 4 layers each. A low-Z gas consisting of 80% helium and 20% isobutane is used. The readout of the 7104 sense wires provides both time and amplitude, giving dE/dx information for particle identification. The $B^0 \rightarrow \pi^+ \pi^-$ mass resolution is expected to be 20-23 MeV over 80% of 4π . A capacitive system is used to monitor the relative positions of the Svt and the final bend magnets, and of the Dch and the support tube containing the Svt and bends.

Tests of a full-length prototype give resolution in agreement with design, with better than $100 \mu\text{m}$ at the minimum, $130 \mu\text{m}$ averaged over a cell, and dE/dx resolution extrapolating to 6.8% for the full 40-layer Dch. The chamber stringing is complete, and it is currently being commissioned with cosmic rays. Figure 2 shows a cosmic ray track observed in the drift chamber, prior to installation in the solenoid scheduled for late August. The gas system is under construction at the interaction region.

4.3 Cerenkov Particle Identification System

The particle identification system is a novel Cerenkov ring imaging device called a “DIRC”, for “Direct Imaging Ring Cerenkov”. Quartz bars serve as the Cerenkov radiator, and also as light guides which carry the ring image out the ends of the bars via total internal reflection. At the end of the quartz bar, the light exits into a large water volume, providing a lever arm of about 1.2 meter before the ring is detected by a dense array of 10,752 photomultipliers. Each of the 144 quartz bars is 4.9 m long, constructed by gluing 4 shorter bars together. The radial thickness of a bar is 1.7 cm. The DIRC system presents about 14% of a radiation length (at 90°) to particles before they reach the calorimeter, following slightly over 5% from the components at smaller radii, averaged over azimuth.

The water volume (“Stand-Off Box”, or SOB) and photomultiplier array are complete. A substantial prototype test⁵ was made in a CERN test beam, and the pattern recognition software is well-advanced. The quartz bars are in production, although the vendor has been having difficulties leading to delay. The installation schedule is being kept flexible in order to accommodate the delays without incurring a delay in the final detector readiness. The most critical aspect is that a third of the bars must be installed before the detector rolls onto the beam-line.

4.4 Electromagnetic Calorimeter

As good photon energy resolution is important, the electromagnetic calorimeter (Emc) consists of an array of CsI(Tl) crystals, 5760 in the barrel arranged in 48 z slices of 120 crystals, and 820 in the forward calorimeter arranged in 8 rings of 80-120 crystals. Each crystal is observed by two photodiodes, with two detector-mounted amplifier ICs, for redundancy. Crystals are supported in carbon fiber compartments, and mounted from the rear, in the barrel, to a cylindrical aluminum strongback in groups of 3×7 crystals. The crystals range from approximately 16 to $17.5 X_0$, with the longer lengths concentrated in the forward region in the lab frame. A relatively high energy radioactive calibration source is generated via neutron activation of a fluorine-based liquid (3M Fluorinert FC-77), eventually yielding a 6.13 MeV line in $^{16}\text{O}^*$ decays. When a calibration is desired, the activated fluid is pumped through panels on the inner surface of the calorimeter. The design is for a statistical uncertainty in a crystal of 0.25%, in a 15 minute calibration.

A 25 crystal prototype calorimeter array was tested in a beam at PSI⁶ The barrel calorimeter is complete, and was installed in the solenoid on July 10, 1998. All channels have been determined to be functional via

pulsar and ^{228}Th (2.6 MeV γ) tests. The alignment of the barrel calorimeter has been completed. The source calibration panels are installed in the barrel. All but 25 of the forward calorimeter crystals are in hand, with the final delivery due mid-August.

4.5 Solenoid Magnet

A 1.5 Tesla superconducting solenoid provides the magnetic field for momentum analysis in the tracking volume. There is a bucking coil located where the DIRC bars exit the flux return, in order to reduce the field at the DIRC photomultipliers to an acceptable level.

The magnet is complete and installed in the flux return at the interaction hall. The net magnetic axial force has been determined to be acceptable and in approximate agreement with modeling. Magnetic mapping has been performed at both 1 and 1.5 T. The DIRC bucking coil is found to perform its design function, and the field strength at the final focus quadrupoles is acceptable.

4.6 Instrumented Flux Return

The instrumented flux return⁷ consists of 18-19 layers of resistive plate chambers (RPCs) interspersed with the iron of the flux return for the magnet. The thickness of the iron plates increases from 2 cm to 10 cm with distance from the IP. The total iron thickness is 65 cm in the barrel, and 60 cm in the endcaps. The RPCs consist of a 2 mm gap between 2 mm thick Bakelite plates, on the outer surface of which high resistivity graphite layers are painted. The graphite is followed by insulating PVC film, then aluminum strips to pick up induced signals for readout. The minimum muon momentum required to be detected in the Ifr is 500 MeV. In addition, there is a 2-layer (each with two views) cylindrical RPC between the Emc and the solenoid. There are approximately 50,000 strips in the Ifr.

The iron for the flux return is complete and installed. The RPCs are complete, and nearly all installed in the detector.

4.7 Electronics and Data Acquisition

In addition to the Svt chips, there are 6 custom integrated circuits in BaBar: (i) Dch amplifier/shaper/discriminator; (ii) Dch ELEFANT (for "ELEctronics For Amplitude 'N Timing") time/amplitude digitizer with 1 ns TDC binning and 15 MHz FADC sampling (6-bit resolution with an 8-bit range); (iii) DIRC amplifier/shaper/discriminator; (iv) DIRC time-to-digital and fifo IC; (v) The Emc preamplifier/shaper, mounted one/photodiode on the crystals; (vi) The CARE (for "Custom Auto-Range Encoding") amplifier and range-selecting chip for the

Emc. All of these chips are complete or in production. There are approximately 40 different circuit boards, nearly all complete or in production.

The data acquisition for the experiment proceeds from the front end digitization through VME single-board computer modules, called read-out modules (ROMs). These modules have a detector-specific "personality card" (in fact, there are only two varieties of this card for BaBar). Upon receipt of a level one trigger, the data is transferred to a commercial PowerPC-based single board computer (also part of the ROM) running the VxWorks operating system. From the approximately 150 ROMs, data is transferred over a switched 100 BaseT network to the online farm, consisting of Sun Ultra 60 computers. The events are assembled in this process, and the level three trigger (there is no "level two" trigger) is run on the farm, reducing a design level 1 trigger rate of 2 kHz to a level 3 tape rate of 100 Hz. The raw event size is anticipated to be slightly over 30 kbyte/event, including backgrounds. Detector control and monitoring is based on the EPICS toolkit.

The level 1 trigger makes decisions based on tracks in the drift chamber and energy clusters in the calorimeter. It must generate its own event time. The level 3 trigger has all of the event information available as required. The trigger is essentially fully efficient for $B\bar{B}$ events, with high efficiency for $\tau^+\tau^-$ events which can be traded off for background rejection if required by running conditions.

The basic data acquisition chain has been demonstrated in the drift chamber cosmic ray commissioning, though there is still much to do before the system will be ready for colliding beams, such as multicrate readout and partitioning of the detector permitting parallel independent readout chains. The installation of the first contingent of online farm CPUs will take place in August.

4.8 Offline Computing

The offline computing⁸ consists of several components, for event simulation, event reconstruction, physics analysis, data storage, *etc.* In the planning for the experiment, an object-oriented methodology, with implementation in C++, was adopted. Code management and distribution for the widespread development team is implemented in a software release tools package, based on CVS (Concurrent Versions System) and AFS (Andrew File System). Several Unix platforms (DEC/OSF, HP/UX, IBM/AIX, and Sun/Solaris) are currently supported, subject to ongoing evaluation.

The detector simulation currently is based on the Fortran GEANT3 package; however, we are in the midst of developing a GEANT4 (C++) implementation, and plan for this to serve both our fast- and detailed-

Table 2: Near-term BaBar Schedule.

Task	Date
Barrel calorimeter install in coil	Jul 1998
Drift chamber installation in coil	Aug 1998
Install DIRC SOB	Late Sep 1998
Install forward calorimeter	Oct 1998
Cosmic ray commiss. with magnet	Nov-Dec 1998
Break IR beamline for roll-on	Jan 1999
Install Svt	Jan 1999
Roll-on to beam line	Jan-Mar 1999
First colliding beam data	Apr 1999

simulation needs, starting at the end of 1998. The reconstruction code has essentially complete functionality, and is in the process of undergoing a second major round of testing under production conditions. For both the “conditions” (*e.g.*, detector configuration, calibration data) database and the event store, we are developing a solution based on the commercial Objectivity object oriented database management system. For the event store, this is being layered on the HPSS (High Performance Storage System, IBM) package to manage the underlying disk/tape files. The size of the overall event store is of order 100 Tbyte/year.

5 Schedule

Table 2 summarizes highlights of the remaining schedule for BaBar installation, commissioning, and roll-on, with colliding beam data to start in April 1999. The cosmic ray commissioning run at the end of 1998 will be with a complete detector, excepting the Svt, which will be installed in the coil in January, and the DIRC, which will not yet have its complete array of quartz bars.

6 Conclusion

The construction of BaBar has not been without its technical problems and delays. However, the collaboration has been very aggressive in dealing with issues in order to keep to a schedule in which colliding beam data begins in April of 1999. Much of the detector is complete, and we are in the installation and commissioning phase. Many activities remain to be finished, but we are so far on track for an April 1999 start. We are therefore actively planning for the “first year physics”.

Acknowledgements

Credit goes to the collaborators and collaborating institutions on BaBar. This work was supported in part by

the US Department of Energy under grant DE-FG03-92-ER40701 (Caltech) and contract DE-AC03-76-SF00515 (SLAC).

References

1. “An Asymmetric B Factory Based on PEP: Conceptual Design Report”, edited by M. Zisman, SLAC-372 (1991); updated as SLAC-418 (1993).
2. D. Boutigny *et al.*, Technical Design Report for the BaBar Detector, SLAC-R-95-457, March 1995; BaBar web pages at: <http://www.slac.stanford.edu/BFROOT/doc/www/bfHome.html>.
3. I. Kipnis *et al.*, *IEEE Trans. Nucl. Sci.* **44** (1997) 289.
4. G. Sciolla *et al.*, SLAC-PUB-7779, May 1998, Submitted to *Nucl. Instrum. Methods*.
5. H. Staengle *et al.*, *Nucl. Instrum. Methods A* **397** (1997) 261.
6. R. J. Barlow *et al.*, SLAC-PUB-7887, July 1998, Submitted to *Nucl. Instrum. Methods A*.
7. F. Anulli *et al.*, INFN-AE-97-30, July 1997, Submitted to *Nucl. Phys. Proc. Suppl.*
8. N. Geddes, *Comp. Phys. Comm.* **110** (1998) 38.