

SLAC-PUB-7759
March, 1998

Systematics of Slepton Production in e^+e^- and e^-e^- Collisions

MICHAEL E. PESKIN*
Stanford Linear Accelerator Center
Stanford University, Stanford, California 94309 USA

ABSTRACT

I present the basic formulae for slepton production in e^+e^- and e^-e^- collisions in an especially simple form, using a helicity basis. This parametrization introduces the useful *neutralino functions* to connect the neutralino eigenstates to observable cross sections.

to appear in the proceedings of the
Second International Workshop on Electron-Electron Interactions at TeV Energies
Santa Cruz, California, 22-24 September 1997

*Work supported by the Department of Energy, contract DE-AC03-76SF00515.

SYSTEMATICS OF SLEPTON PRODUCTION IN e^+e^- and e^-e^- COLLISIONS

MICHAEL E. PESKIN[†]
Stanford Linear Accelerator Center
Stanford University, Stanford, California 94309 USA

I present the basic formulae for slepton production in e^+e^- and e^-e^- collisions in an especially simple form, using a helicity basis. This parametrization introduces the useful *neutralino functions* to connect the neutralino eigenstates to observable cross sections.

1. Introduction

Today, it seems that supersymmetry is the extension of the Standard Model most likely to be observed at high energies. Thus, when we consider any future accelerator, it is important to pay attention to its capabilities for studies of supersymmetry. By this, I mean not only the first discovery of supersymmetric particles but also the systematic measurement of the mass spectrum of supersymmetric particles. If supersymmetry is indeed a property of Nature, the supersymmetry spectrum can be a window into physics at very small distances, perhaps even into the most fundamental interactions.^{1,2} To look through this window and see everything that it presents to us, we will need a variety of effective tools.

The e^-e^- collider can access supersymmetric particles through the reactions

$$e^-e^- \rightarrow \tilde{e}^-\tilde{e}^-, \quad (1)$$

with the partners of the left- and right-handed electron and positron in the final state. As long as the selectrons are light enough to be pair-produced, the cross sections for these processes are substantial, of the order of a unit of R . These processes lead to characteristic final states consisting of e^-e^- plus missing neutral particles.

Cuypers, van Oldenbourg, and Rückl³⁻⁵ have studied the observability of this signature in some detail. They have found that it is rather easy to detect even in the region of parameters $\mu \ll m_2$ which presents a special problem for supersymmetry searches. The irreducible Standard Model background $e^-e^- \rightarrow e^-e^-Z^0$ can be eliminated using the final state kinematics, and the other dominant background, from $e^-e^- \rightarrow e^-\nu W^-$, with the W^- decaying leptonically and one electron lost, can be controlled by kinematic cuts and the use of initial-state polarization. Thus, the reaction (1) could provide an especially clean sample of events for precision studies.

[†]Work supported by the Department of Energy, Contract DE-AC03-76SF00515.

The reactions (1) proceed by exchange of a neutralino. Thus, they potentially give information on the spectrum and mixing angles of the neutralinos. The information one obtains is similar to that provided by the reactions

$$e^+e^- \rightarrow \tilde{e}^+\tilde{e}^- . \quad (2)$$

Though these reactions can also involve s -channel annihilation through a photon or a Z^0 , typically the t -channel neutralino exchange diagrams are dominant.

To compare e^+e^- and e^-e^- reactions more carefully, it is useful to present the formulae for these cross sections as simply as possible. Of course, these cross sections are well known; they can be found, for example, in the compendium of Baer, Bartl, Karatas, Majerotto, and Tata,⁶ and some are even given in the famous review of Haber and Kane.⁷ The sensitivity of slepton production to the neutralino parameters have been studied in detailed simulations by the JLC group.^{8,9} Still, it never hurts to make the basic interrelations more transparent. That is the goal of this short paper.

2. Neutralino Mixing

To begin, let me review a bit of the formalism of neutralino mixing. The neutralino mass matrix, written in the basis of superpartners of the $U(1)$ and neutral $SU(2)$ gauge bosons and the Higgsinos $(\tilde{b}, \tilde{w}^3, \tilde{h}_1^0, \tilde{h}_2^0)$, takes the form

$$\mathbf{m} = \begin{pmatrix} m_1 & 0 & -m_Z s_w \cos \beta & m_Z s_w \sin \beta \\ 0 & m_2 & m_Z c_w \cos \beta & -m_Z c_w \sin \beta \\ -m_Z s_w \cos \beta & m_Z c_w \cos \beta & 0 & -\mu \\ m_Z s_w \sin \beta & -m_Z c_w \sin \beta & -\mu & 0 \end{pmatrix}, \quad (3)$$

with $(c_w, s_w) = (\cos \theta_w, \sin \theta_w)$. This matrix depends on parameters m_1 , m_2 , μ , of which m_2 can be chosen to be positive. In grand unified or gauge-mediated models of supersymmetry-breaking, $m_1 = 0.5m_2$, and I will assume this in computing the curves displayed in this paper. However, it is important to state that this ratio could have a wide range of values and must ultimately be determined experimentally.

The eigenstates of the matrix (3) change qualitatively depending on whether $m_2 > |\mu|$ or $m_2 < |\mu|$. In the first case, the lightest neutralino is approximately the \tilde{b} . We might call this the ‘gaugino’ region. In the second case, the lightest neutralino is a linear combination of the two Higgsinos. This is the ‘Higgsino’ region. The crossover between these two regions is illustrated in Figure 1, in which I show the dependence of the masses of the four neutralinos $\tilde{\chi}_i^0$ and also of the two charginos $\tilde{\chi}_i^\pm$ on the ratio m^2/μ , for parameters that keep the mass of the lightest neutralino fixed.

Typically, the whole pattern of decays of supersymmetric particles is affected by the value of m_2/μ , so this parameter must be determined accurately to carry out any precision studies. We will see that the various processes (1) and (2) are nicely sensitive to m_2/μ and m_1/m_2 .

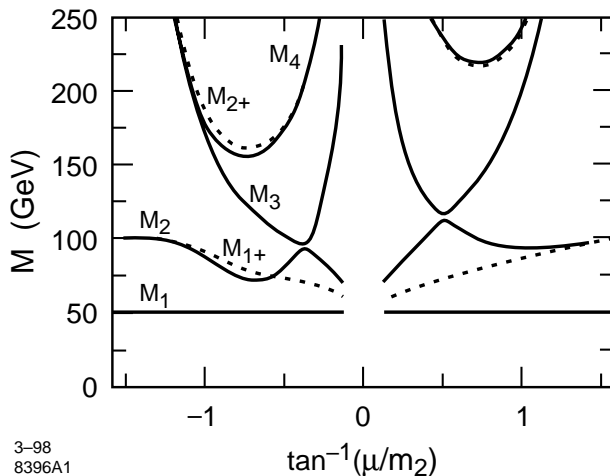

Fig. 1. The spectrum of neutralinos displayed as a function of $\tan^{-1}(\mu/m_2)$, for $\tan\beta = 4$, along a line in parameter space for which the mass of the lightest neutralino is 50 GeV.

The eigenstates of the mass matrix (3) enter the theory of e^+e^- and e^-e^- scattering because the gaugino components of the neutralino mediate the transitions from electron to selectron states. Write the diagonalization of the matrix (3) as

$$\mathbf{m} = V D V^\dagger, \quad (4)$$

where D is a diagonal matrix whose eigenvalues are M_i , $i = 1, \dots, 4$, arranged in ascending order by absolute value. Then, for example, V_{1i} gives the \tilde{b} admixture in the neutralino i . To present formulae for the e^+e^- and e^-e^- processes of interest, let

$$V_{Li} = \frac{1}{2c_w} V_{1i} + \frac{1}{2s_w} V_{2i}, \quad V_{Ri} = \frac{1}{c_w} V_{1i}. \quad (5)$$

From these objects, we can construct the dimensionless *neutralino functions*,

$$\begin{aligned} N_{ab}(t) &= \sum_i V_{ai} \frac{M_1^2}{M_i^2 - t} V_{bi}^* \\ M_{ab}(t) &= \sum_i V_{ai} \frac{M_1 M_i}{M_i^2 - t} V_{bi}, \end{aligned} \quad (6)$$

with $a, b = L, R$. If we can ignore CP violation, $N_{LR} = N_{RL}$, and, similarly, $M_{LR} = M_{RL}$. The neutralino functions $M_{ab}(t)$ enter the amplitudes for the e^+e^- and e^-e^- processes which require a helicity flip, and the functions $N_{ab}(t)$ enter the amplitudes for those processes which are helicity-conserving.

All of the neutralino functions must tend to zero in the Higgsino limit. However, it turns out that they are still quite substantial for fairly large values of $m_2/|\mu|$. The dependence of the six possible functions on m_2/μ is shown in Figure 2

The neutralino functions typically have a simple monotonic decrease with $|t|$. When we make use of them, we should think about extrapolating them to $t = 0$. In

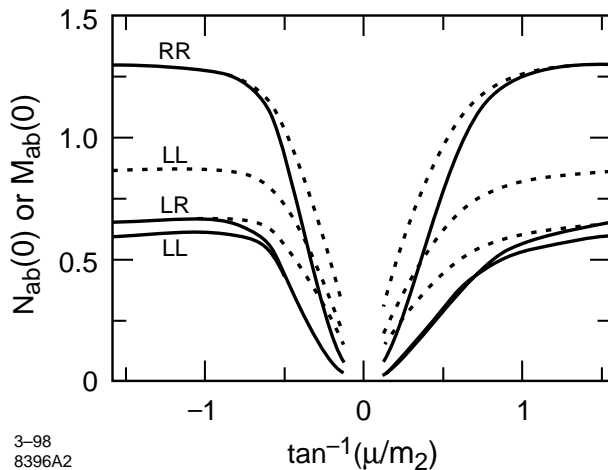

Fig. 2. The six neutralino functions, evaluated at $t = 0$, displayed as functions of $\tan(\mu/m_2)$, for $\tan\beta = 4$, along the line in parameter space for which the mass of the lightest neutralino is 50 GeV. The functions N_{ab} are drawn as solid lines, the M_{ab} as dotted lines.

the gaugino limit, the values of these functions take simple values at $t = 0$ for the cases $ab = RR, LR$:

$$N_{RR}(0), M_{RR}(0) \rightarrow \frac{1}{c_w^2} \quad N_{LR}(0), M_{LR}(0) \rightarrow \frac{1}{2c_w^2}. \quad (7)$$

To the extent that these predictions are not obeyed, the lightest neutralino must have substantial Higgsino content. On the other hand, the $t \rightarrow 0$ limit of the LL neutralino functions varies with the ratio m_1/m_2 :

$$M_{LL}(0) \rightarrow \frac{1}{4c_w^2} + \frac{1}{4s_w^2} \frac{m_1}{m_2} \quad M_{LL}(0) \rightarrow \frac{1}{4c_w^2} + \frac{1}{4s_w^2} \frac{m_1^2}{m_2^2}. \quad (8)$$

The measurement of these functions then can be used to fix the value of the ratio of gaugino masses.

3. Cross Sections

In writing the cross sections for selectron production, I will denote the superpartner of the right-handed electron by \tilde{e}_R and the superpartner of the left-handed electron by \tilde{e}_L . These particles of course are scalars and carry zero spin. But the labels help in tracking how the initial-state lepton helicity flows to the final-state particles. It is important to keep in mind, when discussing e^+e^- reactions, that the e_R^+ goes with the e_L^- and vice versa. In e^-e^- reactions, the helicity flow is transparent. It is also important to remember that, in most models, the \tilde{e}_R and \tilde{e}_L have masses which are substantially different. In the simplest models, the \tilde{e}_L is heavier by a factor 1.3–2.5. So it is likely that the production of the two species of selectron can be distinguished kinematically.

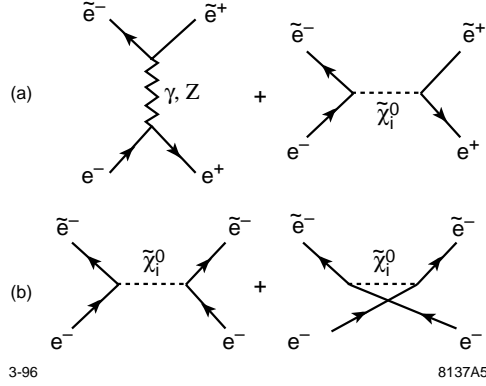

Fig. 3. Feynman diagrams contributing to the reactions (a) $e^+e^- \rightarrow \tilde{e}^+\tilde{e}^-$, (b) $e^-e^- \rightarrow \tilde{e}^-\tilde{e}^-$.

The Feynman diagrams for the reactions $e^+e^- \rightarrow \tilde{e}^+\tilde{e}^-$ and $e^-e^- \rightarrow \tilde{e}^-\tilde{e}^-$ are shown in Figure 3. Each possible final state couples to precisely one combination of initial electron and electron-positron helicities, and also to one neutralino function. Thus, each physically distinguished cross section is the square of a single helicity amplitude.

I will now give a list of formulae for $d\sigma/d\cos\theta$ in the center of mass frame for each possible reaction. I denote the selectron velocity by β ; for reactions with unequal masses in the final state, $\beta = 2k/\sqrt{s}$, where k is the common value of the final-state momentum. Then we find

$$\begin{aligned}
e_R^- e_L^+ \rightarrow \tilde{e}_R^- \tilde{e}_L^+ &: \frac{\pi\alpha^2}{2s} \beta^3 \sin^2 \theta \left| \frac{s}{M_1^2} N_{RR}(t) - \left(1 + \frac{s_w^2}{c_w^2} \frac{s}{s - m_Z^2}\right) \right|^2 \\
e_R^- e_L^+ \rightarrow \tilde{e}_L^- \tilde{e}_L^+ &: \frac{\pi\alpha^2}{2s} \beta^3 \sin^2 \theta \left| 1 - \frac{\frac{1}{2} - s_w^2}{c_w^2} \frac{s}{s - m_Z^2} \right|^2 \\
e_R^- e_R^+ \rightarrow \tilde{e}_R^- \tilde{e}_L^+ &: \frac{2\pi\alpha^2}{s} \beta \frac{s}{M_1^2} |M_{LR}(t)|^2 \\
e_L^- e_L^+ \rightarrow \tilde{e}_L^- \tilde{e}_R^+ &: \frac{2\pi\alpha^2}{s} \beta \frac{s}{M_1^2} |M_{LR}(t)|^2 \\
e_L^- e_R^+ \rightarrow \tilde{e}_R^- \tilde{e}_R^+ &: \frac{\pi\alpha^2}{2s} \beta^3 \sin^2 \theta \left| 1 - \frac{\frac{1}{2} - s_w^2}{c_w^2} \frac{s}{s - m_Z^2} \right|^2 \\
e_L^- e_R^+ \rightarrow \tilde{e}_L^- \tilde{e}_L^+ &: \frac{\pi\alpha^2}{2s} \beta^3 \sin^2 \theta \left| \frac{s}{M_1^2} N_{LL}(t) - \left(1 + \frac{(\frac{1}{2} - s_w^2)^2}{c_w^2 s_w^2} \frac{s}{s - m_Z^2}\right) \right|^2 \\
e_R^- e_R^- \rightarrow \tilde{e}_R^- \tilde{e}_R^- &: \frac{2\pi\alpha^2}{s} \beta \frac{s}{M_1^2} |M_{RR}(t) + M_{RR}(u)|^2 \\
e_L^- e_R^- \rightarrow \tilde{e}_L^- \tilde{e}_R^- &: \frac{\pi\alpha^2}{2s} \beta^3 \sin^2 \theta \left| \frac{s}{M_1^2} N_{LR}(t) \right|^2 \\
e_L^- e_L^- \rightarrow \tilde{e}_L^- \tilde{e}_L^- &: \frac{2\pi\alpha^2}{s} \beta \frac{s}{M_1^2} |M_{LL}(t) + M_{LL}(u)|^2. \tag{9}
\end{aligned}$$

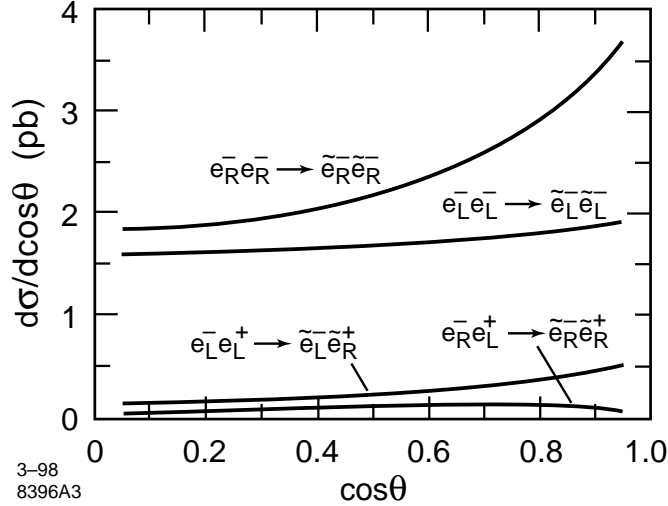

Fig. 4. Differential cross sections for four slepton production processes, computed at a point in the Higgsino region, with $m_2/\mu = -5$ for $\tan\beta = 4$. I have taken $M_1 = 50$, $m(e_R) = 150$, $m(e_L) = 200$, $\sqrt{s} = 500$ GeV.

In formulae with identical particles in the final state, $d\sigma/d\cos\theta$ is to be integrated over $0 \leq \cos\theta \leq 1$ only. Note that, in amplitudes in which the s channel contributions interfere with the t -channel neutralino exchange, it is typically the neutralino exchange that dominates.

From this table, we see that the reactions which produce $\tilde{e}_R\tilde{e}_R$ are already useful for determining whether we are in the gaugino or Higgsino region of the neutralino mixing problem. The reactions which produce $\tilde{e}_L\tilde{e}_L$ are the ones which are most sensitive to the ratio m_1/m_2 . For both of these final states, e^-e^- reactions have the interesting advantage that the amplitude near threshold is s -wave, and so the cross section behaves like β rather than β^3 . Depending on the kinematics, this difference can give a very substantial advantage in the size of the cross section to e^-e^- . In addition, the e^-e^- reactions have no destructive interference from the s -channel diagrams. Just as one illustration of these effects, I plot in Figure 4 the cross sections for the most important reactions at a point in the Higgsino region where $m_2/\mu = -5$.

4. Conclusions

We have seen that the reactions $e^+e^- \rightarrow \tilde{e}^+\tilde{e}^-$ and $e^-e^- \rightarrow \tilde{e}^-\tilde{e}^-$ have a wonderful formal simplicity. By measuring these cross sections, especially with polarized initial-state particles, we have a direct way to measure the parameters of neutralino mixing. We have also seen that e^-e^- has a certain advantage in these studies, both in the size of cross sections and in the simplicity of the backgrounds which must be controlled.

The simplicity of the e^-e^- reactions also give them an advantage in probing

more sophisticated aspects of the electron-electron coupling. That is the subject of the presentations of Cheng, Feng, and Thomas to these proceedings.

Acknowledgements

I am grateful to Clemens Heusch, Nora Rogers, and their colleagues at the University of California, Santa Cruz, for arranging this pleasant and fruitful conference.

References

1. M. E. Peskin, in *Prog. Theor. Phys. Suppl.* **123**, 507 (1996), hep-ph/9604339.
2. H. Murayama, in *Perspectives in Supersymmetry*, G. Kane, ed. (World Scientific, Singapore, 1998), hep-ph/9801331.
3. F. Cuypers, G. J. van Oldenbourgh, and R. Rückl, *Nucl. Phys. B* **409**, 128 (1993).
4. F. Cuypers, in *Physics and Experiments with Linear Colliders*, A. Miyamoto, Y. Fujii, T. Matsui, and S. Iwata, eds. (World Scientific, Singapore, 1996), hep-ph/9512201.
5. F. Cuypers, *Int. J. Mod. Phys. A* **11**, 1585 (1996), hep-ph/9603243.
6. H. Baer, A. Bartl, D. Karatas, W. Majerotto, and X. Tata, *Int. J. Mod. Phys. A* **4**, 4111 (1989).
7. H. Haber and G. Kane, *Phys. Repts.* **117**, 75 (1985).
8. T. Tsukamoto, K. Fujii, H. Murayama, M. Yamaguchi, and Y. Okada, *Phys. Rev. D* **51**, 3153 (1995).
9. M. M. Nojiri, K. Fujii, and T. Tsukamoto, *Phys. Rev. D* **54**, 6756 (1996), hep-ph/9606370.