

SLAC-PUB-7553

DOE/ER/40561-330-INT97-19-07

DOE/ER/41014-16-N97

July 1997

Is J/ψ -Nucleon Scattering Dominated by the Gluonic van der Waals Interaction? *

Stanley J. Brodsky

Stanford Linear Accelerator Center
Stanford University, Stanford, California 94309

Gerald A. Miller †

Stanford Linear Accelerator Center
Stanford University, Stanford, California 94309
and
National Institute for Nuclear Theory
Box 35150, University of Washington
Seattle, Washington 98195-1560

Abstract

The gluon-exchange contribution to J/ψ -nucleon scattering is shown to yield a sizeable scattering length of about -0.25 fm, which is consistent with the sparse available data. Hadronic corrections to gluon exchange which are generated by $\rho\pi$ and $D\bar{D}$ intermediate states of the J/ψ are shown to be negligible. We also propose a new method to study J/ψ -nucleon elastic scattering in the reaction $\pi^+d \rightarrow J/\psi p p$.

Submitted to Physics Letters B.

*Work supported in part by the Department of Energy, contract DE-AC03-76SF00515.

†Permanent address: Department of Physics, Box 351560, University of Washington, Seattle, Washington 98195-1560

One of the novel features that quantum chromodynamics brings to strong interaction physics is the concept of a gluonic van der Waals potential, the interaction arising from the exchange of two or more gluons between color-singlet hadrons. The color van der Waals potential is expected to be the dominant potential in the case of the scattering of hadrons without common quarks, such as in the interaction of heavy quarkonium states with hadrons or nuclei at low energies. As in quantum electrodynamics, the QCD van der Waals is attractive, and in principle it could lead to molecular-like bound states of charmonium with nuclei[1, 2]. Unlike QED, the QCD van der Waals potential has finite range, rather than the power-law fall-off characteristic of the exchange of massless neutral gauge fields.[3]

It is clearly very interesting to study the theoretical foundations and the empirical consequences of the van der Waals potential. In an illuminating paper, Luke, Manohar, Savage[4] have shown that the essential features of the low energy interaction between heavy quarkonium and nucleons or nuclei can be determined directly from the operator product expansion. In their analysis the coupling of multiple gluons to a small-size quarkonium bound state is given by the quarkonium color electric polarizability. The coupling of the gluons to the large-size nucleon or nucleus depends on one term proportional to the momentum fraction carried by gluons and a second term normalized to the nucleon or nuclear mass. The dominant low energy interaction at small relative velocity corresponds to scalar exchange. The gluon exchange potential can then lead to resonances or even bound states in quarkonium-hadron or quarkonium-nuclear interactions. Such novel states could be seen for example as kinematical peaks in the decay of the B meson in the $\bar{p}\Lambda J/\psi$ final state.[5]

The main purpose of this letter is to demonstrate explicitly that the QCD van der Waals potential as characterized by its scattering length is indeed much more important than the meson-exchange forces in J/ψ -nucleon interactions which arise from the coupling of charmonium to hadronic intermediate states. We also point out that the QCD van der Waals interaction can be conveniently studied experimentally in the highly-constrained reaction $\pi d \rightarrow J/\psi pp$.

Indirect information on the interactions of the $c\bar{c}$ system with nucleons can also be obtained from studies of charm production at threshold or, via unitarity, the behavior of pp elastic scattering in the charm threshold region. Indeed the strong increase of the polarization asymmetry A_{NN} observed in Ref. [6] in large CM angle proton-proton

scattering at $\sqrt{s} \simeq 5$ GeV has been attributed to the strong interactions between charm anti-charm configurations arising in the intermediate state interacting with nucleons at low relative velocity[7]. It would clearly be very useful to verify these physical features from direct measurements of the J/ψ -nucleon interaction.

We begin by deriving the scattering length for the QCD van der Waals potential, starting with the Luke, Manohar, Savage LMS two-gluon exchange calculation of the forward invariant amplitude in first Born approximation:

$$\mathcal{M}_{\text{fwd}} = 4M_\psi M^2 \frac{c_E}{\Lambda_Q^3} \left[\frac{3}{4} V_2(\Lambda_Q) + \frac{2\pi}{\beta_Q \alpha_s(\Lambda_Q)} \right]. \quad (1)$$

Here M is the nucleon mass and V_2 is the gluon momentum fraction in the nucleon. (We take $V_2 = 0.5$ [8] at the low momentum transfer scale relevant here.) LMS assumed the heavy quark limit, in which the size of the heavy quarkonium system, $r_B \sim 1/m_Q$ is much smaller than the inverse of the QCD scale Λ_{QCD}^{-1} , and in which the $Q\bar{Q}$ system can be approximated as a Coulomb bound state. Peskin [9] found

$$\frac{c_E}{\Lambda_Q^3} = \frac{14\pi}{27} r_B^3 \quad (2)$$

where r_B is the Bohr radius of the $1s$ state. The LMS analysis is a rigorous prediction of QCD, and it is completely model independent in the limit $m_Q \rightarrow \infty$. Although the validity of the Coulomb approximation for the J/ψ may not be completely reliable, this result should provide a good estimate for c_E . The LMS computation shows unambiguously that the potential is attractive.

The parameters appearing in Eq. (1) must be specified to obtain numerical results. The Bohr radius of the J/ψ has been determined in the model-independent analysis of Quigg and Rosner [10] as $r_B^{-1} = 750$ MeV. The value of the strong coupling constant at low momentum transfer scales $Q \sim r_B^{-1}$ can be determined in the α_V scheme from various exclusive processes [11]. A convenient parameterization which freezes the coupling at low scales is

$$\frac{2\pi}{\beta_Q \alpha_V(Q)} = \frac{1}{2} \ln \left(\frac{Q^2 + 4 m_g^2}{\Lambda_V^2} \right), \quad (3)$$

with $m_g^2 = 0.2$ GeV² and $\Lambda_V = 0.16$ GeV. We now use the relation $f_B = \frac{-\mathcal{M}_{\text{fwd}}}{8\pi(M+M_\psi)}$ [12] to obtain the first Born forward scattering amplitude with the traditional normalization used in potential theory. At threshold $f_B = a_B$, the Born approximate

scattering length. The numerical evaluation of Eq. (1) using the above parameters gives $a_B = -0.19$ fm.

We can go beyond the Born approximation to obtain the full scattering length a by assuming a specific form for the potential $V(r)$ in the Schrodinger equation. The relation between the a_B and $V(r)$ is:

$$a_B = 2\mu \int_0^\infty dr r^2 V(r), \quad (4)$$

where μ is the reduced mass of the J/ψ -nucleon system. Since the QCD van der Waals potential is of finite range, we shall assume a Gaussian shape: $V(r) = -V_0 e^{-r^2/R^2}$ with $R=0.8$ fm chosen to account for the finite sizes of the nucleon, the J/ψ and the range of their interaction. Equation (4) implies then that the potential depth is $V_0 = 23$ MeV, which is quite large. Solving the Schrodinger equation then gives $a = -0.24$ fm, corresponding to a total cross section $\sigma_{\psi N} = 4\pi a^2$ of about 7 mb at threshold. This is somewhat higher than the values $\sigma_{\psi N} = 3.5 \pm 0.8$ mb ± 0.5 mb determined from nuclear J/ψ photoproduction at 20 GeV [13]. However the low energy J/ψ -nucleon interaction corresponds to scalar exchange, implying a cross section which decreases as the energy is increased from threshold. Thus the low-energy value of 7 mb is not inconsistent with the higher energy determination. This number does not depend much on the shape of the potential, for a fixed value of a_B , as long as the range is held fixed.

One possible signal for a strong $c\bar{c}$ interaction with nucleons is the abrupt rise of the polarization asymmetry A_{NN} observed in large CM angle proton-proton elastic scattering at $\sqrt{s} \simeq 5$ GeV near the charm threshold. De Teramond and collaborators[14] have argued that reproducing the strength of the polarization asymmetry \sqrt{s} in the vicinity of the threshold for $c\bar{c}$ production (about 10 GeV) requires an effective scattering length of about the same size as our result. We note that the estimate of Ref. [14] includes the interactions of an ensemble of quarkonium states whose interactions with nucleons could be different than that of the J/ψ .

Does multiple-gluon exchange really dominate over all other strong interaction effects in J/ψ -nucleon scattering? It is natural to consider the effects involving the exchange of pions between the J/ψ and the nucleon. Isospin conservation prevents the exchange of a single pion, but the two-pion exchanges generated by contact interactions which take a J/ψ into a $J/\psi\pi\pi$ state are allowed. In the LMS formalism,

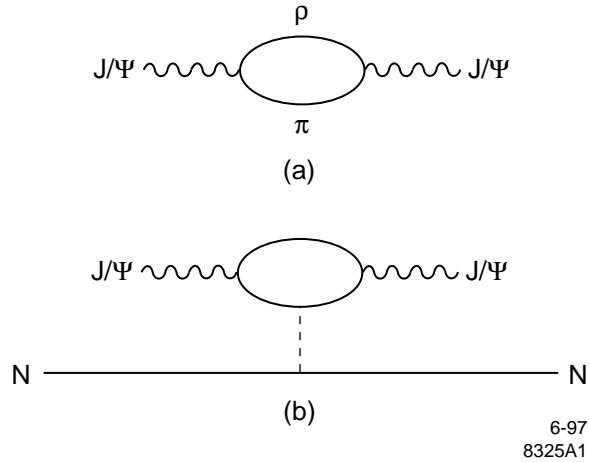

Figure 1: Influence of $\rho\pi$ intermediate states on M_ψ . (a) free J/ψ (b) typical graph for J/ψ in the presence of a nucleon

such terms owe their existence to non-vanishing masses of the light quarks. Their size is of order $(\frac{m_\pi}{4\pi f_\pi})^2 \approx 1\%$ of the terms in Eq. (1)[4].

But there could be other types of hadronic interactions. To investigate the possibilities we look at the hadronic width of the J/ψ . The J/ψ decay to $\rho\pi$ has a remarkably large 1.28 % branching fraction of the 87 KeV width [12], an effect which has been attributed to the intrinsic charm Fock states of the ρ and π mesons [15]. Thus the J/ψ could interact with a nucleon via virtual $\rho\pi$ interactions, as in Fig. 1b. In order to estimate the strength of such meson-exchange contributions, we postulate a hadronic Lagrangian of the form

$$\mathcal{L}_{\rho\pi} = g\bar{\psi}_\mu \boldsymbol{\rho}^\mu \cdot \boldsymbol{\pi}, \quad (5)$$

the simplest interaction term consistent with isospin and space-time symmetries. The coupling g is readily determined from the width to the $\rho\pi$ channel:

$$\Gamma_{\rho\pi} = \frac{g^2}{8\pi} \left(3 + \frac{p_1^2}{M_\rho^2}\right) \frac{p_1}{M_\psi^2}, \quad (6)$$

where p_1 is the relative momentum of the $\rho\pi$ system, $p_1 = 0.47M_\psi$. Then $g = \epsilon M_\psi$ with $\epsilon = 1.7 \times 10^{-3}$.

Given a value of g we may compute the scattering amplitude due to the graphs of Fig. 1. We use relativistic time-ordered perturbation theory to obtain the J/ψ -

nucleon interaction where the time ordering corresponds to the intermediate state $\rho\pi$ plus the nucleon. Our procedure will be to first consider the free-space amplitude of Fig. 1a which contributes to the mass of the J/ψ and then see how this mass shift is modified by the presence of the nucleon. Let $V_\psi^{(0)}$ be the shift in the mass of the J/ψ due to the $\rho\pi$ channel:

$$\begin{aligned} V_\psi^{(0)} &= \langle \psi | V_{\rho\pi} \frac{1}{E - H_0 + i\epsilon} V_{\rho\pi} | \psi \rangle \\ &= \frac{\Gamma_{\rho\pi} M_\psi}{2\pi p_1} Re \int_0^\infty \frac{q^2 dq}{E_\pi E_\rho} \frac{1}{(E - E_\pi - E_\rho + i\epsilon)} \end{aligned} \quad (7)$$

where $E = M_\psi$ for the on-shell J/ψ . Here H_0 accounts for the sum of the relativistic kinetic energies $E_\pi = \sqrt{q^2 + M_\pi^2}$, $E_\rho = \sqrt{q^2 + M_\rho^2}$ of the ρ and π , and $V_{\rho\pi}$ is the interaction Hamiltonian derived from $\mathcal{L}_{\rho\pi}$. Note that $Im V_\psi^{(0)} = -\frac{\Gamma_{\rho\pi}}{2}$. The mass shift is modified in the presence of a nucleon:

$$V_\psi = \langle \psi, N | V_{\rho\pi} \frac{1}{E - H_0 - V_N + i\epsilon} V_{\rho\pi} | \psi, N \rangle \quad (8)$$

where V_N is the strong interaction potential arising between the ρ and the π and the nucleon.

The J/ψ -nucleon interaction $V(\psi, N)$ that we seek is given by the difference $V(\psi, N) = Re(V_\psi - V_\psi^{(0)})$ as in the Furry picture. The evaluation of Eqs. (7) and (8) is complicated; however, for our purposes we can make an estimate by taking V_N to be a constant. Thus to first order in V_N we find

$$V(\psi, N) \approx \frac{V_N}{M_\psi - M_\rho - M_\pi} \frac{\Gamma_{\rho\pi} M_\psi}{2\pi p_1}. \quad (9)$$

The small value of $\Gamma_{\rho\pi}$ ($= 1.1$ KeV) causes $V(\psi, N)$ to be of the order of 10^{-5} MeV, which is entirely negligible.

Another type of term is shown in Fig. 2, which is driven by the coupling of the J/ψ to a pair of D mesons. The J/ψ is stable with respect to this decay, but it could lead to an interaction with nucleons through the virtual intermediate states. A significant interaction could be possible even at low energies since the anti-light quark could be absorbed and the charmed quark added to the nucleon to make an intermediate Λ_c . We again use a hadronic effective Lagrangian

$$\mathcal{L}_{D\bar{D}} = i g_c \psi^\mu \left(\bar{\mathbf{D}} \partial_\mu \cdot \mathbf{D} - \mathbf{D} \partial_\mu \cdot \bar{\mathbf{D}} \right). \quad (10)$$

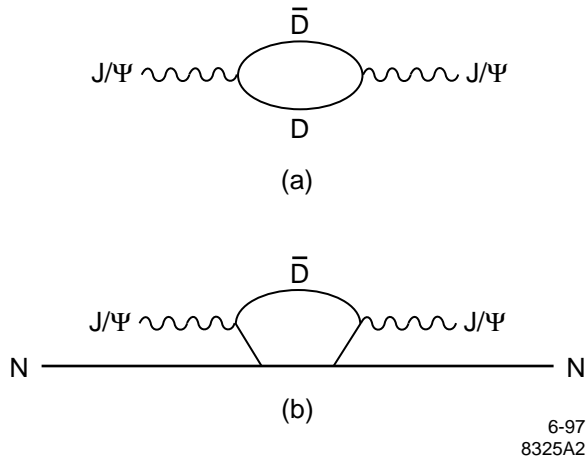

Figure 2: Influence of $\bar{D}D$ intermediate states on M_ψ . (a) free J/ψ (b) J/ψ in the presence of a nucleon, sample graph. The intermediate baryon carries charm.

We cannot obtain g_c from the width of the J/ψ , so we shall extrapolate from the decay of the ϕ using an interaction

$$\mathcal{L}_{K\bar{K}} = i g_s \phi^\mu (\bar{\mathbf{K}} \partial_\mu \cdot \mathbf{K} - \mathbf{K} \partial_\mu \cdot \bar{\mathbf{K}}). \quad (11)$$

which also involves a vector meson decaying into two pseudoscalar particles. We take g_s from the decays $\phi \rightarrow K^0 \bar{K}^0$ and $\phi \rightarrow K^+ K^-$. A simple evaluation gives $\frac{g_s^2}{4\pi} = 1.71$.

Obtaining the relation between g_c and g_s is the next task. The key feature is the small-sized nature of the J/ψ . We recall that the small size of the region involved in $c\bar{c}$ annihilation was the crucial ingredient in the Appelquist-Politzer[16] explanation of the very small hadronic width of the J/ψ . This is because the amplitudes for gluons emitted by a charmed and nearby anti-charmed quark tend to cancel. Taking the emission of the light-quark pair to be governed by two gluon-exchange, as in the LMS example, leads to a transition amplitude given by the matrix element of the operator r representing the distance between the heavy quarks. The power arises from the small size of the initial system. A related example, [17, 18] is the ratio of the decay amplitudes for Υ' and ψ' to decay to their ground states and two pions which is governed by the ratio of the mean square radii[17]. In that case, both the initial (Υ' , ψ') and final (Υ , ψ) states involve small systems, so that one obtains two powers of r . We also note that the ratio of the same decays of the ψ' and the ρ' is very

small[12]. Another related example occurs when considering the coupling constant for pions to interact with the point-like configuration of the nucleon[18]. In that case, the coupling also varies as the area of the point-like configuration. Thus we expect that

$$g_c \approx g_s \frac{R_\psi}{R_\phi} \quad (12)$$

Using the root-mean-square radii $R_\psi = 0.11$ fm [10] and $R_\phi = 0.4$ fm[19] leads to

$$\frac{g_c^2}{4\pi} \approx 0.13. \quad (13)$$

We shall evaluate the contribution to the J/ψ -nucleon interaction coming from Fig. 2 by examining how the shift in M_ψ^2 of Fig. 2a, $\Delta M_\psi^2(M_D^2)$, changes in the presence of a nucleon, modelling the effect of the nucleon with the replacement $M_D \rightarrow M_D + V(D, N)$. The D -nucleon interaction $V(D, N)$ is treated as a constant. The resulting contribution to the ψ -N potential $V(\psi, N)$ is then given by

$$V(\psi, N) = \frac{\partial \Delta M_\psi^2}{\partial M_D^2} \frac{M_D}{M_\psi} V(D, N), \quad (14)$$

with

$$\Delta M_\psi^2(M_D^2) = i g_c^2 \int \frac{d^4 k}{(2\pi)^4} \frac{(\epsilon(\lambda) \cdot (2k - P))^2}{(k^2 - M_D^2 + i\epsilon) ((k - P)^2 - M_D^2 + i\epsilon)}, \quad (15)$$

where P is the four momentum of the J/ψ , and $\epsilon(\lambda)$ its polarization vector. We average over the J/ψ polarization λ and combine the energy denominators to obtain:

$$\Delta M_\psi^2(M_D^2) = i g_c^2 \int_0^1 dx \int \frac{d^4 k}{(2\pi)^4} \frac{k^2}{(k^2 - \Delta(x))^2}, \quad (16)$$

where $\Delta(x) \equiv M_D^2 - M_\psi^2 x(1-x) + i\epsilon > 0$. This term can be renormalized via the dimensional regularization procedure, corresponding to the removal of an infinite term independent of M_D^2 which does not contribute to $V(\psi, N)$ of Eq. (14). In particular, we replace the factor of k^2 appearing in the numerator of Eq. (16) by $\Delta(x)$. Then

$$\frac{\partial \Delta M_\psi^2}{\partial M_D^2} = 2 i g_c^2 \int_0^1 dx \int \frac{d^4 k}{(2\pi)^4} \frac{\Delta(x)}{(k^2 - \Delta(x))^3} = \frac{1}{4\pi} \frac{g_c^2}{4\pi}, \quad (17)$$

and

$$V(\psi, N) = \frac{1}{4\pi} \frac{g_c^2}{4\pi} \frac{M_D}{M_\psi} V(D, N) = 0.006 V(D, N). \quad (18)$$

We may obtain an upper limit for $V(D, N)$ by assuming that the D -nucleon and π -nucleon interactions are similar. The π -N interaction corresponds [20] to a strength of

approximately 1 MeV near threshold and about 20 MeV for pions of 100 MeV. Thus, the estimated value of $V(\psi, N)$ is less than about 0.1 MeV and negligible compared to the 23 MeV from multiple gluon exchange.

The net conclusion is that the QCD van der Waals potential for J/ψ -nucleon interactions from gluon exchange is strongly dominant over meson-exchange interactions.

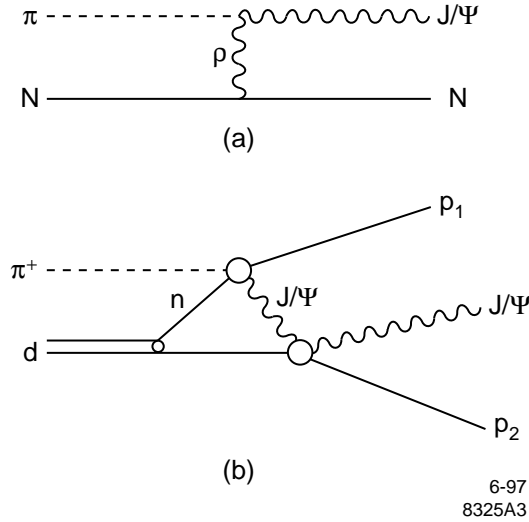

Figure 3: (a) The production process $\pi^+ n \rightarrow J/\psi p$. (b) The production process $\pi^+ d \rightarrow J/\psi p_1 p_2$.

It is clearly interesting and important to measure $J/\psi N$ scattering. The traditional and most straightforward method is to analyze the nuclear dependence of J/ψ photoproduction.[21] However, the $\rho\pi$ interaction offers the opportunity to measure the $J/\psi N$ interaction in a totally exclusive situation. Consider the process $\pi^- p \rightarrow \psi n$ which proceeds by ρ exchange as shown in Fig. 3. The cross section for this process is easily evaluated. In the limit $s \gg M_\psi^2$

$$\frac{d\sigma_{\pi N \rightarrow \psi N}}{dt} = \frac{1}{2} \frac{g_{\rho N}^2}{4\pi} \epsilon^2 \frac{F^2(t)}{(t - M_\rho^2)^2}, \quad (19)$$

where the ρ -nucleon coupling constant $\frac{g_{\rho N}^2}{4\pi} = 1$, and $F(t)$ is the ρ -nucleon form factor. We find $\frac{d\sigma_{\pi N \rightarrow \psi N}}{dt}(t = 0) = 1.6 \text{ nb GeV}^{-2}$. This may be compared with the

photoproduction cross section of 10 nb GeV^{-2} observed in $\gamma p \rightarrow \psi p$ [21], and thus it is not too small to be observed. The total cross section for this J/ψ production process is approximately 1 nb. In principle, one can also use this reaction to search for $J/\psi - N$ resonances or even $J/\psi - N$ bound states.

More generally one can study multiple-scattering corrections to the process $\pi N \rightarrow \psi N$ in a nuclear target and thus measure how the J/ψ scatters on a nucleon. For example, consider the deuteron target process $\pi^+ d \rightarrow J/\psi + p_1 + p_2$ as shown in Fig. 3b. The process $\pi^+ + \text{neutron} \rightarrow J/\psi$ plus proton of momentum p_1 is followed by a $J/\psi + \text{proton}$ scattering. If the momentum p_2 of the second proton is greater than about 300 MeV/c, such an event can only be produced by a scattering [22], because the deuteron wave function does not have appreciable support for such high momenta. The signature of J/ψ production is a monoenergetic peak in the missing mass obtained by measuring the two final state nucleons, one of momentum close to that of the beam and the other of greater than 300 MeV/c. Such fixed target measurements would enable the first measurement of J/ψ -nucleon elastic scattering at near threshold energies.

The results presented here demonstrate that the exchange of two gluons in the scalar channel dominates elastic $J/\psi - N$ scattering. The most logical hadronic mechanisms which might be competitive are interactions involving $\rho\pi$ or $D\bar{D}$ intermediate states. The contributions to the quarkonium-nucleon potential are found to be very small compared to the predicted color van der Waals strength.

We find that the cross section for exclusive J/ψ production in pion-nucleon collisions $\pi^+ d \rightarrow J/\psi + p_1 + p_2$ is not negligible, enabling a very clean measurement of the magnitude and momentum dependence of J/ψ -N elastic scattering at low energies. Such measurements could test the first-principle theoretical predictions for the QCD van der Waals interaction.

Acknowledgments

This work is partially supported by the USDOE. G. A. Miller thanks the SLAC theory group, the National Institute for Theoretical Physics and the Adelaide center for their hospitality. We also thank M. Savage for a useful discussion.

References

- [1] S. J. Brodsky, I. Schmidt and G. F. de Téramond, Phys. Rev. Lett. **64**, 1011 1990.
- [2] D. A. Wasson, Phys. Rev. Lett. **67**, 2237 1991.
- [3] For a recent review of the QED van der Waals potential see J. Sucher, e-Print Archive: hep-ph/96123
- [4] M. Luke, A. V. Manohar and M. J. Savage, Phys. Lett.**B288**, 355 (1992).
- [5] S. J. Brodsky, F. S. Navarra, SLAC-PUB-7445, to appear in Phys. Lett. B, e-Print Archive: hep-ph/9704348
- [6] E. A. Crosbie, *et al.*Phys. Rev.**D23**, 600 (1981).
- [7] S. J. Brodsky, G. F. de Téramond Phys.Rev.Lett.**60**, 1924 (1988).
- [8] See, for example, R. D. Field, *Applications of Perturbative QCD*, Addison-Wesley Publishing Company, 1989.
- [9] M. E. Peskin, Nucl. Phys. **B156**, 365 (1979).
- [10] C. Quigg and J. L. Rosner, Phys. Rev. **D23** 1981 2625.
- [11] S. J. Brodsky, C.-R. Ji, A. Peng and D. G. Robertson, hep-ph/9705221
- [12] Nucl. Phys. **B156** 1979 R. M. Barnett *et al.*, Phys. Rev. **D54**, 1 (1996)
- [13] R. L. Anderson *et al.*, Phys. Rev. Lett. **38**, 263 (1977).
- [14] G. F. de Téramond, private communication and G. F. de Téramond, R. Espinoza, and M Ortega-Rodríguez, 1997 preprint.
- [15] S. J. Brodsky, M. Karliner SLAC-PUB-7463, Apr 1997. To appear in Phys. Rev. Lett. e-Print Archive: hep-ph/9704379
- [16] T. Appelquist and H. D. Politzer, Phys. Rev. Lett. **34**, 43 (1975); Phys. Rev.. **D12**, 1404 (1975).

- [17] M. Chanowitz, Proc. Summer School in Part. Phys. SLAC-245, p. 241 (1981) ed. A. Mosher
- [18] L. Frankfurt and M. Strikman, Nucl .Phys. **B250**, 143 (1985)
- [19] J. Hufner and P. Povh, Phys. Rev. Lett. **58**, 1612 (1987).
- [20] T. Ericson and W. Weise, *Pions and Nuclei*, Clarendon Press, Oxford, 1988.
- [21] U. Camerini *et al.*, Phys. Rev. Lett. **35**, 483 (1975).
- [22] L. L. Frankfurt, W. R. Greenberg, G. A. Miller, M. M. Sargsyan and M. I. Strikman, Z. Phys. **A352**, 97 (1995); Phys. Lett. **B369**, 201 (1996).