

SLAC-PUB-7463
TAUP 2417-97
hep-ph/9704379
April 1997

Intrinsic Charm of Vector Mesons: A Possible Solution of the “ $\rho\pi$ Puzzle” *

Stanley J. Brodsky

*Stanford Linear Accelerator Center
Stanford University, Stanford, California 94309
e-mail: sjbth@slac.stanford.edu*

and

Marek Karliner

*School of Physics and Astronomy
Raymond and Beverly Sackler Faculty of Exact Sciences
Tel-Aviv University, 69978 Tel-Aviv, Israel
e-mail: marek@vm.tau.ac.il*

ABSTRACT

An outstanding mystery of charmonium physics is why the J/ψ decays prominently to pseudoscalar plus vector meson channels, such as $J/\psi \rightarrow \rho\pi$ and $J/\psi \rightarrow K^*K$, whereas the $\psi'(2S)$ does not. We show that such decays of J/ψ and their suppression for $\psi'(2S)$ follow naturally from the existence of intrinsic charm $|\bar{q}q\bar{c}c\rangle$ Fock components of the light vector mesons.

Submitted to Physical Review Letters.

*Work supported in part by the Department of Energy, contract DE-AC03-76SF00515.

One of the basic tenets of quantum chromodynamics is that heavy quarkonium states such as the J/ψ , ψ' , and Υ must decay into light hadrons via the annihilation of the heavy quark constituents into gluons, as shown in Fig. 1(a). This assumption is motivated by the OZI rule which postulates suppression of transitions between hadrons without valence quarks in common. A central feature of the PQCD analysis is the fact that the annihilation amplitude for quarkonium decay into gluons occurs at relatively short distances $r \simeq 1/m_Q$, thus allowing a perturbative expansion in a small QCD coupling $\alpha_s(m_Q)$.

In this letter we shall challenge the assumption that quarkonium states necessarily decay via intermediate gluon states. We shall argue, in analogy with the analysis [1,2] of the nucleon strangeness content, that the wavefunctions of the light hadrons, particularly vector mesons such as the ρ and K^* , have a non-negligible probability to have higher Fock state components containing heavy quark pairs [3]. The presence of intrinsic charm and bottom in the light hadron wavefunctions then allows transitions between heavy quarkonium and light hadrons by rearrangement of the underlying quark lines, rather than by annihilation.

One of the most dramatic problems confronting the standard picture of quarkonium decays is the $J/\psi \rightarrow \rho\pi$ puzzle [4]. This decay occurs with a branching ratio of $(1.28 \pm 0.10)\%$ [5], and it is the largest two-body hadronic branching ratio of the J/ψ . The J/ψ is assumed to be a $\bar{c}c$ bound state pair in the $\Psi(1S)$ state. One then expects the $\psi' = \Psi(2S)$ to decay to $\rho\pi$ with a comparable branching ratio, scaled by a factor ~ 0.15 , due to the ratio of the $\Psi(2S)$ to $\Psi(1S)$ wavefunctions squared at the origin. In fact, $B(\psi' \rightarrow \rho\pi) < 3.6 \times 10^{-5}$ [6], more than a factor of 50 below the expected rate. Most of the branching ratios for exclusive hadronic channels allowed in both J/ψ and ψ' decays indeed scale with their lepton pair branching ratios, as would be expected from decay amplitudes controlled by the quarkonium wavefunction near the origin,

$$\frac{B(\psi' \rightarrow h)}{B(J/\psi \rightarrow h)} \simeq \frac{B(\psi' \rightarrow e^+e^-)}{B(J/\psi \rightarrow e^+e^-)} = 0.147 \pm 0.023 \quad [5,6] \quad (1)$$

where h denotes a given hadronic channel. The $J/\psi \rightarrow \rho\pi$ and $J/\psi \rightarrow KK^*$ decays also conflict dramatically with PQCD hadron helicity conservation: all such pseudoscalar/vector two-body hadronic final states are forbidden at leading twist if helicity is conserved at each vertex [7,8].

The OZI rule states that hadronic amplitudes with disconnected quark lines are suppressed; in QCD this corresponds to the assumption that there is a numerical suppression of amplitudes in which multiple-gluon intermediate states occur. Although the OZI rule has provided a useful guide to the general pattern of hadronic reactions involving strange particle production, there are glaring exceptions: for example, experiments at LEAR have found [9] that in the $\bar{p}p$ annihilation at rest the OZI-violating ratio $B(\bar{p}p \rightarrow \phi\pi/\bar{p}p \rightarrow \omega\pi)$ is enhanced by almost two orders of magnitude compared to the naïve OZI expectations, and that the process $\bar{p}p \rightarrow \phi\phi$ occurs at roughly the same rate as $\bar{p}p \rightarrow \omega\omega$.

The absence of OZI suppression can be understood [1,2] if one takes into account the presence of *intrinsic strangeness* in the proton, *i.e.*, one allows for $|uud\bar{s}s\rangle$ Fock components in the proton wavefunction.[†] The intrinsic strange quarks are part of the hadronic composition of the proton in distinction to *extrinsic strangeness* arising from simple gluon splitting. The $\bar{p}p \rightarrow \phi\pi$ and $\bar{p}p \rightarrow \phi\phi$ amplitudes can then occur simply by rearrangement diagrams in which the strange quarks initially present in the incoming p and \bar{p} appear as the valence components of ϕ mesons in the final state. The OZI rule is *evaded*, since the annihilation of the p and \bar{p} into intermediate gluons is in fact not required.

It is clearly interesting to extend these considerations to the charm and bottom sector. In general, the probability to find heavy quarks or high mass fluctuations in the light hadron wavefunctions which are multi-connected to the valence constituents is suppressed by inverse powers of the relevant mass. For example one can use PQCD to show that the probability for intrinsic charm or bottom Fock states $|uud\bar{Q}Q\rangle$ in the proton wavefunction scales as $1/m_Q^2$ [11]. The light cone wavefunctions for such states, $\Psi_{uud\bar{Q}Q}^p(x_i, k_{\perp i}, \lambda_i)$, peak at the smallest invariant mass of the partons; *i.e.*, at equal rapidity for the constituents. Thus the heavy quarks tend to have the largest momentum fractions $x_i = k_i^+/p^+ \propto m_{\perp i} = (m_i^2 + k_{\perp i}^2)^{\frac{1}{2}}$. In fact the EMC experiment which measured the charm structure function of the nucleon found an excess of events at large Q^2 and x_{bj} well beyond what is expected from photon gluon fusion. Analysis shows that the EMC data are consistent with an intrinsic charm probability of $0.6 \pm 0.3\%$ [12]. There is also a recent interesting proposal to apply

[†]The Fock state expansion may be rigorously defined in a frame-independent way using light-cone Hamiltonian methods [10].

these ideas in order to reconcile the recent HERA data with the Standard Model [13].

An interesting test of intrinsic charm in the proton would be a search for $\bar{p}p \rightarrow J/\psi J/\psi$, $\bar{p}p \rightarrow \phi J/\psi$, $\bar{p}p \rightarrow \omega J/\psi$ above the charm threshold, processes which can occur without annihilation into gluons and thus without OZI suppression because of the presence of charm and strangeness in the initial state. Similarly, exclusive open charm reactions such as $\bar{p}p \rightarrow \bar{\Lambda}_c \Lambda_c$ can occur through rearrangement of the initial charm quark lines.

The discussion and the experimental evidence for the intrinsic charm is usually phrased in terms of the charm content of the nucleon. On the other hand, there is a well known and highly successful phenomenological constituent quark model in which the nucleon contains just three constituent quarks. In order to reconcile the two physical pictures, one is inevitably led to the conclusion that the constituent quarks are themselves complicated composite objects, containing a sea of gluons, light $\bar{q}q$ pairs and a small, but non-negligible $\bar{c}c$ intrinsic charm component. In addition, intrinsic contributions are produced from diagrams which are multiconnected to two or more valence quarks in the nucleon. This then immediately implies that the vector mesons, such as ρ , K^* , etc., also contain an intrinsic charm component, for they are built from the same constituent quarks as the baryons.

The presence of intrinsic charm in light hadrons can also have important consequences [14] for the exclusive hadronic decays of D - and B -mesons, which are usually analyzed by assuming only valence quarks in hadronic states. Any hadron containing a light quark would also be expected to have higher Fock states containing heavy quark pairs by the same type of quantum fluctuations which produce intrinsic strangeness and charm in the nucleon. The surprisingly large branching ratios $D \rightarrow \phi K$ is possibly due to this effect [14].

Let us now re-examine the $J/\psi \rightarrow \rho\pi$ decay, allowing for intrinsic charm in the wavefunctions of the final state hadron. For example, consider the light-cone Fock representation of the ρ : $\rho^+ = \Psi_{u\bar{d}}^\rho |u\bar{d}\rangle + \Psi_{u\bar{d}\bar{c}c}^\rho |u\bar{d}\bar{c}c\rangle + \dots$. The $\Psi_{u\bar{d}\bar{c}c}^\rho$ wavefunction will be maximized at minimal invariant mass; *i.e.* at equal rapidity for the constituents and in the spin configuration where the $u\bar{d}$ are in a pseudoscalar state, thus minimizing the QCD spin-spin interaction. The $\bar{c}c$ in the $|u\bar{d}\bar{c}c\rangle$ Fock state carries the spin projection of the ρ . We also expect the wavefunction of the $\bar{c}c$ quarks to be in an S -wave configuration with no nodes in its radial dependence, in

order to minimize the kinetic energy of the charm quarks and thus also minimize the total invariant mass.

The presence of the $|u\bar{d}\bar{c}c\rangle$ Fock state in the ρ will allow the $J/\psi \rightarrow \rho\pi$ decay to occur simply through rearrangement of the incoming and outgoing quark lines; in fact, the $|u\bar{d}\bar{c}c\rangle$ Fock state wavefunction has a good overlap with the radial and spin $|\bar{c}c\rangle$ and $|u\bar{d}\rangle$ wavefunctions of the J/ψ and pion. Moreover, there is no conflict with hadron helicity conservation, since the $\bar{c}c$ pair in the ρ is in the 1^- state. On the other hand, the overlap with the ψ' will be suppressed, since the radial wavefunction of the $n = 2$ quarkonium state is orthogonal to the node-less $\bar{c}c$ in the $|u\bar{d}\bar{c}c\rangle$ state of the ρ . This simple argument provides a compelling explanation of the absence of $\psi' \rightarrow \rho\pi$ and other vector pseudoscalar-scalar states.[‡]

We can attempt to make a rough estimate of the decay rate $J/\psi \rightarrow \rho\pi$ by comparing it with the measured rate of the analogous decay $\phi \rightarrow \rho\pi$, $\Gamma(\phi \rightarrow \rho\pi) \approx 6 \times 10^{-4}$ GeV [5], assuming that the latter also occurs via coupling to the intrinsic $\bar{s}s$ component in the ρ . Consider the Feynman graph where an $Q\bar{Q}$ is connected to two valence quarks in the wavefunction of the hadron through two hard gluons. This gives a factor of $\alpha_s^2(M_Q^2)$ in the amplitude and thus $\alpha_s^4(M_Q^2)$ in the probability. The same factor occurs in the rearrangement decay rate shown in figure 1(b), since there is implicitly a hard gluon connecting the c with the u and the \bar{c} with the \bar{d} in the ρ wavefunction. Thus, qualitatively, we can estimate that the ratio of probabilities for intrinsic charm to intrinsic strangeness in a light hadron is of order

$$R_{(c\bar{c}/s\bar{s})} \simeq \frac{m_s^2 \alpha_s^4(M_c^2)}{m_c^2 \alpha_s^4(M_s^2)}, \quad (2)$$

which is of the order of 10^{-3} . This is also consistent in order of magnitude with the estimates of the ratio of intrinsic charm to strangeness obtained from deep inelastic scattering on the nucleon. The actual numerical value is uncertain due to the uncertainties in the values of the mass parameters and the running of the coupling at low scales. There may be other suppression factors from the evolution of the light hadron wavefunctions, higher order corrections, etc. In the case of in scattering re-

[‡]The possibility that the radial configurations of the initial and final states could be playing a role in the $J/\psi \rightarrow \rho\pi$ puzzle was first suggested by S. Pinsky [15], who however had in mind the radial wavefunctions of the light quarks in the ρ , rather than the wavefunction of the $\bar{c}c$ intrinsic charm components of the final state mesons.

actions with probes of low resolution, there is an additional screening of the intrinsic sea[16,11], but this type of suppression does not apply to decay amplitudes computed from the overlap of wavefunctions.

The ratio of decay rates for $J/\psi \rightarrow \rho\pi$ to $\phi \rightarrow \rho\pi$ from quark rearrangement should roughly scale with $R_{(c\bar{c}/s\bar{s})}$ times phase space, assuming that the integration over the quarkonium wavefunctions give similar probabilities.[§]

This rough estimates implies $\Gamma(J/\psi \rightarrow \rho\pi) \sim 10^{-6}$ GeV, which is consistent with the measured rate of 10^{-6} GeV.

Our analysis utilizes the fact that quantum fluctuations in a QCD bound state wavefunction will inevitably produce Fock states containing heavy quark pairs. The heavy quark pairs arising from perturbative gluon splitting are the extrinsic contributions associated with the substructure of the gluons; the probability for such pairs depends logarithmically on the ultraviolet resolution scale. In the case of charmonium decay to light hadrons, the extrinsic heavy quark fluctuations provide hard radiative corrections to the usual $c\bar{c}$ annihilation amplitude.

On the other hand, the intrinsic heavy quarks arise from quantum fluctuations which are multiconnected to the valence quarks of the light hadrons, and the wavefunctions describing these configurations will have maximal amplitude at minimal off-shellness and minimal invariant mass. In the case of the ρ meson the $|\bar{d}u\bar{c}c\rangle$ wavefunction will thus be maximized when the configuration of the quarks resembles that of a $|\pi J/\psi\rangle$ intermediate state, rather than a higher mass $|\bar{D}D\rangle$ state. This preference for the lowest invariant mass induces a relatively strong coupling $g_{J/\psi\rho\pi}$, *i.e.* there is a natural overlap between a $\rho\pi$ and J/ψ which facilitates the $J/\psi \rightarrow \rho\pi$ decay, as schematically illustrated in Fig. 1(b). The decay of the ψ' is naturally suppressed due to the node in its radial wavefunction, also shown schematically in Fig. 1(c). Similarly, the $|\bar{u}s\bar{c}c\rangle$ Fock component of the K^* will have a favored $J/\psi K$ configuration, allowing the $J/\psi \rightarrow K^*K$ decay to also occur by quark line rearrangement, rather than $\bar{c}c$ annihilation.

Intrinsic charm in the pion will also allow the decay $J/\psi(1S) \rightarrow \rho\pi$ to proceed

[§]In the case of the intrinsic charm or intrinsic strangeness rearrangement contribution, we only need to compute the overlap of the light-cone wavefunctions. Thus there is no extra ρ form factor suppression beyond the penalty to find intrinsic charm with large invariant mass of order of the J/ψ mass in the ρ wavefunction.

through quark rearrangement diagrams. In this case the decay can utilize configurations of the pion's $|\bar{d}u\bar{c}\rangle$ Fock state which resemble $\rho J/\psi$, where the ρ and J/ψ have opposite helicity. Again, $\psi(2S) \rightarrow \rho\pi$ decay will be suppressed because of the suppressed overlap of the radial $\bar{c}c$ wavefunctions.

The branching ratios for the $J/\psi(1S)$ and $\psi(2S)$ for many hadronic channels track fairly well with their leptonic branching ratios, as would be expected if $\bar{c}c$ annihilation into gluons and/or photons is dominant and unsuppressed by helicity selection rules. For example, the vector meson - scalar meson two-body decay channels $J/\psi(1S) \rightarrow VS$ can proceed through $\bar{c}c$ annihilation. Note that the $\bar{c}c$ rearrangement contribution to $J/\psi(1S) \rightarrow VS$ is disfavored: the J/ψ -scalar intrinsic charm excitation in a vector meson wavefunction is fairly massive, and it is thus relatively suppressed compared to the J/ψ -pseudoscalar excitations. On the other hand, tensor mesons could have an appreciable intrinsic charm content. In general, a full analysis of each exclusive decay channel will require taking into account both $\bar{c}c$ annihilation and rearrangement diagrams as well as their interference.

At first sight, the decay of J/ψ to pseudovector-scalar should be helicity suppressed in PQCD for the same reason J/ψ to pseudoscalar-vector is suppressed [7]. The argument is that there is only one Lorentz invariant, parity-conserving amplitude, and this requires that the pseudovector have helicity ± 1 . However, the light quark and antiquarks emerging from the $c\bar{c}$ annihilation into gluons have opposite helicity.

It is important to note that the pseudovector and scalar states are dominantly P -wave bound states of light quarks. The nonzero helicity of the pseudovector meson can arise from the orbital angular momentum, and thus unlike the pseudoscalar-vector channels, there is no strong PQCD suppression of the annihilation amplitude due to helicity conservation. However, the form factor suppression comparing $\psi(1S)$ and $\psi(2S)$ pseudovector-scalar decays is stronger than normal because P -wave wavefunctions vanish at the origin. Thus it is possible that both the $\bar{c}c$ annihilation and intrinsic charm rearrangement mechanisms will contribute significantly to such decay amplitudes.

It would also be interesting to compare branching ratios for the $\eta_C(1S)$ and $\eta_C(2S)$ as clues to the importance of $\eta_C(1S)$ intrinsic charm excitations in the wavefunctions of light hadrons. In principle, similar analyses can be carried out for exclusive $\Upsilon(1S)$

and $\Upsilon(2S)$ decays as clues to the intrinsic $b\bar{b}$ content of light hadrons.

Thus a systematic comparison of the various hadronic channels of heavy quarkonium could provide important constraints on the quantum numbers, magnitudes, and configurations of the intrinsic heavy quark excitations in light hadron wavefunctions.

The existence of non-OZI rearrangement mechanisms for exclusive J/ψ decay will inevitably also effect the total inclusive rate for J/ψ decay, and thus modify the value of α_s obtained by assuming that the decay amplitude is due solely to $c\bar{c}$ annihilation [17].

Acknowledgments

The authors wish to thank CERN and the organizers of the Workshop on Strange Structure of the Nucleon for their hospitality and for providing a stimulating environment which catalyzed this work. This research was supported in part by the Israel Science Foundation administered by the Israel Academy of Sciences and Humanities, and by a Grant from the G.I.F., the German-Israeli Foundation for Scientific Research and Development.

References

- [1] J. Ellis, E. Gabathuler, and M. Karliner, *Phys. Lett.* **B217**(1989)173.
- [2] J. Ellis, M. Karliner, D.E. Kharzeev, and M.G. Sapozhnikov, hep-ph/9412334, *Phys. Lett.* **B353**(1995)319.
- [3] S.J. Brodsky, P. Hoyer, C. Peterson, and N. Sakai, *Phys. Lett.* **93B**(1980)451; S.J. Brodsky, C. Peterson, and N. Sakai, *Phys. Rev.* **D23**(1981)2745; for a review, see S.J. Brodsky, *The Intrinsic Short Distance Structure of Hadrons in QCD*, SLAC-PUB-5382, invited lectures at 28-th School of Subnuclear Physics, Erice, Italy, Jul. 16-24, 1990.
- [4] M.E.B. Franklin, Ph.D. Thesis, Stanford University, 1982 (unpublished); M.E.B. Franklin *et al.*, *Phys. Rev. Lett.* **51**(1983)963; G. Trilling, *J. Phys. (Paris) Colloq.* **43**(1982)C3-81; E. Bloom, *J. Phys. (Paris) Colloq.* **43**(1982)C3-407.

- [5] Particle Data Group, *Review of Particle Physics*, *Phys. Rev.* **D54**(1996)1.
- [6] BES Collaboration, J.Z. Bai *et al.*, *Phys. Rev.* **D54**(1996)1221. This upper limit is substantially more stringent than 8.3×10^{-5} quoted in [5].
- [7] S.J. Brodsky and G.P. Lepage, *Phys. Rev.* **D24** (1981)2848.
- [8] S.J. Brodsky, G.P. Lepage, and S.F. Tuan, *Phys. Rev. Lett.* **59**(1987)621.
- [9] OBELIX Collaboration, A. Bertin *et al.*, hep-ex/9607006 and references therein and talks by K. Braune (Crystal Barrel), S.N. Prakhov (OBELIX) and A. Palano (JETSET) at the Int. Workshop *The Strange Structure of the Nucleon*, March 11-15, 1997, CERN.
- [10] S.J. Brodsky and G.P. Lepage, pp. 93-240 in *Perturbative Quantum Chromodynamics*, A.H. Mueller Ed., World Scientific, Singapore (1989).
- [11] S.J. Brodsky, W.-K. Tang, and P. Hoyer, hep-ph/9506474, *Phys. Rev.* **D52** (1995)6285.
S.J. Brodsky, P. Hoyer, A.H. Mueller, and W.-K. Tang, *Nucl. Phys.* **B369** (1992) 519;
P. Hoyer, S. J. Brodsky, pp. 238-255 in *Proc. Topical Conf. on Particle Production near Threshold*, Nashville, IN, Sep 30 – Oct 3, 1990, H. Nann and E.J. Stephenson, Eds., AIP(1991).
- [12] B.W. Harris, J. Smith, and R. Vogt, hep-ph/9508403, *Nucl. Phys.* **B461**(1996)181;
E. Hoffmann, R. Moore, *Z. Phys.* **C20**(1983) 71.
- [13] S. Kuhlmann, H.L. Lai, W.K. Tung, *HERA Events, Tevatron Jets, and Uncertainties on Quarks at Large x*, hep-ph/9704338.
- [14] J. Ellis, Y. Frishman, A. Hanany, and M. Karliner, hep-ph/9204212, *Nucl. Phys.* **B382**(1992)189.
- [15] S.S. Pinsky, *Phys. Lett.* **B236**(1990)479.

- [16] S.J. Brodsky, J.C. Collins, S.D. Ellis, J.F. Gunion, and A.H. Mueller, in Proc. Snowmass Summer Study 1984:227, R. Donaldson and J. Morfin, Eds., Fermilab 1985.
- [17] S.J. Brodsky, G.P. Lepage and P.B. Mackenzie, *Phys. Rev.* **D28**(1983)228;
M. Kobel, XXVII-th Rencontres de Moriond, 22-28 March 1992;
see also M. Schmelling, *Status of the Strong Coupling Constant*, hep-ex/9701002,
plenary talk at the XXVIII Int. Conf. on High Energy Physics, Warsaw, July
25-31, 1996

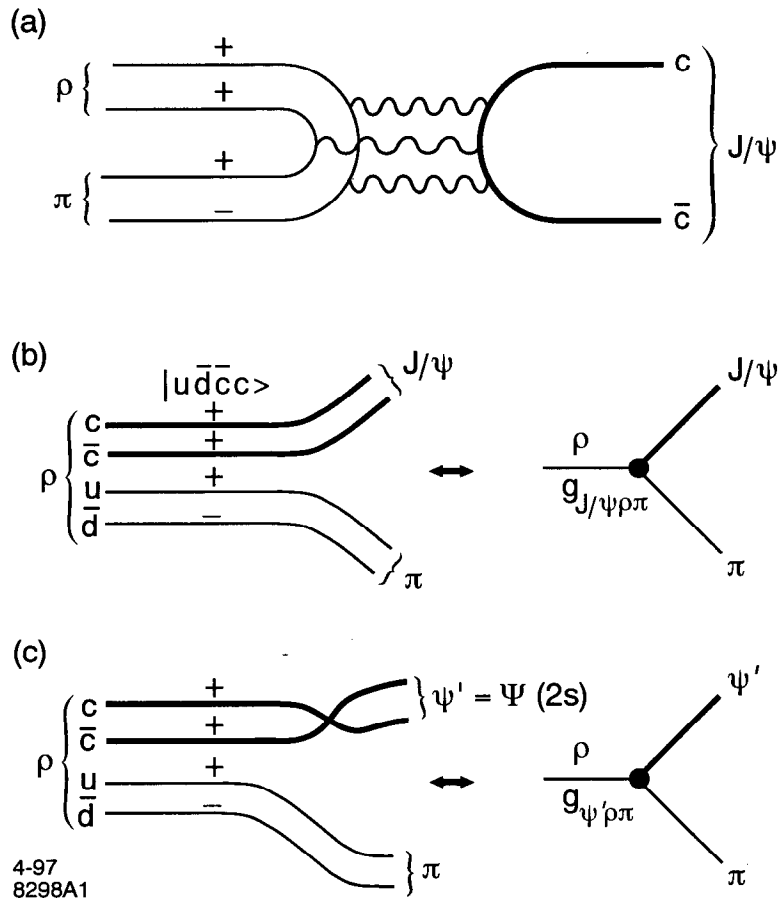

Figure 1:

(a) The decay $J/\psi(J_z = 1) \rightarrow \rho\pi$ via the standard PQCD $c\bar{c}$ annihilation mechanism. A light quark helicity-flip is required, since the ρ must be produced with helicity ± 1 .

(b) A connected quark rearrangement diagram which induces the $g_{J/\psi\rho\pi}$ coupling, via the higher Fock state of the ρ , $|u\bar{d}\bar{c}c\rangle$. The $+/-$ signs on the quark lines denote the helicities of the corresponding quarks. In the dominant intrinsic charm Fock state of the ρ , the $u\bar{d}$ and $\bar{c}c$ components of the ρ are in 0^- and 1^- states, respectively, thus generating maximal overlap with the π and J/ψ spin wavefunctions.

(c) A “twisted” connected diagram, schematically indicating the suppression of $\psi'\rho\pi$ coupling due to the mismatch between the nodeless wavefunction of the $\bar{c}c$ in the $|u\bar{d}\bar{c}c\rangle$ Fock state of the ρ and the one-node $2S$ $\bar{c}c$ wavefunction of the ψ' .