

SLAC-PUB-7393

February, 1997

Duality in Supersymmetric Yang-Mills Theory

MICHAEL E. PESKIN^a

Stanford Linear Accelerator Center

Stanford University, Stanford, California 94309 USA

ABSTRACT

These lectures provide an introduction to the behavior of strongly-coupled supersymmetric gauge theories. After a discussion of the effective Lagrangian in nonsupersymmetric and supersymmetric field theories, I analyze the qualitative behavior of the simplest illustrative models. These include supersymmetric QCD for $N_f < N_c$, in which the superpotential is generated nonperturbatively, $N = 2$ $SU(2)$ Yang-Mills theory (the Seiberg-Witten model), in which the nonperturbative behavior of the effective coupling is described geometrically, and supersymmetric QCD for N_f large, in which the theory illustrates a non-Abelian generalization of electric-magnetic duality.

to appear in the proceedings of the
1996 Theoretical Advanced Study Institute
Fields, Strings, and Duality
Boulder, Colorado, June 2-28, 1996

^aWork supported by the Department of Energy, contract DE-AC03-76SF00515.

DUALITY IN SUPERSYMMETRIC YANG-MILLS THEORY

MICHAEL E. PESKIN

*Stanford Linear Accelerator Center, Stanford University
Stanford, CA 94309, USA*

These lectures provide an introduction to the behavior of strongly-coupled supersymmetric gauge theories. After a discussion of the effective Lagrangian in nonsupersymmetric and supersymmetric field theories, I analyze the qualitative behavior of the simplest illustrative models. These include supersymmetric QCD for $N_f < N_c$, in which the superpotential is generated nonperturbatively, $N = 2$ $SU(2)$ Yang-Mills theory (the Seiberg-Witten model), in which the nonperturbative behavior of the effective coupling is described geometrically, and supersymmetric QCD for N_f large, in which the theory illustrates a non-Abelian generalization of electric-magnetic duality.

1 Introduction

Despite the recent dramatic progress in string theory, our understanding of string phenomena is still grounded in our understanding of quantum field theory. Though string theory has magical properties that might make ordinary local quantum field theory feel drab and envious, field theory often allows a tactile understanding of issues that string theory still leaves mysterious. So it is useful to look for field theory realizations of the phenomena of string theory, in order to find a more complete understanding of these phenomena.

In fact, much of the impetus for the recent developments in string theory has come from new discoveries in field theory. For the past several years, Seiberg has led an effort to exploit the special simplifications of supersymmetric field theory to discover the behavior of these theories in the region of strong coupling. His investigations led to many wonderful realizations about these theories. In particular, he discovered that many cases have remarkable nontrivial dual descriptions.

In addition, however one considers the relative role of field theory and string theory, it is certainly true that physics at distances well below the Planck scale is described by a local quantum field theory. If, as phenomenological studies suggest, this field theory is approximately supersymmetric, then the basic building blocks for any theory of elementary particle physics are supersymmetric field theories, and, most probably, supersymmetric Yang-Mills theories. Any special properties of these systems could well be reflected directly in the physics of elementary particles.

Thus, we have three reasons to explore the physics of supersymmetric

Yang-Mills theory, for its relevance to the mathematical physics of fields, for its relevance to the mathematical physics of strings, and for its own direct application to theories of Nature. But the best reason to explore this subject is that it justifies itself through its beauty and richness. In these lectures, I will provide an introduction to the physics of supersymmetric Yang-Mills theory, and I will try to capture at least a bit of the underlying beauty.

These lectures will analyze the physics of supersymmetric Yang-Mills theories through the analysis of effective Lagrangians constructed to describe their low-energy dynamics. In Section 2, I will discuss the general idea of an effective Lagrangian description of a strongly-coupled quantum field theory. In Section 3, I will discuss the special properties of supersymmetric effective Lagrangians and, in the process, introduce the most important tools that we will use in our study. In Section 4, I will give a first illustration of these tools by describing the Affleck-Dine-Seiberg picture¹ of the dynamics in the supersymmetric generalization of QCD.

In Section 5, I will present the Seiberg-Witten solution^{2,3} of the $SU(2)$ Yang-Mills theory with $N = 2$ supersymmetry. In this solution, magnetic monopoles which appear as solitons in the weak-coupling analysis of the theory play a crucial dynamical role at strong coupling. The dynamics of this theory illustrates a role reversal of electrically and magnetically charged fields which illustrates electric-magnetic duality in a quite unusual context. This analysis, which showed how solitons could take on the dynamical properties of quantum particles, has become an important touchstone in many aspects of field theory and string theory duality, and in mathematical studies which make use of concepts of quantum field theory. In Section 6, I will present some generalizations of the Seiberg-Witten theory which illustrate additional novel effects that may be found in these models.

In Section 7, I will return to supersymmetric QCD and consider this theory for the case of many quark and squark flavors. In this case, Seiberg⁴ has given evidence for a new type of dual description, which he calls 'non-Abelian electric-magnetic duality'. I will explain this duality and its relation to new nontrivial renormalization group fixed points in four dimensions. Finally, in Section 8, I will discuss some generalizations of non-Abelian duality and the connection of this idea to the Abelian electric-magnetic duality of the Seiberg-Witten model.

2 General Principles

As I have noted in the introduction, Yang-Mills theories are the basic building-blocks for models of the fundamental interactions. Our current understanding of the strong, weak, and electromagnetic interactions rests on our knowledge of

how the specific Yang-Mills theories which appear in Nature behave. In fact, among the most difficult steps in the creation of the present 'standard model' of particle physics was the realization that Yang-Mills theory can reproduce the observed qualitative features of the major forces of Nature.

In trying to create theories of Nature at shorter distances, we can try to use again the qualitative features that we have already found in Yang-Mills theory or we can discover new ways in which these theories can behave. The most basic information we can give about the qualitative behavior of a quantum field theory is the manner in which its symmetries are realized in the vacuum state. So the general question that we will be interested in is the following: Given a Yang-Mills theory with gauge group G_c and global symmetry G , how are G_c and G realized in the vacuum state of the theory?

2.1 A familiar example

In this section, I will give a specific example of an answer to this question and a survey of the possible choices for this qualitative behavior. The example I would like to consider is an $SU(3)$ gauge theory with three flavors of massless fermions. The Lagrangian of the theory is

$$\mathcal{L} = -\frac{1}{4} (F_{\mu\nu}^a)^2 + \bar{q}_L^f i \not{D} q_L^f + \bar{q}_R^f i \not{D} q_R^f, \quad (1)$$

for $f = 1, 2, 3$. The gauge symmetry is $G_c = SU(3)$. At the classical level, the global symmetry is $U(3) \times U(3)$, separate general unitary transformations on q_L^f and q_R^f . However, the $U(1)$ transformation

$$q_L \rightarrow e^{i\alpha} q_L \quad q_R \rightarrow e^{-i\alpha} q_R \quad (2)$$

is spoiled by the anomaly, so that the global symmetry of the quantum theory is $G = SU(3) \times SU(3) \times U(1)$.

This example is, of course, QCD, the correct theory of the strong interactions. I have only made the idealization of ignoring the masses of the light quarks u , d , and s . For this case, there is an enormous amount of evidence from experiment, theoretical considerations, and simulations which leads to a definite picture of the realization of G_c and G . For G_c , we observe experimentally the permanent confinement of quarks in to color-singlet bound states. This property is also seen in studies of the strong-coupling limit of QCD on a lattice⁵, and in lattice simulations of QCD in the region of intermediate coupling.⁶ The theory is asymptotically free at short distances, and the lattice results show that there is no barrier to the coupling becoming strong at large distances.

For G , the $SU(3) \times U(1)$ subgroup is observed as a classification symmetry of hadrons; $SU(3)$ gives the flavor quantum numbers and the $U(1)$ charge is baryon number. The remaining generators of G must be broken in some way. In fact, it makes sense intuitively that at strong coupling quarks and antiquarks should bind into pairs, and that the vacuum would be filled by a condensate of these pairs. This intuition can be supported by explicit calculations in various approximation schemes.⁷ To connect this intuition with experimental observations, we have to take a few further steps.

A quark-antiquark pair condensate is characterized by a vacuum expectation value of a scalar color singlet quark bilinear $\bar{q}_L^f q_R^{f'}$. The simplest form that this expectation value could take is

$$\langle \bar{q}_L^f q_R^{f'} \rangle = \Delta \delta^{ff'} . \quad (3)$$

Since separate $SU(3)$ rotations of q_L^f and $q_R^{f'}$ do not leave this form invariant, (3) signals the spontaneous breaking of G , in the pattern

$$SU(3) \times SU(3) \times U(1) \rightarrow SU(3) \times U(1) . \quad (4)$$

Eight global symmetries are broken, and so eight Goldstone bosons must appear. These belong to the adjoint representation of the unbroken $SU(3)$. Phenomenologically, these bosons can be identified with the eight exceptionally light pseudoscalar mesons π , K , \bar{K} , η .

In fact, we now have enough information to build a quantitative theory of the couplings of the pseudoscalar mesons. An $SU(3)$ rotation of the q_L^f or $q_R^{f'}$ separately converts the vacuum expectation value (3) into

$$\langle \bar{q}_L^f q_R^{f'} \rangle = \Delta U^{ff'} , \quad (5)$$

where U is an $SU(3)$ matrix. Thus, the model has a manifold of vacuum states which is isomorphic to the group $SU(3)$. The low energy degrees of freedom of the theory should correspond to slow point-to-point changes in the vacuum orientation. We can parametrize these by a field $U(x)$ which gives the local vacuum orientation at each point. The $U(1)$ symmetry corresponding to baryon number leaves $U(x)$ invariant. An $SU(3) \times SU(3)$ transformation acts on $U(x)$ by

$$U(x) \rightarrow \Lambda_L^\dagger U(x) \Lambda_R , \quad (6)$$

where Λ_L, Λ_R are independent 3×3 unitary matrices.

The dynamics of the model should be described by a Lagrangian written in terms of the variables $U(x)$ which is invariant to the full G symmetry. To

construct the possible terms in this Lagrangian, we can consider the terms with each possible number of derivatives. There are no terms without derivatives, since any G -invariant can contain $U(x)$ only in the combination $U^\dagger U = 1$. There is a unique term with two derivatives, and additional possible terms with higher derivatives:

$$\mathcal{L} = f_\pi^2 \text{tr} [\partial_\mu U^\dagger \partial^\mu U] + \kappa \text{tr} [\partial_\mu U^\dagger \partial^\mu U \partial_\nu U^\dagger \partial^\nu U] + \dots \quad (7)$$

Since there are no nonderivative terms, the eight degrees of freedom in $U(x)$ are massless, as required by Goldstone's theorem. At sufficiently low energies, the interactions of these eight fields should be well described by the term with two derivatives. The corrections due to four- and higher-derivative terms are proportional to powers of k^2/M^2 , where M is an intrinsic mass scale of the theory. Thus, we find definite predictions for the low-energy scattering amplitudes of the mesons, in terms of a single parameter f_π .

In principle, the Lagrangian (7) could be derived starting from the QCD Lagrangian (1) by integrating out the high-momentum degrees of freedom. However, this would be a very difficult analysis that would need essential information about the strong-coupling region of the theory. On the other hand, we know in advance that the final answer must have the form (7), since this is the most general Lagrangian depending on $U(x)$ which has the symmetries of the original problem. When combined with terms representing the weak G symmetry breaking due to nonzero quark masses, the Lagrangian (7) in fact does a good job of representing the low-energy interactions of the pseudoscalar mesons.^{8,9,10}

For QCD, then, all of the pieces of the story fit together neatly. Basic theoretical considerations, the results of numerical simulations, and experimental observations all reinforce this qualitative picture of the physics of the QCD Lagrangian. But what is the situation for other possible Yang-Mills theories? Need there be confinement of the gauge charges? Could we find another pattern of global symmetry breaking? Does the low-energy spectrum consist only of Goldstone bosons, or can it contain additional bosons and fermions?

The example of QCD demonstrates that, once one has a definite qualitative picture of the dynamics in a Yang-Mills theory, much more can be learned by writing the *effective Lagrangian* which contains the degrees of freedom relevant at low energies and gives the most general form of their interaction consistent with the symmetries of the problem. But, in nonsupersymmetric gauge theories, there are very few methods known to constrain the qualitative pattern of symmetry-breaking.

This is a place that supersymmetry can add powerfully to our technology. We will see that, in the case of supersymmetric Yang-Mills theory, the

effective Lagrangian obeys strong constraints which can test the consistency of different schemes of global symmetry breaking. In these lectures, the construction of effective Lagrangians will be one of our major tools in working out the qualitative behavior of a variety of supersymmetric theories.

2.2 Phases of gauge theories

Before going on to supersymmetric theories, I must review one more set of insights gained from nonsupersymmetric gauge theories, which gives the possible patterns in which the gauge symmetry can be realized.

The original gauge symmetry G_c could be completely spontaneously broken. Alternatively, the vector bosons could mediate long-ranged interactions. These might give rise either to potentials associated with vector boson exchange or to confinement of the gauge charge. It is common to characterize these various types of behavior as possible *phases* in which the gauge symmetry can be realized:

- Higgs phase: spontaneous breaking of G_c , all vector bosons obtain mass.
- Coulomb phase: G_c vector bosons remain massless and mediate $1/r$ interactions.
- Wilson phase: G_c color sources are permanently bound into G_s singlets.

It is possible to have intermediate situations, for example, a gauge theory spontaneously broken from G_c to a subgroup H_c which is then confined. In such situations, I will describe the phase by the behavior of the subgroup that survives to the lowest energy. I should also note that the presence of a Coulomb phase is not unique to electrodynamics. A Yang-Mills theory with sufficiently many fermions that it is no longer asymptotically free gives a long-ranged potential between color charges of the form $1/r$ times a coefficient which decreases slowly as the logarithm of the separation.

The relation of these phases is especially well understood for the Abelian case $G_c = U(1)$. There, the Coulomb phase can contain both electric and magnetic charges, with dual coupling strengths. A vacuum expectation value for an *electrically* charged field takes us to the Higgs phase. This phase has solitons which have the form of magnetic flux tubes. Dually, the appearance of a vacuum expectation value for a *magnetically* charged field gives a phase with electric flux tubes which permanently confine electric charge.^{11,12} This is a Wilson phase. In Abelian lattice gauge theories, one can make this duality manifest.¹³ Certain of these theories show all three phases, with two second-order phase transitions as a function of the coupling strength.^{14,15} Such distinct phases can also arise in non-Abelian gauge theories.

On the other hand, the relation of the Higgs and confinement phases in the non-Abelian case is often more subtle. In many examples, there is no invariant distinction between the Higgs and confinement phases and one can, as a matter of principle, move continuously from one to the other. Fradkin and Shenker made this possibility concrete by exhibiting lattice gauge theory models in which it was possible to prove that these phases were continuous connected.¹⁶

Here is an interesting illustrative example.¹⁷ Consider an $SU(2)$ gauge theory like the standard electroweak theory, with a Higgs scalar doublet ϕ , an $SU(2)$ singlet right-handed fermion e_R , and a left-handed fermion doublet $L = (\nu_L, e_L)$. In the realization of the $SU(2)$ gauge symmetry which is standard in electroweak theory, the electron obtains a mass through the interaction

$$\mathcal{L}_m = \lambda \bar{L} \cdot \phi e_R + h.c. \quad (8)$$

The scalar ϕ receives the vacuum expectation value

$$\langle \phi \rangle = \frac{1}{\sqrt{2}} \begin{pmatrix} 0 \\ v \end{pmatrix}, \quad (9)$$

which breaks the $SU(2)$ gauge symmetry completely, giving mass to all three vector bosons. Inserting (9) into (8), we find a mass for the electron

$$m_e = \frac{\lambda v}{\sqrt{2}}, \quad (10)$$

while ν_L remains massless.

Now consider what would happen if the theory were realized with $SU(2)$ color confinement. Again, there are no massless gauge bosons. The fermions and the Higgs bosons would bind into the $SU(2)$ singlet combinations

$$E_L = \phi^\dagger \cdot L \quad N_L = \epsilon_{ab} \phi_a L_b \quad e_R. \quad (11)$$

The coupling (8) then takes the form of a mass term for the color-singlet combinations E_L and e_R ,

$$\mathcal{L}_m = m \bar{E}_L e_R + h.c. \quad (12)$$

In this way, E_L and e_R pair and become massive, while N_L remains massless.

In this example, the qualitative form of the spectrum is the same in the two cases, and in fact there is no gauge-invariant expectation value that distinguishes them. Of course, the two situations are quantitatively distinguishable.

For example, because the E_L is composite, its pair-production would be suppressed by a form factor which is not observed in high-energy experiments. Thus, we know experimentally that the electroweak interactions are realized in a Higgs phase and not a Wilson phase. However, this example indicates the possibility that, by adjusting some parameters of a gauge theory, we can move continuously from one type of phase to the other. Such transitions will occur frequently in the examples that I will discuss later. By trying to visualize how these transformations occur, one can acquire the flexibility of intuition needed to understand the global features of these models.

3 Supersymmetric Effective Lagrangians

In the previous section, I introduced the general question of the realization of symmetry in a Yang-Mills theory. I discussed the utility of constructing an effective Lagrangian as a way of analyzing the qualitative features of the model in the regime of strong coupling. So far, all of my remarks apply equally well to conventional and supersymmetric quantum field theory. In this section, I would like to discuss the additional restrictions and tools for analysis that appear in the supersymmetric case.

3.1 *The general supersymmetric Lagrangian*

In these lectures, I will only discuss models with global supersymmetry. I will be concerned with models that, at the fundamental level, are renormalizable gauge theories. However, when we describe these models by writing effective Lagrangians, we will often be interested in models which are not renormalizable and may contain no gauge interactions. For the nonsupersymmetric case, (7) provides an example. Thus, it is best to begin by writing down the most general form of a supersymmetric Lagrangian and understanding what additional restrictions supersymmetry implies.

The basic ingredients for the construction of supersymmetric field theories are chiral superfields Φ^i , antichiral superfields $\Phi^{\dagger i}$, and vector superfields V^a . For simplicity, I will represent with vector fields only the subgroup of the gauge group H_c which is realized manifestly. Then the V^a belong to the adjoint representation of H_c . The Φ^i belong to some representation r of H_c ; call the generators of H_c in this representation t^a . Methods for the construction of Lagrangians for these fields are described in the lectures of Lykken.¹⁸ The most general Lagrangian for the Φ^i and V^a with at most two derivatives takes

the form

$$\begin{aligned} \mathcal{L} = & \int d^4\theta K(\Phi^\dagger, e^{V\cdot}\Phi) + \left(\frac{-i}{16\pi}\right) \int d^2\theta \tau(\Phi) \mathcal{W}^{\alpha a} \mathcal{W}_{\alpha a} + h.c. \\ & + \int d^2\theta W(\Phi) + h.c. \end{aligned} \quad (13)$$

The first term of (13) is a nonlinear sigma model for the fields Φ^i , that is, a nonlinear model in which the bosonic components of Φ^i may be thought of as coordinates on a manifold. This is a complex manifold with metric derived from the Kähler potential $K(\Phi^\dagger, \Phi)$. Thus, the terms involving the bosonic components of Φ only, with two derivatives, are

$$\mathcal{L} = g_{ij} \partial_\mu \Phi^{\dagger i} \partial^\mu \Phi^j + \dots \quad (14)$$

where

$$g_{ij} = \frac{\partial^2 K}{\partial \Phi^{\dagger i} \partial \Phi^j} . \quad (15)$$

The second term in (13) is the kinetic term for the gauge fields. The superfield $\mathcal{W}^{\alpha a}$ contains as its components the gaugino fields and the gauge field strengths. The coefficient of this term should be proportional to $(1/g^2)$. More generally, τ is the natural combination of the gauge coupling and the θ parameter,

$$\tau = \left(\frac{\theta}{2\pi} + i \frac{4\pi}{g^2} \right) . \quad (16)$$

In an effective Lagrangian, τ represents a large-distance coupling, which differs from the short-distance coupling by some renormalization effects. Since these renormalizations can depend on the nature of the vacuum state, τ can depend on the values of chiral superfields that indicate which vacuum has been chosen. If the gauge group H_c is not simple, τ should be generalized to a matrix τ^{ab} .

The last terms in (13) contain the superpotential $W(\Phi)$. This term leads to the nonderivative interactions of the chiral superfields. An important property of the superpotential is its nonrenormalization: In any order of perturbation theory, the superpotential can be modified only by field rescalings. In particular, if the superpotential is zero in the underlying theory at short distances, a superpotential can be generated in the effective Lagrangian only by nonperturbative effects.¹⁹

In the Lagrangian (13), the Kähler potential K can be a general real-valued function of Φ and Φ^\dagger . However, the coefficient functions which appear under chiral fermion integrals, $\tau(\Phi)$ and $W(\Phi)$, must be *holomorphic* functions of the chiral fields. If these functions carry any dependence on Φ^\dagger , the Lagrangian

will not be supersymmetric. This restriction is apparently straightforward, but it will turn out to be a very powerful constraint on the effective Lagrangian.

I should note an important subtlety which is contained in this statement. The transition from a fundamental Lagrangian to an effective Lagrangian involves integrating out high-momentum degrees of freedom. Alternatively, we might just integrate out all of the degrees of freedom and calculate the Green's functions of the original theory. The generating functional of Green's functions is the *effective action* Γ , which is often interpreted as a sort of effective Lagrangian. However, Γ typically does not have the form of a supersymmetric Lagrangian with holomorphic coefficients.

An important example arises in the renormalization of gauge couplings. Let g^2 be the short-distance coupling defined at a large scale M . Integrating out a charged field with vacuum expectation value Φ will produce a renormalized gauge coupling. If we compute this coupling using the one-loop β function only,

$$\beta(g) = -\frac{b_0}{(4\pi)^2} g^3, \quad (17)$$

we find a holomorphic result of the form

$$\tau_{\text{eff}} = \frac{4\pi i}{g^2} - \frac{ib_0}{2\pi} \log \frac{M}{\Phi}. \quad (18)$$

However, the result of integrating the two-loop renormalization group equation involves $\log \log(|\Phi|^2)$ and is not properly holomorphic. Shifman and Vainshtein have explained how to reconcile this result with the supersymmetry of the effective action.^{21,22} Integrating out only high-momentum degrees of freedom leads to the result (18). This gives the coefficient of the gauge kinetic term in the effective Lagrangian. To emphasize that only high-momentum degrees of freedom are considered, they call this result the 'Wilsonian effective Lagrangian'. If one continues to integrate out degrees of freedom down to zero momentum, one finds the additional terms in the effective action which convert the coefficient of $(F_{\mu\nu}^a)^2$ to the solution of the two-loop renormalization group equation. In these lectures, I will typically be carrying out manipulations at the level of the Wilsonian effective action, and so the one-loop β functions will be not only sufficient but exact.

3.2 Conditions for the vacuum state

Once we have written a supersymmetric effective Lagrangian in the form (13), we can try to find the vacuum state of the theory. In supersymmetric theories, the energy of any state satisfies $\langle H \rangle \geq 0$, where equality holds if the state is

annihilated by the supersymmetry generators. Thus, if a supersymmetric state exists, it will be a vacuum state of zero energy.

To find the vacuum state of from the effective Lagrangian, we minimize the potential energy. The Lagrangian (13) leads to a potential energy of the form

$$V = F_i^\dagger g^{ij} F_j + \frac{1}{2} g^2 (D^a)^2 \quad (19)$$

where g is the coupling constant defined by (16), g^{ij} is the inverse of the metric (15), and the Lagrange multiplier fields F_j and D^a are given by

$$\begin{aligned} F_j &= \frac{\partial}{\partial \Phi^j} W \\ D^a &= \sum_i \Phi^\dagger t^a \Phi^i, \end{aligned} \quad (20)$$

where t^a represents the gauge group generators on Φ . F_j and D^a transform nontrivially under supersymmetry, in such a way that the conditions

$$\langle F_j \rangle \neq 0 \quad \text{or} \quad \langle D^a \rangle \neq 0 \quad (21)$$

signal the breaking of supersymmetry. On the other hand, if supersymmetry is exact, the formula (19) gives $V = 0$.

The conditions $F_j = 0$ and $D^a = 0$ are called, respectively, ' F -flatness' and ' D -flatness'. Typically, these conditions can be satisfied simultaneously, leading to a supersymmetric vacuum state. For example, if W is a polynomial in unconstrained fields Φ^i , the conditions

$$\frac{\partial W}{\partial \Phi^i} = 0 \quad i = 1, \dots, n \quad (22)$$

are n polynomial equations in n unknowns, to be solved over the complex domain. A solution will exist unless we are in an exceptional case. One way to arrange such an exceptional case is to choose W in such a way that, for some particular value of i , Φ^i does not appear in (22). Then some remaining Φ^i is doubly constrained. This is how the O'Raifeartaigh model of supersymmetry breaking works.²³

The conditions $F_j = 0$ are holomorphic in fields. The D -flatness conditions are not holomorphic, but the solutions to $D^a = 0$ can be parametrized holomorphically. The reason for this is that the fundamental gauge symmetry of a supersymmetric gauge theory is

$$\Phi \rightarrow e^{i\alpha \cdot t} \Phi \quad (23)$$

where α is a chiral superfield. The bosonic part of α is thus a complex parameter. The F -flatness conditions are invariant under this complex extension of the gauge group. The D -flatness condition may be thought of as a gauge-fixing term which breaks this complex gauge symmetry down to the actual gauge group G_c .²⁴ That is, fixing the gauge symmetry G_c and imposing of the conditions $D^a = 0$ is equivalent to fixing the complex extension of G_c . Then the solution of the $D^a = 0$ conditions are described by gauge-invariant combinations of holomorphic fields. Luty and Taylor²⁴ have shown, further, that it is possible to parametrize the space of solutions of the D -flatness conditions simply by gauge-invariant polynomials. We will see examples in Section 4 in which both descriptions of the D -flat configurations, that in terms of expectation values of the fundamental fields, and that in terms of the gauge-invariant polynomials, are useful.

3.3 Consequences of holomorphicity

The holomorphic structures involving the coupling constant and the superpotential have some additional consequences that I will make use of in my analysis. Let me discuss three of these points here.

First, the description of supersymmetric Lagrangians in superspace naturally suggests that the complex rotation of the fermionic coordinate θ^α should be a symmetry,

$$\theta \rightarrow e^{-i\alpha} \theta . \quad (24)$$

This transformation, called ‘ R symmetry’, is realized on the component fields as chiral rotations of the fermionic fields of the model. If we denote the fermionic components of chiral superfields by ψ^i and the gaugino fields by λ^a , then the transformation (24) can be written alternatively as

$$\psi^i \rightarrow e^{-i\alpha} \psi^i \quad \lambda^a \rightarrow e^{i\alpha} \lambda^a . \quad (25)$$

R -symmetry may be broken if the superpotential does not transform correctly. Since the term in the Lagrangian following from the superpotential is

$$\mathcal{L}_W = \int d^2\theta W = (\text{coefficient of } \theta^2 \text{ in } W) , \quad (26)$$

the superpotential should have charge 2 under R ,

$$W \rightarrow e^{+2i\alpha} W . \quad (27)$$

If the fundamental theory has R symmetry, the effective Lagrangian should respect this, and so the superpotential of the effective Lagrangian should have R -charge equal to 2.

It often happens that the ‘canonical’ R symmetry just described is anomalous. In that case, it is often possible to form a non-anomalous $U(1)$ symmetry by combining the canonical R symmetry with some global $U(1)$ transformation that acts on chiral multiplets. If the anomaly-free R transformation is to be a symmetry, the superpotential must have charge 2 under this modified transformation. In the following sections, when I apply R symmetry, I will state explicitly whether I am discussing the canonical or the anomaly-free R transformation.

The second of these consequences concerns the symmetry-breaking dynamics of gauginos. Because the gauginos of supersymmetric Yang-Mills theories are massless, strongly interacting fermions, it will be interesting to ask whether these particles undergo pair condensation like the quarks in QCD. Holomorphicity gives us a useful tool to examine this question.

The gaugino condensate analogous to (3) is

$$\langle \lambda^{\alpha a} \lambda_{\alpha}^a \rangle . \quad (28)$$

The fermion bilinear in (28) is also the scalar component of the superfield $\mathcal{W}^{\alpha a} \mathcal{W}_{\alpha}^a$. This means that we can extract the expectation value of this operator by differentiating the Lagrangian (13) with respect to F_{τ} , the F component of τ . The fundamental definition of the operator is given by differentiating with respect to the F term of the short-distance coupling constant $\tau_0 = 4\pi i/g^2$. However, according to (18), the effective gauge coupling τ_{eff} is related to the short-distance coupling τ by an additive term, so we could equally well simply differentiate with respect to the F terms of τ_{eff} . In any event, we have

$$\langle \lambda^{\alpha a} \lambda_{\alpha}^a \rangle = 16\pi \frac{\partial}{\partial F_{\tau}} \log Z, \quad \text{where } Z = \int e^{i \int \mathcal{L}} . \quad (29)$$

If we integrate out the gauge fields and describe the theory using an effective Lagrangian with chiral fields only, we can still recover the value of the gaugino condensate through the dependence of the effective superpotential W_{eff} on τ ,

$$\langle \lambda \lambda \rangle = 16\pi i \frac{\partial}{\partial F_{\tau}} \int d^2\theta W_{\text{eff}}(\tau, \phi) = 16\pi i \frac{\partial}{\partial \tau} W_{\text{eff}}(\tau, \phi) . \quad (30)$$

Finally, it is interesting to think about the relation between the effective Lagrangians of related supersymmetric models. An example we will often encounter is the relation between a Yang-Mills theory with $(n+1)$ matter flavors to that with n flavors. We can obtain the second of these theories from the first by adding a mass term for the $(n+1)$ st flavor and then taking this mass to be large.

The result of this procedure on the effective superpotential is very simple to analyze. Typically, if the chiral field Φ_{n+1} is not yet integrated out, the mass operator for this field in the effective Lagrangian will be simply the original mass term for this field. Then, if the theory with $(n + 1)$ massless flavors has superpotential W_{eff} , the superpotential with the mass perturbation will be

$$W_{\text{eff}}(\Phi) + m\Phi_{n+1}^2 . \quad (31)$$

We can then solve the F -flatness conditions which involve m and use these to eliminate the field Φ_{n+1} from the effective Lagrangian. This procedure generates a new holomorphic effective superpotential from the original one.

I will refer to the relation of these two superpotentials as ‘holomorphic decoupling’. If we have the exact form of the effective superpotential for some number of flavors n , decoupling allows us to compute the effective superpotentials explicitly for any smaller number of flavors. Even more remarkably, holomorphic decoupling also turns out to be a powerful tool for determining the effective superpotentials in model with a larger number of flavors, since it provides a stringent consistency condition on any proposed superpotential for these models.

4 Supersymmetric QCD

As a first example for the application of these methods, I would like to consider the supersymmetric generalization of QCD, $SU(N_c)$ gauge theory with N_f flavors of quark superfields in the fundamental representation of the gauge group. At least for the case of a small number of flavors, this theory was analyzed many years ago by Veneziano, Taylor, and Yankielowicz²⁶ and by Affleck, Dine, and Seiberg.¹ Naively, one might expect the same behavior found in ordinary QCD—chiral symmetry breaking caused by pair condensation of the quarks. Instead, we will find many surprises.

4.1 Lagrangian and symmetries

Let me first set up some basic notation for this theory. The N_f flavors of quarks can be described as N_f left-handed fermions in the $(N_c + \overline{N}_c)$ representation of the gauge group. These belong to chiral supermultiplets that I will call Q_i and \overline{Q}_i , $i = 1, \dots, N_f$. Note that the bar refers to a chiral superfield in the \overline{N}_c representation, while an antichiral superfield will be denoted by a dagger. I will use the symbol Q_i to denote both the superfield and its scalar component (with the precise meaning hopefully evident from context) and denote the fermionic components of Q_i , \overline{Q}_i by ψ_{Q_i} , $\psi_{\overline{Q}_i}$.

The Lagrangian of supersymmetric QCD is

$$\mathcal{L} = \int d^4\theta \left(Q_i^\dagger e^V Q_i + \bar{Q}_i e^V \bar{Q}_i^\dagger \right) - \frac{i}{16\pi} \int d^2\theta \tau W^{\alpha a} W_\alpha^a + h.c. , \quad (32)$$

$i = 1, \dots, N_f$, with no superpotential. At the classical level, this theory has the R symmetry (24). In the quantum theory this symmetry is anomalous, though it will still be useful to us, as we will see in a moment. On the other hand, the R symmetry can be combined with the anomalous $U(1)$ flavor symmetry to form an anomaly free R symmetry. The full global symmetry of the model is then

$$G = SU(N_f) \times SU(N_f) \times U_B(1) \times U_R(1) , \quad (33)$$

where the first $U(1)$ factor is proportional to baryon number and the second is the anomaly-free R symmetry. I will define the chiral multiplets Q_i to have $U_B(1)$ charge $B = +1$; the chiral multiplets \bar{Q}_i , whose fermionic components are left-handed antiquarks, will have $B = -1$.

If we wish to work with the anomalous R symmetry, we must take into account the effect of the anomaly. To do this, note that the chiral rotation of a left-handed fermion field

$$\psi \rightarrow e^{i\alpha} \psi \quad (34)$$

changes the measure of integration over ψ in such a way as to shift the θ parameter of the Yang-Mills theory by

$$\theta \rightarrow \theta - n\alpha \quad (35)$$

where n is the coefficient of the anomaly term in the conservation law for the corresponding chiral current. (Equivalently, n is the number of zero modes of ψ in a one-instanton solution of the Yang-Mills equations.) Thus, an anomalous chiral symmetry can be combined with a transformation of θ or τ to give a symmetry of the theory.

A supersymmetric Yang-Mills theory with gauge group G_c and chiral superfields in the representations r_i has a one-loop β function of the form (17), with

$$b_0 = 3C_2(G_c) - \sum_i C(r_i) , \quad (36)$$

where $C_2(r)1 = (t^a t^a)_r$ is the quadratic Casimir operator and $C(r)\delta^{ab} = \text{tr}_r[t^a t^b]$, and G_c denotes the adjoint representation. In the same notation, the anomaly coefficient n for fermions in the representation r is given by

$$n = 2C(r) = \begin{cases} 1 & r = N_c \text{ or } \bar{N}_c \text{ of } SU(N_c) \\ 2N_c & r = \text{adjoint of } SU(N_c) \end{cases} \quad (37)$$

In the case of supersymmetric QCD, the formula for the β function becomes

$$b_0 = 3N_c - N_f . \quad (38)$$

If the fundamental coupling constant g^2 is defined at the large mass scale M , the effective running coupling constant of the theory is given by

$$\frac{4\pi}{g^2}(Q) = \frac{4\pi i}{g^2} - \frac{3N_c - N_f}{2\pi} \log \frac{M}{Q} . \quad (39)$$

It is convenient to define Λ to be the scale at which this expression formally diverges,

$$\Lambda^{b_0} = M^{b_0} e^{-8\pi^2/g^2} = M^{b_0} e^{2\pi i \tau} . \quad (40)$$

Note that, in any particular perturbative scheme for defining g^2 , such as \overline{MS} or \overline{DR} , there may be a scheme-dependent constant added to the right-hand side of (39), which generates an overall constant rescaling of Λ . I will ignore these constants, since they can be absorbed by a redefinition of M . However, to compare exact results for supersymmetric Yang-Mills theory to explicit perturbative or instanton calculations, it is necessary to keep track of these terms. A careful treatment is given in²⁷.

4.2 $N_f = 0$

Let us begin by considering the pure supersymmetric Yang-Mills theory, the case $N_f = 0$. The Lagrangian of this theory is written in terms of component fields as

$$\mathcal{L} = -\frac{1}{4g^2} (F_{\mu\nu}^a)^2 + \frac{1}{g^2} \bar{\lambda}^a i \not{D} \lambda^a + \frac{i\theta}{32\pi^2} F_{\mu\nu}^a \tilde{F}^{a\mu\nu} . \quad (41)$$

This Lagrangian looks just like that of ordinary QCD, but with the massless quarks replaced by one flavor in the adjoint representation of the gauge group. In (41), the gaugino λ^a is a left-handed field, but this is not an essential difference because λ^a belongs to a real representation of G_c and thus can have a gauge-invariant mass term. It is very tempting to conjecture that this theory behaves exactly like QCD: The gauge coupling becomes strong and confines color, the gauginos condense into the vacuum in pairs and break the chiral symmetry.²⁵

To analyze this theory, we should first understand its global symmetries. Because there are no quark flavors, it is not possible to build an anomaly-free R symmetry in this case. However, a discrete subgroup of the canonical R symmetry is left unbroken. One way to see this is to note that, according to

(35), a chiral rotation of the gaugino field becomes a symmetry if we combine it with a shift of the θ parameter

$$\theta \rightarrow \theta + 2N_c\alpha, \quad \text{or} \quad \tau \rightarrow \tau + \frac{2N_c}{2\pi}\alpha. \quad (42)$$

Since the physics of Yang-Mills theory is periodic in θ with period 2π , no compensation is necessary if α is a multiple of $2\pi/2N_c$. Thus, a Z_{2N_c} subgroup of the original R symmetry survives as a symmetry of the quantum theory.

On the other hand, it is often appropriate to think of τ as an adjustable background superfield. In string theory, τ is proportional to the dilaton superfield S . If the pure Yang-Mills theory is derived by integrating out fields which are massive due to the vacuum expectation value of some chiral superfield Φ , the effective coupling τ will be a function of Φ . If we take this point of view that τ may be treated as a background superfield, then the supersymmetric Yang-Mills theory should be invariant under the full continuous R -symmetry combined with the shift of this superfield given in (42).

This statement has an interesting consequence. Under our hypothesis, the pure supersymmetric Yang-Mills theory has no massless particles. The gluons and gluinos combine into massive color-singlet bound states gg , $\lambda\lambda$, and $g\lambda$. Thus, the low-energy effective Lagrangian of the theory contains only the background superfield τ . In principle, this Lagrangian should have a superpotential which is a function of τ . The requirement that the superpotential should have R charge 2 specifies its form uniquely:

$$W_{\text{eff}} = c M^3 e^{2\pi i\tau/N_c}, \quad (43)$$

where c is a constant and I have supplied factors of the large scale M to give W_{eff} the correct mass dimension. Given (43), we can use (30) to compute the gaugino condensate,

$$\langle\lambda\lambda\rangle = 16\pi i \frac{\partial}{\partial\tau} W_{\text{eff}} = -\frac{32\pi^2}{N_c} \cdot c M^3 e^{2\pi i\tau/N_c}, \quad (44)$$

or, at $\theta = 0$

$$\langle\lambda\lambda\rangle = -\frac{32\pi^2}{N_c} \cdot c M^3 e^{-8\pi^2/N_c g^2}. \quad (45)$$

This formula accords with our physical intuition in two ways. First, if a gaugino condensate is generated nonperturbatively, the renormalization group requires that the size of this condensate should be set by the nonperturbative QCD scale $\Lambda(g^2, M)$ given in (40). Specifically, we must have

$$\langle\lambda\lambda\rangle = A\Lambda^3, \quad (46)$$

where A is a pure number. Evaluating (40) with $b_0 = 3N_c$, we can see that (45) has precisely this form.

Second, as I explained below (42), the pure supersymmetric Yang-Mills theory should have a Z_{2N_c} global symmetry, $\lambda \rightarrow e^{i\alpha}\lambda$ with $\alpha = 2\pi m/2N_c$. Under this symmetry, the gaugino bilinear is invariant to this transformation for $\alpha = \pi$ or $m = N_c$; thus, an expectation value of this bilinear should break the Z_{2N_c} symmetry spontaneously to Z_2 . This symmetry-breaking would result in N_c inequivalent vacuum states. These states appear explicitly in the formula (44), since the transformations $\theta \rightarrow \theta + 2\pi$ or $\tau \rightarrow \tau + 1$ which are invariances of the Yang-Mills theory sweep out N_c distinct values of the gaugino condensate.

Thus, it is reasonable that supersymmetric Yang-Mills theory should acquire a superpotential of the form (43). Still, this line of reasoning is not quite satisfactory. Though we have shown that the appearance of the superpotential (43) is consistent, we still had to assume that this nonperturbative effect was nonvanishing. To justify this assumption, we must examine some further examples of supersymmetric gauge theories.

4.3 The Affleck-Dine-Seiberg superpotential

Consider next supersymmetric QCD with N_f flavors, for $N_f < N_c$. I have presented the non-anomalous global symmetry of this theory in (33).

We have seen in the previous section that we can also consider the transformation of the theory under anomalous global symmetries as long as we compensate the anomalous transformation laws by an appropriate shift of θ or τ . Thus, I will analyze this theory by making use of the larger symmetry group

$$SU(N_f) \times SU(N_f) \times U_B(1) \times U_A(1) \times U_R(1) \quad (47)$$

which includes the following two anomalous transformations:

$$\begin{aligned} A &: \psi_Q \rightarrow e^{i\alpha}\psi_Q, \quad \psi_{\bar{Q}} \rightarrow e^{i\alpha}\psi_{\bar{Q}}, \quad \text{and} \quad \theta \rightarrow \theta + 2N_f\alpha \\ R &: \psi_Q \rightarrow e^{-i\alpha}\psi_Q, \quad \psi_{\bar{Q}} \rightarrow e^{-i\alpha}\psi_{\bar{Q}}, \quad \lambda \rightarrow e^{-i\alpha}\lambda, \\ &\text{and} \quad \theta \rightarrow \theta + (2N_c - 2N_f)\alpha. \end{aligned} \quad (48)$$

The anomaly-free R symmetry is the combination of these two operations which does not require a transformation of θ . Its $U(1)$ charge is

$$R_{AF} = R + \frac{N_f - N_c}{N_f} A. \quad (49)$$

This symmetry will be important to us at a later stage of our analysis.

It is useful to tabulate the transformation properties of the various fields under the four $U(1)$ symmetries that we have defined:

	B	A	R	R_{AF}	
Q_i	+1	+1	0	$(N_f - N_c)/N_f$	
ψ_{Q_i}	+1	+1	0	$-N_c/N_f$	(50)
\bar{Q}_i	-1	+1	-1	$(N_f - N_c)/N_f$	
$\psi_{\bar{Q}_i}$	-1	+1	-1	$-N_c/N_f$	
λ	0	0	+1	+1	

There are two additional quantities whose quantum numbers will also be important to us. The first is the unique gauge-invariant chiral superfield that we can build from Q_i and \bar{Q}_i ,

$$T_{ij} = Q_i \cdot \bar{Q}_j . \quad (51)$$

We might think of T_{ij} as a meson superfield; its scalar component is a color-singlet combination of scalar quarks. Since T_{ij} transforms as a (N_f, \bar{N}_f) under the $SU(N_f) \times SU(N_f)$ global symmetries, it is especially useful to consider the determinant of this $N_f \times N_f$ matrix, which is invariant under the non-Abelian part of G . The second important quantity is the nonperturbative scale Λ , which transforms under the anomalous $U(1)$ symmetries by virtue of the transformation of θ . The quantum numbers of these objects are:

	B	A	R	R_{AF}	
$\det T$	0	$2N_f$	0	$2(N_f - N_c)$	(52)
Λ^{b_0}	0	$2N_f$	$2(N_c - N_f)$	0	

It is natural to represent the low-energy dynamics of supersymmetric QCD by an effective Lagrangian which is built out of gauge-invariant chiral superfields. This Lagrangian would generalize the structure (7) that we wrote for non-supersymmetric QCD. If we build this Lagrangian out of gauge-invariant combinations of Q_i and \bar{Q}_i , it must be a function of components of T_{ij} .

The superpotential of this effective Lagrangian must be a holomorphic function of T_{ij} and τ which is invariant to the global symmetry group except that it transforms with charge 2 under the R symmetry. There is only one possible function that satisfies these requirements,

$$W_{\text{eff}} = c \cdot \left(\frac{\Lambda^{b_0}}{\det T} \right)^{1/(N_c - N_f)} \quad (53)$$

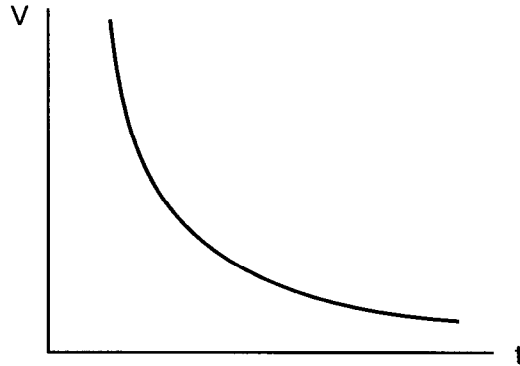

1-97

8264A1

Figure 1: Form of the potential for supersymmetric Yang-Mills theory with $N_f < N_c$.

This is the Affleck-Dine-Seiberg superpotential^{1,26} An alternative method for constructing possible superpotentials would be to construct a function of T that is invariant to the non-anomalous global symmetry group except that it transforms with charge 2 under R_{AF} . Factors of Λ can then be supplied to give the effective superpotential the correct mass dimension 3. This argument also gives (53) as the unique superpotential for this theory.

At first sight, the result (53) looks very bizarre. Differentiating the formula to construct the F term of Q_i , we find

$$F_i = \frac{\partial W_{\text{eff}}}{\partial Q_i} \sim \frac{1}{Q} \cdot \left(\frac{1}{\det Q} \right)^{1/(N_c - N_f)} \quad (54)$$

This expression decreases as the expectation value of Q_i or T_{ij} becomes large. But this is the weak-coupling region where the Kähler potential for Q should take the simple canonical form. Thus, the potential (19) derived from the effective Lagrangian tends to zero as $\langle T \rangle$ tends to infinity as shown in Figure 1. In fact, this potential pushes the theory to a vacuum state at infinity.

However, some careful thinking shows that this is in fact the correct behavior of the model. Consider the alternative possibility that supersymmetric QCD leads to confinement and chiral symmetry breaking, just as in ordinary QCD. In that case, we would expect the quarks to condense in pairs as in (3) or, in our new notation,

$$\langle \psi_{Q_i}^\alpha \cdot \psi_{\bar{Q}_j \alpha} \rangle \neq 0. \quad (55)$$

The gaugino bilinear could acquire an expectation value consistently with supersymmetry. But for the quark bilinear, this is not true; $\psi_{Q_i} \cdot \psi_{\bar{Q}_j}$ is the F term of T_{ij} , and so an expectation value for this expression signals supersymmetry breaking. Since the vacuum energy of a supersymmetric theory is zero only when supersymmetry is unbroken, a QCD-like vacuum with a quark pair condensate is thus unstable with respect to any field configuration—no matter how bizarre—which can allow supersymmetry to remain manifest.

Here is a way to find such a configuration: The D -flatness condition of supersymmetric QCD is

$$D^a = Q^\dagger t^a Q - \bar{Q} t^a \bar{Q}^\dagger = 0. \quad (56)$$

This condition is satisfied by any set of expectation values with $\langle Q_i \rangle = \langle \bar{Q}_i^\dagger \rangle$. By choosing gauge and flavor rotations to diagonalize the $\langle Q_{ik} \rangle$, where k is the gauge group index, we can write this expectation value in the form

$$\langle Q \rangle_{ik} = \begin{pmatrix} a_1 & & 0 & & 0 & \cdots \\ & a_2 & & & 0 & \\ & & \ddots & & & \\ & & & a_{N_f-1} & & 0 \\ 0 & & & & a_{N_f} & 0 & \cdots \end{pmatrix} \quad \langle \bar{Q}_{ik}^\dagger \rangle = 0. \quad (57)$$

Note that this solution has the form of a diagonal matrix acted on by two $U(N_f)$ flavor matrices, just the amount of information encoded in $\langle T_{ij} \rangle$. For a_1, \dots, a_{N_f} large, the gauge symmetry is spontaneously broken

$$SU(N_c) \rightarrow SU(N_c - N_f). \quad (58)$$

In the process, all fermions and bosons which transform under the residual gauge group $SU(N_c - N_f)$ obtain mass. If we send the parameters a_i to infinity, the situation reverts to that of the pure gauge theory, for which we have argued that there is a supersymmetric vacuum with gaugino condensation. This is a vacuum state with zero energy and is therefore the preferred configuration for this theory.

It is interesting to work out some further details of this picture. For simplicity, I will consider the symmetrical configuration $a_1 = \dots = a_{N_f} = v$. Then, for momenta scales $Q > v$, the theory looks like supersymmetric QCD with N_f flavors, while for $Q < v$ it look like a pure supersymmetry gauge theory with gauge group $SU(N_c - N_f)$.

We can compute the effective coupling constant in the pure gauge theory at low energies by matching to the high-energy coupling constant at the scale v . The high-energy behavior, valid for $Q > v$, is

$$\frac{4\pi}{g^2}(Q) = \frac{3N_c - N_f}{2\pi} \log \frac{Q}{\Lambda}. \quad (59)$$

For $Q < v$, the β function of the theory is given by $b_0 = 3(N_c - N_f)$. We parametrize the value of the running coupling constant by a scale Λ_{eff} ,

$$\frac{4\pi}{g^2}(Q) = \frac{3(N_c - N_f)}{2\pi} \log \frac{Q}{\Lambda_{\text{eff}}}. \quad (60)$$

We may obtain an expression for Λ_{eff} by insisting that the running coupling constant should change continuously. Thus, we should set the expressions (59) and (60) equal at the scale v . This gives

$$\left(\frac{\Lambda_{\text{eff}}}{v}\right)^{3(N_c - N_f)} = \left(\frac{\Lambda}{v}\right)^{3N_c - N_f} \quad (61)$$

or

$$\Lambda_{\text{eff}}^3 = \left(\frac{\Lambda^{3N_c - N_f}}{v^{2N_f}}\right)^{\frac{1}{N_c - N_f}}. \quad (62)$$

Finally, we can make use of the result of the previous section that the pure supersymmetric Yang-Mills theory has gaugino pair condensation $\langle \lambda\lambda \rangle \sim (\Lambda_{\text{eff}})^3$, which is the consequence of an effective superpotential

$$W_{\text{eff}} = c \cdot \Lambda_{\text{eff}}^3. \quad (63)$$

Substituting (62) into (63), we find precisely the Affleck-Dine-Seiberg effective superpotential (53).

There is a second way to check the validity of the superpotential (53), by holomorphic decoupling. Start with the effective superpotential for N_f flavors, and add a mass term for the N_f th flavor. The supersymmetric mass term is

$$\Delta W = m Q_{N_f} \cdot \bar{Q}_{N_f} = m T_{N_f N_f}. \quad (64)$$

Then the superpotential of the massive theory is

$$W = c \left(\frac{\Lambda^{b_0}}{\det T}\right)^{\frac{1}{N_c - N_f}} + m T_{N_f N_f}. \quad (65)$$

Now work out the F -flatness conditions for this superpotential. The vanishing of the F -flatness conditions for $T_{N_f i}$ (or for Q_i) imply that $T_{N_f i} = 0$ for $i \neq N_f$. Similarly, $T_{i N_f} = 0$ for $i \neq N_f$. Then T takes the block form

$$T = \begin{pmatrix} \tilde{T} & 0 \\ 0 & t \end{pmatrix}. \quad (66)$$

The F -flatness condition for $T_{N_f N_f} = t$ is

$$-\frac{c}{N_c - N_f} \left(\frac{\Lambda^{b_0}}{\det \tilde{T}} \right)^{1/(N_c - N_f)} \left(\frac{1}{t} \right)^{1+1/(N_c - N_f)} + m = 0, \quad (67)$$

which implies

$$t = \left(\frac{N_c - N_f}{c} m \left(\frac{\Lambda^{b_0}}{\det \tilde{T}} \right)^{1/(N_c - N_f)} \right)^{(N_c - N_f)/(N_c - N_f + 1)} \quad (68)$$

Putting this back into the superpotential, we obtain

$$W = c' \left(\frac{(m \Lambda^{b_0})}{\det \tilde{T}} \right)^{1/(N_c - N_f + 1)}; \quad (69)$$

if $c = (N_c - N_f)$, $c' = (N_c - N_f + 1)$. This is precisely the form of the Affleck-Dine-Seiberg superpotential for $(N_f - 1)$ flavors. Thus, the various effective superpotentials of the family (53) are consistent with one another by decoupling. In these decoupling relations, the various nonperturbative scales Λ are related by the formula

$$(\Lambda^{b_0})_{\text{eff}, N_f - 1} = m (\Lambda^{b_0})_{N_f} \quad (70)$$

It is not difficult to check that this is precisely the relation that is required by a renormalization group analysis similar to the derivation of (62), in which we match running coupling constants above and below the scale $Q = m$.

4.4 $N_f = N_c - 1$

We have now shown that the Affleck-Dine-Seiberg superpotentials are linked to one another by holomorphic decoupling. Then, if this superpotential is known explicitly for any particular value of N_f , we can compute its coefficient for all values of $N_f < N_c$. Thus, to complete the derivation of these superpotentials, we need only find one value of N_f at which we can derive them directly.

Affleck, Dine, and Seiberg showed that there is a direct derivation of the superpotential for the case $N_f = N_c - 1$. In this case, the expectation values for Q_i and \bar{Q}_i given in (57) break the $SU(N_c)$ gauge symmetry completely. For large values of the a_i , the gauge theory never reaches strong coupling and so any terms that appear in the effective Lagrangian must be visible in a weak-coupling analysis. On the other hand, because of the nonrenormalization theorem, a superpotential cannot be generated in any order of perturbation theory. The only gap between these two requirements is the possibility that a superpotential may be generated through a systematic instanton calculation.

The instanton is the leading nonperturbative contribution to gauge theory amplitudes which appears in a weak-coupling expansion. Methods for performing instanton calculations are reviewed in ²⁸. In this article, I will not attempt to obtain the correct coefficient of the instanton amplitude but only to show that it is nonzero. For this purpose, one can view an instanton as a source of chiral fermions. More precisely, if ψ is a fermion matter field in the representation r , the instanton creates $n = 2C(r)$ units of ψ charge. In the model at hand, an instanton creates one each of the ψ_{Q_i} and $\psi_{\bar{Q}_i}$ and $2N_c$ of the λ . On the other hand, the supersymmetric gauge theory contains a vertex proportional to $Q^\dagger \lambda^\alpha \psi_{Q\alpha}$, which can annihilate a λ and a ψ_Q (or $\psi_{\bar{Q}}$) in the presence of a vacuum expectation value of Q (or \bar{Q}). Annihilating all of the λ 's, we are left with an operator of the form

$$\Delta\mathcal{L} = F(Q^\dagger, \bar{Q}^\dagger) \psi^{\dagger\alpha} \psi_\alpha^\dagger \quad (71)$$

which can be rewritten as the Hermitian conjugate of the superpotential term

$$\Delta\mathcal{L} = \int d^2\theta W(Q, \bar{Q}) \quad (72)$$

The amplitude is proportional to one power of

$$M^{b_0} e^{-8\pi^2/g^2 + i\theta} = \Lambda^{b_0}, \quad (73)$$

where the dependence on g^2 follows from the instanton action and the M dependence appears because this factor must be a renormalization group invariant. The dependence of W on Q and \bar{Q} then follows from the fact that W must be an $SU(N_f) \times SU(N_f)$ invariant of mass dimension 3. From these considerations, we obtain

$$W = c \frac{\Lambda^{b_0}}{\det T} \quad (74)$$

with a nonzero value of c . The exact value of c has been obtained by carrying out the instanton calculation explicitly, which has been done in a series of

papers by Cordes,²⁹ Shifman and Vainshtein,³⁰ and Finnell and Pouliot.²⁷ Thus, the Affleck-Dine-Seiberg superpotential can be carefully justified for this case and, by extension, for all cases $N_f < N_c$.

As a final comment on these models, I would like to note that the potential we have found, which pushes the vacuum state to infinity, is actually not so inconsistent with the familiar symmetry-breaking pattern of nonsupersymmetric QCD. Given the potential in the supersymmetric case, we can break supersymmetry explicitly by adding a positive mass term for the scalar quarks only,

$$\Delta\mathcal{L} = -m^2 (|Q|^2 + |\bar{Q}|^2) . \quad (75)$$

This term pulls the minimum of the potential back from infinity to some large but finite value of $\langle T_{ij} \rangle$. The minimum occurs for an expectation value

$$\langle T_{ij} \rangle = A\delta_{ij} , \quad (76)$$

and so the vacuum of the modified theory spontaneously breaks $SU(N_f) \times SU(N_f)$ to the diagonal $SU(N_f)$. This is just the symmetry-breaking pattern of nonsupersymmetric QCD. As m^2 increases, the expectation value $\langle T \rangle$ decreases while $\langle F_T \rangle = \langle \psi_Q \cdot \psi_{\bar{Q}} \rangle$ increases. Thus, it is reasonable that, as m^2 is sent to infinity, the vacuum state we have found goes over smoothly to the QCD vacuum with a nonzero quark pair condensate.³¹ The only thing that is still peculiar about this transition is that its starting point, for small m^2 , is a Higgs phase and its endpoint, at large m^2 , is a confining or Wilson phase. But we have already seen that these two situations are not distinguished by any gauge-invariant expectation values and that it is possible to make a smooth transition between them. We will see additional examples of such transitions as we proceed.

4.5 $N_f = N_c$

Now that we have understood the behavior of supersymmetric QCD for $N_f < N_c$, it is natural to ask what happens for larger values of N_f . I will discuss this question in full detail in Section 7. But I would like to give a preview of that discussion now by considering the case $N_f = N_c$.

It is tempting to think of this next case as a smooth extrapolation of the cases discussed in this section. However, it cannot be. Most clearly, the formula (53) for the Affleck-Dine-Seiberg superpotential is singular or meaningless at $N_f = N_c$. To see the origin of this difficulty, notice from (49) that the canonical R symmetry is has no anomaly and from (50) that the elementary fields Q and \bar{Q} have R charge zero. Thus, it is impossible to build a superpotential with R charge 2 out of these ingredients.

There is another new feature in the case $N_f = N_c$. This is the first case in which it is possible to build gauge-invariant chiral fields with the quantum numbers of baryons. We have two such terms here,

$$\begin{aligned} B &= \epsilon_{a_1 \dots a_{N_c}} Q_1^{a_1} \dots Q_{N_c}^{a_{N_c}} \\ \bar{B} &= \epsilon_{a_1 \dots a_{N_c}} \bar{Q}_1^a \dots \bar{Q}_{N_c}^{a_{N_c}} ; \end{aligned} \quad (77)$$

the lowered indices denote the flavor, as before, and the raised indices denote the color.

I pointed out earlier that the solutions of the D -flatness equations are parametrized by gauge-invariant polynomials. Thus, the appearance of new gauge-invariants should be accompanied by the appearance of new families of the solutions to the D -flatness conditions. In this case, there is a new solution of the form

$$\langle Q \rangle = \begin{pmatrix} a & & & 0 \\ & a & & \\ & & \ddots & \\ & & & a \\ 0 & & & & a \end{pmatrix} \quad \langle \bar{Q}^\dagger \rangle = 0 \quad (78)$$

A second solution is obtained by reversing the roles of Q and \bar{Q}^\dagger in (78). However, this should not be counted as a new solution, since it is a combination of the above and a solution with $\langle Q \rangle = \langle \bar{Q}^\dagger \rangle$. Through the correspondence between solutions and gauge-invariant polynomials, this implies that the three polynomials T , B , and \bar{B} should not be independent. Indeed, classically, they obey the relation

$$\det T = B\bar{B} . \quad (79)$$

It is very tempting to think of the low-energy dynamics of this theory as being described by the fields T , B , and \bar{B} fluctuating subject to the constraint (79). There can be no superpotential generated, and so the composite chiral fields sweep out a manifold of supersymmetric vacuum states.

However, Seiberg has argued that this manifold of vacua is distorted by nonperturbative effects.³² In fact, there is no symmetry which prohibits the modification of the constraint (79) to

$$\det T - B\bar{B} = \Lambda^{2N_c} . \quad (80)$$

All of the terms in this equation have $R = 0$ and mass dimension $2N_c$. In addition, (80) gives a different result from that of (79) under holomorphic

decoupling. To see this, add a mass term for the last flavor by adding to the theory the superpotential

$$W = m T_{N_f N_f} . \quad (81)$$

Let $t = T_{N_f N_f}$, and consider this field to be determined in terms of the other fields by the constraint. The F -flatness conditions for B , \bar{B} , and $T_{N_f j}$ for $j < N_f$ are then solved by setting these components equal to zero. This leaves T in the form that we have seen in (66),

$$T = \begin{pmatrix} \tilde{T} & 0 \\ 0 & t \end{pmatrix} , \quad (82)$$

and the constraint (80) now implies $\det \tilde{T} \cdot t = \Lambda^{2N_c}$. Inserting the constrained value of t into (81), we find

$$W = \frac{m \Lambda^{2N_c}}{\det \tilde{T}} . \quad (83)$$

The renormalization group relation for the effective Λ parameter (70) implies that the numerator of (83) can be replaced by Λ^{b_0} for the effective theory with $(N_c - 1)$ flavors. This is precisely the Affleck-Dine-Seiberg superpotential.

Among plausible forms for the constraint among the gauge-invariant effective fields, only the version (80) with Seiberg's quantum modification is consistent through decoupling with our results for $N_f < N_c$. Thus, we find a space of supersymmetric vacuum states parametrized by T , B , and \bar{B} obeying this constraint. The space of vacuum states resembles the space of solutions to the classical D -flatness conditions when the vacuum expectation values of these fields are large. However, when the vacuum expectation values become small, the space becomes distorted in such a way that it no longer contains the point $T = B = \bar{B} = 0$. I will have more to say about this case, and about the cases for $N_f > N_c$, in Section 7.

The case of supersymmetric QCD with $N_f = N_c$ provides a first example of a theory with a manifold of vacuum states. Actually, this is a common situation in supersymmetric Yang-Mills theories. In any situation for which there is a continuous family of solutions to the conditions for unbroken supersymmetry, we will find a manifold of degenerate vacuum states with zero energy. This manifold will typically be parametrized by the expectation values of chiral superfields; thus, it will be a complex Kähler manifold. It is common to call this space the 'moduli space' of the theory, and I will use that terminology from here on.

5 The Seiberg–Witten Model

In the previous examples, the low-energy dynamics of the gauge theory contained only chiral multiplets, while all of the gauge charges were either confined or spontaneously broken. So it would be good to illustrate that it is also possible for the low-energy gauge symmetry to be realized in the Coulomb phase. The simplest illustrative model of this type is the celebrated model of Seiberg and Witten.²

Consider $SU(2)$ Yang-Mills theory with an extra chiral superfield ϕ in the *adjoint* representation of the gauge group. With the superpotential set to zero, the Lagrangian of the theory is

$$\mathcal{L} = \int d^4\theta \frac{1}{g^2} \phi^\dagger e^V \phi - \frac{i}{16\pi} \int d^2\theta \tau W^{\alpha a} W_\alpha^a + h.c. \quad (84)$$

This model is in fact the pure Yang-Mills theory with $N = 2$ supersymmetry. The two gauginos of the theory are λ and ψ_ϕ ; I have put a factor $1/g^2$ in front of the ϕ kinetic energy term to make the symmetry relation of these two fields more clear. My discussion of this model will be given mainly in $N = 1$ notation, and the conclusions will apply to similar models which are only $N = 1$ supersymmetric. Nevertheless, as I will discuss later, the $N = 2$ supersymmetry has interesting consequences that will help us in our analysis.

5.1 Parametrization of the vacuum states

The classical potential of the model comes only from the D -term contribution

$$V = \frac{g^2}{2} (D^a)^2, \quad \text{where} \quad D^a = \frac{1}{g^2} \phi^\dagger t^a \phi. \quad (85)$$

The D term is most clearly written by expressing ϕ and D as matrices: $\phi = \phi^a t^a$, $D = D^a t^a$. Then

$$D = \frac{i}{g^2} [\phi^\dagger, \phi]. \quad (86)$$

Thus $D = 0$ if ϕ and ϕ^\dagger can be simultaneously diagonalized. Since these are $SU(2)$ matrices, this condition implies that there is a gauge rotation such that

$$\langle \phi^b \rangle = a \delta^{b3}, \quad (87)$$

with a a complex number. This expectation value spontaneously breaks $SU(2)$ to $U(1)$. Notice that the classical potential equals zero for any value of a .

Expanding the classical Lagrangian about any of the points (87), one finds that all of the the fields charged under the $U(1)$ receive mass from the ϕ vacuum

expectation value. The fields that remain massless are the $U(1)$ gauge boson A_μ^3 , the fermions λ^3 and ψ_ϕ^3 , and the complex scalar ϕ^3 . It is clear that the vector and the scalar must remain massless: The vector field is the gauge field of an unbroken gauge symmetry, and the scalar field is the fluctuation along a manifold of degenerate vacuum states. Together with their superpartners, these states fit together into an $N = 2$ supersymmetry multiplet.

Since the massless fields of the model are noninteracting at large distances, all of the vacuum states (87) belong to the Coulomb phase of the $U(1)$ gauge symmetry. And some additional structure is present: Because a non-Abelian gauge group is spontaneously broken to $U(1)$, this theory has 't Hooft-Polyakov magnetic monopoles.^{33,34} The $N = 2$ supersymmetry of the model and the flatness of the potential for a implies that these monopoles are regulated by a Bogomolny-Prasad-Sommerfield (BPS) inequality.^{35,36} The general properties of these magnetic monopole solutions are described in Harvey's lectures at this school.³⁷

Classically, the vacuum states of the theory are related by a $U(1)$ symmetry

$$\phi \rightarrow e^{i\alpha} \phi, \quad \psi_\phi \rightarrow e^{i\alpha} \psi_\phi. \quad (88)$$

However, as in supersymmetric QCD, this symmetry is broken by a gauge anomaly. Equivalently, the transformation (88) is equivalent to a shift of the θ parameter,

$$\theta \rightarrow \theta - 4\alpha, \quad \text{or} \quad \tau \rightarrow \tau - \frac{4}{2\pi} \alpha. \quad (89)$$

Since a shift of θ by 2π is a symmetry of the theory, we could also say that the original model is invariant under the discrete symmetry

$$\phi \rightarrow e^{i\frac{\pi}{2}} \phi. \quad (90)$$

Though we can reasonably parametrize the vacuum states at weak coupling by the expectation value of ϕ , this is not a useful way to describe these vacua in the strong-coupling region, because ϕ is not a gauge-invariant quantity. I will now propose two different ways to generalize the definition of the parameter a introduced above so that it makes sense in all regions in which we would like to analyze the theory. First of all, we could characterize the vacuum by the vacuum expectation value of the gauge-invariant operator

$$u = \langle (\phi^a)^2 \rangle. \quad (91)$$

In the weak-coupling region, $u \approx a^2$. The chiral symmetry (90) is realized on u as a Z_2 symmetry

$$u \rightarrow -u. \quad (92)$$

Another generalization of a involves the particle mass spectrum. At weak coupling, in the normalization introduced above, the W bosons acquire mass $m_W = \sqrt{2}a$ from the Higgs mechanism, where $a = \langle \phi^3 \rangle$. The magnetic monopoles have mass $m_M = 4\pi\sqrt{2}a/g^2$. The BPS inequality implies that, at all values of the coupling, these particle masses satisfy a relation of the form

$$m = \sqrt{2} |a Q_e + a_D Q_M| \quad (93)$$

where Q_e, Q_M are the electric and magnetic charges and a and a_D are some constants. Thus, we can consider the coefficient a in this formula to be the gauge-invariant generalization of the vacuum expectation value of ϕ . The coefficient a_D should be determined uniquely by the value of a and the effective large-distance coupling constant g^2 or τ .

At weak coupling, a_D obeys the relation

$$a_D \approx \frac{4\pi i}{g^2} a = \tau \cdot a . \quad (94)$$

However, this cannot be an exact relation in the theory. The effective coupling τ is determined, at least in part, by the renormalization group running of the coupling constant in the $SU(2)$ gauge theory from the fundamental short-distance scale down to the scale a . But the formula $a_D = \tau(a)a$ is not renormalization-group invariant. Seiberg and Witten proposed the formula

$$\tau = \frac{da_D}{da} . \quad (95)$$

This relation is consistent with a nontrivial dependence of τ on a . It also suggests a duality symmetry

$$a \leftrightarrow a_D , \quad \tau \leftrightarrow -1/\tau = \tau_D . \quad (96)$$

Some motivation for the formula (95) is given by computing the magnetic monopole mass in the weak-coupling limit of the effective $U(1)$ gauge theory. In that limit, the monopole mass is given by

$$m = \int d^3x \left(\frac{1}{g^2} |\vec{\nabla} a|^2 + \frac{1}{2g^2} (\vec{B})^2 \right) . \quad (97)$$

Using (95), we can transform the first term using the relation $\tau \vec{\nabla} a = \vec{\nabla} a_D$, to give

$$\begin{aligned} m &= \int d^3x \left(\frac{g^2}{(4\pi)^2} |\vec{\nabla} a_D|^2 + \frac{1}{2g^2} (\vec{B})^2 \right) \\ &= \int d^3x \left| \frac{g}{4\pi} \vec{\nabla} a_D \pm \frac{1}{\sqrt{2}g} \vec{B} \right|^2 \mp \frac{\sqrt{2}}{4\pi} \int d^3x \vec{\nabla} (a_D \vec{B}) . \end{aligned} \quad (98)$$

Then, finally

$$m \geq \frac{\sqrt{2}}{4\pi} \int d^2s \hat{n} \cdot a_D \vec{B}, \quad (99)$$

consistent with (93). However, we will obtain much stronger tests of the relation (95), which also can be made in the strong-coupling region, by examining the properties this relation predicts for the θ -dependence of the properties of magnetic monopoles.

I have already noted that the vacuum parameter, or ‘modulus’, a , the $U(1)$ gauge boson, and the fermionic partners of these fields fit together into an $N = 2$ supermultiplet. Now that we have seen that these fields can be characterized in a gauge-invariant way, it makes sense to write an effective Lagrangian which could describe their dynamics. The most general possible such Lagrangian is

$$\mathcal{L} = \int d^4\theta K(a, \bar{a}) - \frac{i}{16\pi} \int d^2\theta \tau(a) W^\alpha W_\alpha + h.c. \quad (100)$$

The $N = 2$ supersymmetry forbids a superpotential. It also relates τ and K through a ‘prepotential’ $\mathcal{F}(a)$:

$$\tau = \frac{\partial^2 \mathcal{F}}{\partial a^2} \quad K = \frac{1}{4\pi} \text{Im} \frac{\partial \mathcal{F}}{\partial a} \bar{a}. \quad (101)$$

Using (95), we can evaluate

$$K = \frac{1}{4\pi} \text{Im} a_D \bar{a}, \quad (102)$$

which is also symmetric under electric-magnetic duality.

In (101), I have written τ as a function of a . In fact, the three complex variables τ , a_D , and a are tied together by the relation (95). All three of these variables can be thought of as functions of u defined in (91). To understand the qualitative behavior of the model, we should try to determine the explicit dependence of these quantities on u .

To determine $\tau(u)$, we will make essential use of the fact that the relations among τ , a , a_D , and u are holomorphic. In particular, the holomorphic function $\tau(u)$ can be reconstructed from the knowledge of its singularities and its behavior at infinity. However, a singularity in the effective coupling constant must be associated with divergent coupling constant renormalization, and this is possible only if very light states appear in the physical spectrum. The strategy of Seiberg and Witten is then to determine the singularities of $\tau(u)$ from physical arguments and then to construct the global function from the properties of these singularities.

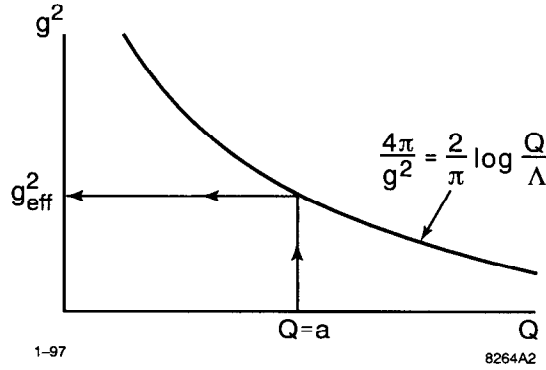

Figure 2: Determination of the effective coupling constant in the weak-coupling limit of the Seiberg-Witten model.

5.2 Weak-coupling behavior of $\tau(u)$

To begin this program, we might first analyze the behavior of $\tau(u)$ in the limit $u \rightarrow \infty$. This corresponds to the weak-coupling region of the theory, and so we can obtain the relation between τ and u from a weak-coupling renormalization group analysis.

In pure $N = 2$ Yang-Mills theory, the formula (36) gives

$$b_0 = 2N_c, \quad (103)$$

or $b_0 = 4$ in the $SU(2)$ theory. The running coupling constant is then given by (18):

$$\frac{4\pi}{g^2}(Q) = \frac{4\pi i}{g^2} + \frac{4}{2\pi} \log \frac{Q}{M} \quad (104)$$

In the theory with spontaneously broken symmetry, the coupling constant will run from the short-distance scale M to the scale a , and then stop at the mass scale of the particles with nonzero $U(1)$ charge, as shown in Figure 2. Thus, the effective coupling at $\theta = 0$ should be given by $\tau(a) = 4\pi/g^2(a)$, plus a possible constant shift from one-loop corrections at the scale a . We can absorb this shift into the Λ parameter. Using also the relation (91), we can write the holomorphic relation between τ and u as

$$\tau(u) = \frac{i}{\pi} \log \frac{u}{\Lambda^2}. \quad (105)$$

We can check this formula in a nontrivial way by thinking about the implications of this formula for the dependence of the effective Lagrangian and the

monopole masses on the phase of u . First of all, the phase rotation $u \rightarrow e^{2i\alpha}u$ should be equivalent to the shift of θ by (88), and this relation is nicely realized in (105). The weak-coupling relation $u = a^2$ can be combined with (95) to evaluate a_D as

$$a_D = \frac{2i}{\pi} \left(a \log \frac{a}{\Lambda} - a \right). \quad (106)$$

Then under the rotation $a \rightarrow e^{i\alpha/4}a$, which corresponds to $\theta \rightarrow \theta - \alpha$,

$$a_D \rightarrow e^{i\alpha/4} \left(a_D - \frac{\alpha}{2\pi} a \right). \quad (107)$$

Then the BPS bound becomes

$$m \rightarrow \sqrt{2} \left| a \left(Q_E - \frac{\alpha}{2\pi} Q_M \right) + a_D Q_M \right|. \quad (108)$$

This is just right. In the presence of a nonzero θ parameter, a magnetic monopole acquires an additional electric charge $\theta Q_M / 2\pi$.³⁸ The effect of the nonzero θ generated by the rotation of a thus shifts the monopole electric charges in precisely the manner indicated in (108).

To push this picture a little further, recall that the classical solutions of the theory we are considering include not only magnetic monopoles but also dyons.³⁷ The magnetic monopole solution can be deformed to a solution rotating in the $U(1)$ direction, and each such solution with quantized angular momentum gives a new, electrically charged, solution. Thus, in weak coupling at $\theta = 0$, the spectrum of the model includes a tower of states with $Q_M = 1$ and all integer values of the electric charge, and a similar tower for $Q_M = -1$. All of these particles obey the BPS mass formula (93). The particle spectrum of the theory at weak coupling is shown in Figure 3(a).

All of these states are affected by the shift of θ induced by a phase rotation of u or a . Under the transformation (107), the positively charged dyons become lighter while the negatively charged dyons become heavier. When we have gone half-way around the u plane, $u \rightarrow e^{i\pi}u$ or $a \rightarrow e^{i\pi/2}a$, the spectrum goes back to its original form, but with the dyon which originally had charge $Q_E = 1$ becoming the lightest particle with magnetic charge. This transformation is shown in Figure 3(b). If we had rotated around the u plane in the other direction, we would have found as the lightest monopole the dyon which had $Q_E = -1$ at $\theta = 0$.

The fact that the model has the same spectrum when we carry $u \rightarrow -u$ should be no surprise, because these points are related by the Z_2 symmetry (92). It is a surprise, though, that this identity of the spectra is realized thorough a rearrangement of the states. Similarly, when we come back to the

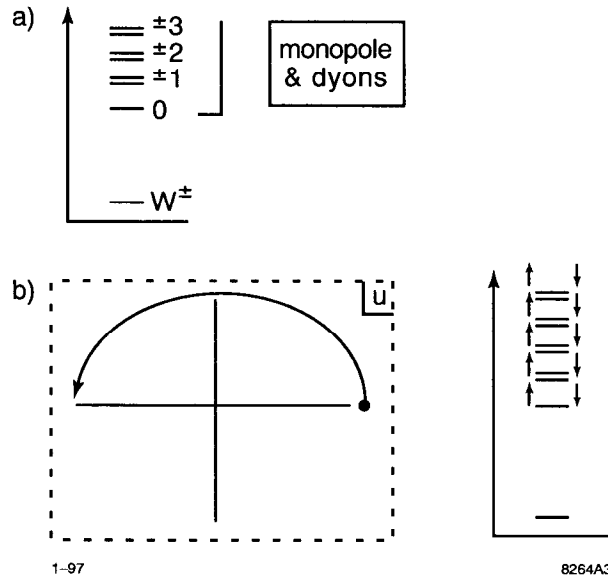

Figure 3: (a) Spectrum of W bosons, monopoles, and dyons in the weak-coupling limit of the Seiberg-Witten model with $\theta = 0$. (b) Transformation of the spectrum of monopole and dyon states as we turn on θ or rotate u in the weak-coupling region.

original value of u after a 2π circuit of the u plane, we find the same spectrum shifted by 2 units. This behavior is suggested by the form of (105), which is a branched function of u . In fact, we now see that the whole theory has a branched structure in u , rather than being single-valued as a function of this variable.

5.3 Strong-coupling singularities of $\tau(u)$

If the function $\tau(u)$ has a branch cut singularity at large values of u , this branch cut must originate at some point or points in the interior of the u plane. We will now try to find and characterize these points.

At first sight, it seems possible that (105) could be exact. It is true that there are no perturbative corrections to (79), since any modification of this equation by logarithms of u would destroy the transformation properties of a and a_D under a shift of θ that we have just discussed. However, (105) can be

corrected by nonperturbative effects

$$\tau(u) = \frac{i}{\pi} \log \frac{u}{\Lambda^2} + au^{-2} + bu^{-4} + \dots \quad (109)$$

Because of the Z_2 symmetry (92), only even powers of u can appear. Solving for u perturbatively, one can see that $u^{-2} \sim e^{-8\pi^2/g^2}$, characteristic of a one-instanton correction. In fact, these leading instanton corrections have been evaluated and are nonzero.^{27,39} So we will need a more sophisticated hypothesis.

The next simplest idea is that nonperturbative effects in the theory generate a scale u_0 proportional to Λ , and that $\tau(u)$ has a pair of singularities at $u = \pm u_0$. The presence of a pair of singularities is required by the Z_2 symmetry. In fact, there is a pleasing physical picture of the origin of these singularities. As u decreases, the coupling constant should increase. This will cause the parameter a_D to decrease and thus should lower the masses of the monopoles. As long as a is nonzero, the dyons with nonzero Q_E must remain massive, but the lightest monopole with $Q_E = 0$ could come down to zero mass. This evolution is shown in Figure 4. We will then assume that a_D has a zero at a point u_0 on the real axis. At the reflected point $u = -u_0$, the dyon which has charge 1 for real positive u , which becomes the lightest dyon on the negative real axis, comes down to zero mass in the same way.

This picture leads to an explicit expression for the singularity of $\tau(u)$ at $u = 0$. Near this point, the only light states in the theory are magnetic monopoles with zero electric charge. These monopoles renormalize the effective coupling in such a way as to screen the dual coupling constant $\tau_D = -1/\tau$. The β function of this dual theory is the same as that in supersymmetric quantum electrodynamics with one charged species, $b_0 = -2$. (This is (36) with $C_2(G_c) = 0$ and $C(r) = 1$ for each chiral multiplet.) Then

$$\tau_D = -\frac{2i}{2\pi} \log m_M \quad (110)$$

where m_M is the monopole mass. I will assume that a_D is nonsingular at u_0 with a simple zero,

$$a_D \approx b(u - u_0) . \quad (111)$$

Then, since $m_M = \sqrt{2}a_D$,

$$\tau_D = -\frac{1}{\tau(u)} = \frac{-i}{\pi} \log(u - u_0) . \quad (112)$$

From the expressions for τ and a_D , we can reconstruct the formula for a near $u = u_0$. Since

$$\frac{da}{da_D} = -\tau_D = \frac{i}{\pi} \log a_D , \quad (113)$$

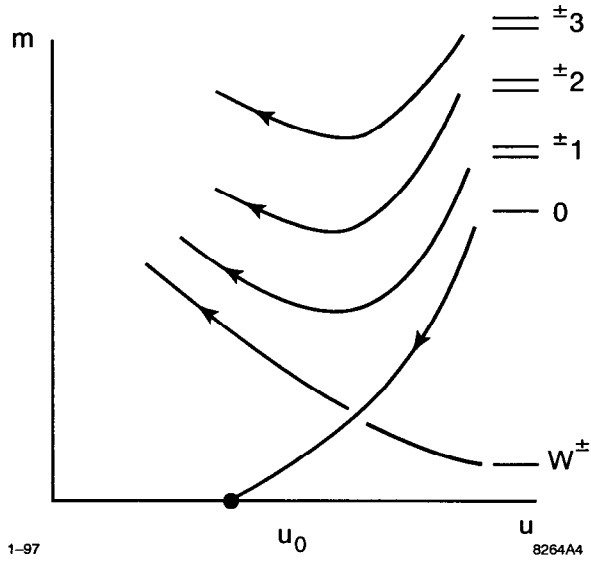

Figure 4: Dependence of monopole and dyon masses on u along the positive real axis of the u plane.

we find

$$a = \frac{i}{\pi} (a_D \log a_D - a_D). \quad (114)$$

The singularity of $\tau(u)$ at $u = -u_0$ must be the mirror image of the singularity at $u = u_0$. To compute the behavior of τ , a , and a_D at this point, start at large real positive u , and go around the outside of the complex u plane from to the point $ue^{i\pi}$ on the negative real axis. The new values of a and a_D are

$$a \rightarrow \tilde{a} = ia, \quad a_D \rightarrow \tilde{a}_D = i(a_D - a) \quad (115)$$

The transformed a_D must have a simple zero which is the image of (111),

$$\tilde{a}_D \sim (u + u_0). \quad (116)$$

Then, in the vicinity of $u = -u_0$, $\tau(u)$ has a singularity given by

$$\tau_D = -\frac{1}{\tau(u)} = \frac{-i}{\pi} \log(u + u_0). \quad (117)$$

and a has the singular behavior

$$\tilde{a} = \frac{i}{\pi} (\tilde{a}_D \log \tilde{a}_D - \tilde{a}_D). \quad (118)$$

The branched behavior of τ around each of these singularities is most clearly demonstrated by the transformation of a and a_D around each of the singularities. If we make a 2π circuit of the u plane for large u , (107) implies that a and a_D return to the values

$$a \rightarrow -a, \quad a_D \rightarrow -(a_D - a). \quad (119)$$

Around the singularity at $u = u_0$, (114) implies the transformation

$$a \rightarrow a - 2a_D, \quad a_D \rightarrow a_D. \quad (120)$$

Around the singularity at $u = -u_0$, \tilde{a} and \tilde{a}_D go through the same transformation. Replacing these by a and a_D using (115), we find

$$a \rightarrow 3a - 2a_D, \quad a_D \rightarrow 2a - a_D. \quad (121)$$

Such transformations of functions around a complex singularity are called 'monodromies'. In this case, we can characterize each singularity by a 2×2 monodromy matrix M , by writing

$$a_D \text{ choose } a \rightarrow M \begin{pmatrix} a_D \\ a \end{pmatrix}. \quad (122)$$

For the three singularities,

$$M_\infty = \begin{pmatrix} -1 & 2 \\ 0 & -1 \end{pmatrix}, \quad M_{u_0} = \begin{pmatrix} 1 & 0 \\ -2 & 1 \end{pmatrix}, \quad M_{-u_0} = \begin{pmatrix} -1 & 2 \\ -2 & 3 \end{pmatrix}. \quad (123)$$

Since u is by definition nonsingular on the u plane, the doublet

$$\begin{pmatrix} da_D/du \\ da/du \end{pmatrix} \quad (124)$$

has the same monodromies. From the components of this vector, we can reconstruct $\tau(u)$ as

$$\tau(u) = \frac{(da_D/du)}{(da/du)}. \quad (125)$$

At this moment, there is no guarantee that we have discovered all of the singularities of $\tau(u)$. However, it is possible to check that the branch cuts which

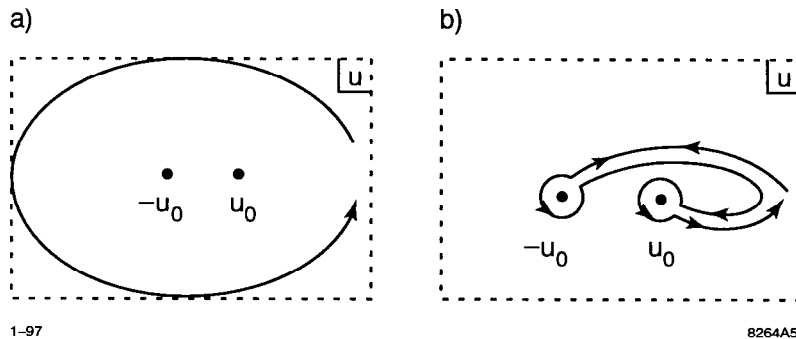

Figure 5: Relation of the monodromies about the three singularities of $\tau(u)$.

originate at u_0 and $-u_0$ are sufficient to account for the branched behavior of $\tau(u)$ at infinity. Around the path shown in Figure 5(a), a and a_D should have the monodromy M_∞ . If $\tau(u)$ has no singularities other than those we have already identified, this path can be deformed continuously to that shown in Figure 5(b). Notice that the path to and from $u = -u_0$ passes above the singularity at $u = u_0$ and thus belongs to the branch for which we have derived (121). The test that no other singularities are needed is the equality of these transformations, that is,

$$M_{u_0} M_{-u_0} = M_\infty . \quad (126)$$

And, indeed, this follows from (123).

5.4 Geometry of the moduli space

Now that we have determined the singularity structure of $\tau(u)$, we should be able to reconstruct the function explicitly. In principle, this could be done completely algebraically. However, there are two clues in the information we have uncovered which suggested to Seiberg and Witten a geometrical solution to this problem. The first is the general property that the effective coupling $g^2(u)$ must be positive. This restricts $\tau(u)$ by

$$\text{Im } \tau = \frac{4\pi}{g^2} > 0 . \quad (127)$$

The explicit formula for τ must naturally respect this relation. The second is the set of monodromy relations, which induce specific quantized shifts of τ as we move around each singularity. Both of these properties suggest that τ is the modulus of a torus.

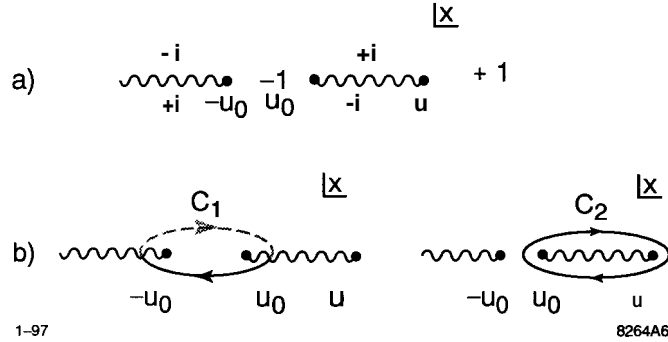

Figure 6: (a) The singularities of $y(x)$, and a branch choice for the square root. (b) The contours C_1 and C_2 used to define the translations z_1 and z_2 .

A convenient way to construct these tori is to use the following representation: Let

$$y^2 = (x - u_0)(x + u_0)(x - u) \quad (128)$$

and consider the integral

$$z = \int_{u_0}^x \frac{dx}{[(x - u_0)(x + u_0)(x - u)]^{1/2}} = \int_{u_0}^x \frac{dx}{y} \quad (129)$$

For definiteness, choose the branch of the square root such that, when u is real, positive, and greater than u_0 , the square root has the phases shown in Figure 6(a).

The integral $z(x)$ is a mapping from the two-sheeted x plane to a torus. When u is real and positive, as x moves from u_0 along the positive real axis, z moves in the imaginary direction in the complex plane. As x is moved to the left of u_0 , z moves along the positive real axis. Complete circuits along the contours C_1 and C_2 shown in Figure 6(b) carry z into the values

$$z_1 = \oint_{C_1} \frac{dx}{y}, \quad z_2 = \oint_{C_2} \frac{dx}{y}. \quad (130)$$

These are the fundamental translations on a torus of modulus

$$\tau(u) = z_2/z_1 \quad (131)$$

It is not difficult to see that the double-sheeted x plane is mapped 1-to-1 onto this torus. For example, the upper half plane on the first sheet in x is mapped

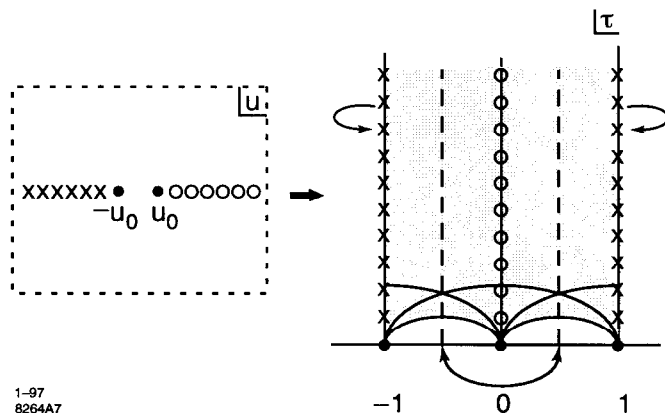

Figure 7: The mapping from the u plane to the space of torus moduli τ .

into the rectangle whose corners are $z = 0, z_1/2, z_2/2, (z_1 + z_2)/2$. Then

$$\frac{da}{du} = Az_1, \quad \frac{da_D}{du} = Az_2, \quad (132)$$

where the common constant $A = 1/4\pi$ can be determined from the relation $a \rightarrow \sqrt{u}$ as $u \rightarrow \infty$.

It is straightforward to see that (131) and (130) do indeed construct a function with the properties of $\tau(u)$. The function that we have defined has singularities at only at $u = \pm u_0$. By taking $u \gg u_0$, one can verify the form (105). By carrying u around u_0 , and paying close attention to the branches of the square root in the various segments of the integral, one can verify the monodromy relation (120).

Once $\tau(u)$ has been determined in this way, it is possible to make a quite nontrivial check on the solution by comparing the coefficients a and b in (109) with the explicit results of one- and two-instanton calculations. The check confirms the Seiberg-Witten solution^{27,39}

The mapping from the u plane to the space of moduli τ is quite interesting. As $u \rightarrow \infty$, $z_2 \rightarrow i\infty$ with z_1 fixed, so we find a tall, thin torus (the 'Witten torus'). As $u \rightarrow u_0$, $z_2 \rightarrow 0$, and so we find a short, fat torus (the 'Peskin torus'). As $u \rightarrow -u_0$ from above or below the real axis, $z_2 \rightarrow \pm 1$ and we find a short torus twisted through 2π . The full mapping of the u plane is shown in Figure 7. The image of the u plane covers four copies of the fundamental region of the modular group. It is, in fact, the fundamental region of the subgroup

$\Gamma(2)$ of $SL(2, Z)$.

5.5 Relation to $N = 1$ Yang-Mills theory

Another way to confirm our understanding of the $N = 2$ $SU(2)$ Yang-Mills theory is to explicitly break the $N = 2$ supersymmetry to $N = 1$. This is easily done by adding a mass term for the ϕ supermultiplet to the Lagrangian (84). When the field ϕ and its fermionic partner are decoupled, the theory should revert to the $N = 1$ pure Yang-Mills theory that we discussed in Section 4.2. It is not at all obvious that this correspondence can be made. In our earlier discussion, we analyzed the $N = 1$ Yang-Mills theory as a theory of confinement; our analysis of the $N = 2$ theory was based on the realization of this model in the Coulomb phase. How could these descriptions be connected?

In any case, we can carry out the analysis. To add a mass term for ϕ , add the superpotential

$$\Delta W = \frac{1}{2} m \phi^2 = \frac{1}{2} m u . \quad (133)$$

At a typical point in the strong-coupling region, u is the only light chiral superfield, so (133) is the full effective superpotential. Then the F -flatness condition $\partial W / \partial u = 0$ cannot be satisfied.

Near $u = u_0$, there is a better situation. A set of magnetic monopoles become light and so we should include magnetic monopole fields in the effective Lagrangian. To write a mass term, we need a pair of chiral superfields M and \bar{M} , which create the $Q_E = 0$ monopole and antimonopole. These two fields form an $N = 2$ hypermultiplet. The effective superpotential then takes the form

$$W_{\text{eff}} = \sqrt{2} b (u - u_0) M \bar{M} + \frac{1}{2} m u , \quad (134)$$

where I have used the expression (111) to write the monopole mass as a function of u .

The F -flatness conditions following from (134) are

$$(u - u_0) M = (u - u_0) \bar{M} = 0 \quad \sqrt{2} b M \bar{M} + \frac{1}{2} m = 0 . \quad (135)$$

The solution of these conditions is

$$u = u_0 \quad M = \bar{M} = \left(\frac{-m}{2\sqrt{2}b} \right)^{1/2} , \quad (136)$$

up to a $U(1)$ gauge transformation on M, \bar{M} .

Thus, in the presence of the superpotential (133), the manifold of vacuum states characteristic of the Coulomb phase is lifted away from zero energy. Only two discrete supersymmetric configurations remain, the vacuum we have found at $u = u_0$ and a mirror-image vacuum at $u = -u_0$. In fact, we showed in Section 4.2 that the $N = 1$ supersymmetric gauge theory should have precisely two vacuum states, reflecting the spontaneous global symmetry breaking from $G = Z_4$ to Z_2 .

A remarkable property of the vacuum states at $u = \pm u_0$ is that the magnetic monopole fields acquire vacuum expectation values. These vacuum states are realized in the Higgs phase of the magnetic $U(1)$ theory. Dually, they belong to the confining phase of the original Yang-Mills theory, according to the criteria for confinement that we discussed in Section 2.2.

6 More Phenomena of the Coulomb Phase

There is much more to say about properties of the Coulomb phase of supersymmetric gauge theories. In this section, I would like to highlight two particularly interesting physical phenomena which appear already in the simplest extension of the Seiberg-Witten model. Then I will discuss some models which generalize the geometrical structure of the space of vacua which we found in Section 5.4.

6.1 $N = 2$ $SU(2)$ Yang-Mills theory with matter

It is a natural generalization of the Seiberg-Witten model discussed in the previous section to add some number of matter fields which couple to the gauge symmetry. In an $N = 2$ supersymmetric theory, matter fields belong to $N = 2$ hypermultiplets, which are pairs of $N = 1$ chiral supermultiplets (Q_i, \bar{Q}_i) in conjugate representations of the gauge group. In $N = 1$ language, the Lagrangian consists of the standard coupling of the gauge multiplet to these fields, plus the superpotential

$$W = 2 \sum_i \bar{Q}_i \phi^a t^a Q_i , \quad (137)$$

which couples the fields ϕ, ψ of the $N = 2$ gauge multiplet to the hypermultiplets.

For $SU(N_c)$ gauge theories with matter in the fundamental representation, the β function is given by

$$b_0 = 2N_c - N_f ; \quad (138)$$

thus, the theories are asymptotically free with any number of matter multiplets up to $2N_c$. For $SU(N_c)$ gauge theories with matter in the adjoint represen-

tation, adding one hypermultiplet already gives $b_0 = 0$. This latter theory, which has a total of four chiral fermions and six real scalars in the adjoint representation, is precisely the $N = 4$ supersymmetric Yang-Mills theory.

Since the $N = 2$ theories with matter have a superpotential, the classical vacuum states are determined both by D -flatness and F -flatness conditions. There are two classes of solutions to these conditions. The first gives a Coulomb phase similar to that of the previous section, with

$$\langle \phi \rangle \neq 0 \quad \langle Q \rangle = \langle \bar{Q} \rangle = 0. \quad (139)$$

The second gives a Higgs phase with

$$\langle \phi \rangle = 0 \quad \langle Q \rangle = \langle \bar{Q}^\dagger \rangle \neq 0. \quad (140)$$

In these lectures, I will only discuss the properties of the Coulomb phase. The behavior of the Coulomb phase in all four possible cases, $N_f = 1, 2, 3, 4$, was worked out by Seiberg and Witten.³

To analyze the Coulomb phase, we must work out the global symmetries of the theory. For a general $SU(N_c)$ gauge group, the theory has the continuous global symmetry of supersymmetric QCD, $SU(N_f) \times SU(N_f) \times U_B(1) \times U_R(1)$ (where the last factor is the anomaly-free R), broken by the superpotential coupling (137) to $SU(N_f) \times U_B(1)$. If the gauge group is $SU(2)$, however, there is additional symmetry because the spinor of $SU(2)$ is a real representation, equivalent to its conjugate. For this case, the continuous global symmetry of supersymmetric QCD is $SU(2N_f) \times U_R(1)$. Since an $SU(2)$ vector couples to two spinors in the symmetric combination, the coupling (137) preserves an $SO(2N_f)$ subgroup of this group.

If we wish to generalize the analysis of the previous section, it will also be interesting to understand the anomalous global symmetry corresponding to the phase rotation

$$\phi \rightarrow e^{i\alpha} \phi, \text{ or } u \rightarrow e^{2i\alpha} u. \quad (141)$$

To preserve the superpotential (137), this rotation must be carried out together with

$$Q \rightarrow e^{-i\alpha/2} Q \quad \bar{Q} \rightarrow e^{-i\alpha/2} \bar{Q}. \quad (142)$$

The rotations (141) and (142) together give a symmetry of classical $N = 2$ Yang-Mills theory. In the quantum theory, the anomaly generates a shift of θ or τ . When we include the effect of (142), our previous relation (89) is shifted to

$$\theta \rightarrow \theta - (4 - N_f)\alpha, \quad \text{or} \quad \tau \rightarrow \tau - \frac{4 - N_f}{2\pi} \alpha. \quad (143)$$

This transformation is an exact discrete symmetry of the theory when τ is shifted by an integer. Thus, the action of this symmetry on u gives a Z_2 symmetry for $N_f = 0$, a Z_3 symmetry for $N_f = 1$, and a Z_2 symmetry for $N_f = 2$. For $N_f = 4$, the full $U(1)$ symmetry is present, as should be expected for a theory with β function equal to zero.

From the β function (138), we can deduce the behavior of $\tau(u)$ in the weak-coupling region at large u . Analogously to (105), we find

$$\tau(u) = \frac{i}{4\pi} (4 - N_f) \log \frac{u}{\Lambda^2} . \quad (144)$$

Following the logic of Section 5.2, we find for this case the monodromy matrix at infinity

$$M_\infty = \begin{pmatrix} -1 & \frac{1}{2}(4 - N_f) \\ 0 & -1 \end{pmatrix} . \quad (145)$$

This formula is somewhat awkward to use for the cases in which the matrix elements of M are not integers. For this reason, Seiberg and Witten change their conventions for this case and define a rescaled τ and \mathbf{a}_D ,

$$\tau = 2\tau , \quad \mathbf{a}_D = 2a_D . \quad (146)$$

Then

$$\tau = \frac{i}{2\pi} (4 - N_f) \log \frac{u}{\Lambda^2} \quad (147)$$

and the new doublet (a, \mathbf{a}_D) has monodromy

$$M_\infty = \begin{pmatrix} -1 & (4 - N_f) \\ 0 & -1 \end{pmatrix} . \quad (148)$$

6.2 More about $N_f = 0$

For nonzero values of N_f , we might expect to be able to construct the effective coupling τ using the method described for $N_f = 0$ in Section 5. That is, we consider $\tau(u)$ to be the modulus of a torus. We consider the points in the u plane where this torus degenerates to be points where some particles of the theory become massless. Then we determine the geometry of the tori as a function of u by finding the analytic function $\tau(u)$ consistent with these singularities. This program is carried out in detail in ³. In these notes, I would like to focus on the cases $N_f = 1, 2$ to call attention to some interesting physical features of the solution.

As a point of reference for these cases, however, we should first rewrite the solution for $N_f = 0$ in the new notation. For $N_f = 0$, τ goes through

$$\tau \rightarrow \tau - 4 \quad (149)$$

as $u \rightarrow e^{2\pi i} u$. Thus, the τ plane is a double cover of the u plane and also of the shaded region in Figure 7. Seiberg and Witten suggest that we can parametrize these tori by writing, instead of (128), the family of cubic polynomials

$$y^2 = x^3 - ux^2 + \frac{1}{4} \Lambda^4 x ; \quad (150)$$

where I have $u_0 = \Lambda^2$. Since the magnitude of u_0 is given by the nonperturbative scale of the theory, the quantity Λ^2 defined in this way is equal to that in (144) up to an overall constant. This notation will be useful to us when we study the decoupling relation of the solutions for different values of N_f .

To see that this new family of cubics gives the same physics as (128), we should study its singularities. The cubic (150) has its zeros at

$$x = 0 , \quad x = x_{\pm} = \frac{1}{2} \left(u - \sqrt{u^2 - \Lambda^4} \right) . \quad (151)$$

Define z_1 and z_2 as in (130) where the contours C_1 and C_2 wrap around $(0, x_-)$ and (x_-, x_+) , respectively, in the manner indicated in Figure 6. The singular tori occur where pairs of zeros (151) coincide. This happens at $u = \pm \Lambda^2$ (that is, at $u = \pm u_0$), and at $u = \infty$. As $u \rightarrow \infty$, it is easy to directly evaluate the integrals and see that the formula $\tau = z_2/z_1$ reproduces (147) with $N_f = 0$. In particular,

$$z_2 \sim 2i \int_{\Lambda^4/4u}^u \frac{dx}{x} \frac{1}{\sqrt{u}} \sim \frac{2i}{\sqrt{u}} \cdot 2 \log \frac{u}{\Lambda^2} ; \quad (152)$$

this accounts for the extra factor of 2 in τ . As u makes a complete circle around the point Λ^2 , one can observe that the two zeros x_{\pm} exchange places. By playing with the contours, it is not hard to see that this leads to the monodromy

$$a \rightarrow a - \mathbf{a}_D , \quad \mathbf{a}_D \rightarrow \mathbf{a}_D . \quad (153)$$

which is the correct transcription of (120) for (\mathbf{a}_D, a) .

For the cubic (150), and for other cubics that we will encounter in this section, it is not immediately obvious which values of u correspond to singular tori. For this case, we could find these values by solving a quadratic equation. A more generally applicable procedure is to compute the *discriminant* Δ . If e_1, e_2, e_3 are the three roots of the cubic, Δ is defined by

$$\Delta = \prod_{i < j} (e_i - e_j)^2 . \quad (154)$$

On the other hand, for a cubic polynomial

$$x^3 + Bx^2 + Cx + D \quad (155)$$

it is straightforward to show that

$$\Delta = B^2C^2 - 4C^3 - 4B^3D + 18BCD - 27D^2. \quad (156)$$

For (150), we find $\Delta = (u^2 - \Lambda^4)\Lambda^8/16$. The singular tori occur where two zeros of the cubic collide, that is, at the zeros of $\Delta(u)$. Thus, the discriminant easily picks out the singularities at $u = \pm\Lambda^2$ found above.

6.3 The tori for $N_f = 1, 2$

In this section, I will review the generalization of the structure just described for $N_f = 0$ to nonzero N_f . I will work through explicitly the two simplest cases, $N_f = 1$ and 2.

As a step toward generalizing to nonzero N_f , consider first the consequence of adding massive matter fields to the theory. Hypermultiplets of $N = 2$ Yang-Mills theory can receive mass from a superpotential term

$$\Delta W = m_i \bar{Q}_i Q_i \quad (157)$$

which preserves the full supersymmetry. When all of the mass parameters m_i are large, we must recover the $N_f = 0$ solution for $\tau(u)$ just discussed. On the other hand, $\tau(u)$ must depend holomorphically on the m_i . So it is natural that, for N_f nonzero, the effective coupling $\tau(u)$ is still the modulus of a torus whose geometry is a holomorphic function of u and the m_i .

We can identify these tori by constructing the associated cubic polynomials $y(x)$. The $U(1)$ symmetry (141) provides a useful tool in constructing these polynomials. So far in this discussion, we have been thinking of this transformation as an anomalous global symmetry. However, as in Section 4, we can supplement this transformation by a shift of the theta parameter, $\tau \rightarrow \tau + (4 - N_f)\alpha/2\pi$ and consider it as an exact global $U(1)$ symmetry. Under this transformation, u has charge 2 and Λ^{b_0} has charge $(4 - N - f)$, giving Λ charge 1 for any N_f . The cubic $y(x)$ should have a definite transformation property under this symmetry. In fact, the following set of charge assignments make the $N_f = 0$ cubic (150) covariant under this $U(1)$:

$$u : 2, \quad \Lambda : 1, \quad x : 2, \quad y : 3. \quad (158)$$

If we obtain the $N_f = 0$ torus from a torus with nonzero N_f by holomorphic decoupling, and we are careful to give masses to the matter fields in a way

that preserves the $U(1)$ symmetry, we should expect these charge assignments to hold for the tori we will find for nonzero N_f . The $U(1)$ symmetry will be respected by the mass terms if the masses m_i are assigned a charge which compensates the rotation (142), that is

$$m_i : 1 . \quad (159)$$

For very large values of u , τ must have the asymptotic behavior (144). It is interesting to ask how the $N_f = 0$ solution joins on to this behavior. Consider the situation in which all of the m_i are much greater than the effective Λ of the theory with the matter fields decoupled. Then for $\Lambda^2 \ll |u| \ll m_i^2$, τ will have the singularity (149). However, at large values of u we encounter a new singularity. The full superpotential for the i th flavor is

$$\Delta W = m_i \bar{Q}_i Q_i + 2 \bar{Q}_i \phi^{at} Q_i , \quad (160)$$

so that when $\langle \phi^3 \rangle = \mp m_i$ or $u = m_i^2$, a pair of matter fields has zero mass. Since these massless fields are charged under the unbroken $U(1)$ gauge symmetry, they renormalize the effective coupling toward zero. In fact, we find that, near this point,

$$\tau \sim \frac{i}{2\pi} \log \frac{u - 2m_i^2}{\Lambda^2} . \quad (161)$$

For larger values of $|u|$, τ shifts by one fewer unit as the phase of u goes from 0 to 2π . In a theory with N_f flavors of massive matter fields, we will eventually pass N_f of these singularities and recover the asymptotic behavior (149).

A similar effect occurs when we consider the decoupling of a single flavor from a theory with nonzero N_f . Consider, for definiteness, the theory with $N_f = 2$. Asymptotically in u , τ shifts by 2 units as the phase of u is increased from 0 to 2π . However, if one flavor is light and one is heavy, we find the situation shown in Figure 8. At small values of u , there is a region which exhibits strong-coupling dynamics. When u is carried around this region, τ shifts by 3 units. At large u , there is an additional singularity which changes the shift in τ to the step of 2 units required by (149).

With this orientation, we can try to obtain the family of tori which describe the theory for $N_f = 2$ massless flavors. By decoupling the two flavors one at a time, we should obtain the $N_f = 1$ and $N_f = 0$ theories.

The problem of finding the tori of $N_f = 2$ has several features in common with the problem we solved in the previous section for $N_f = 0$. The theory has a Z_2 symmetry acting in u . The behavior of τ at infinity is just that which we required for τ in (105).

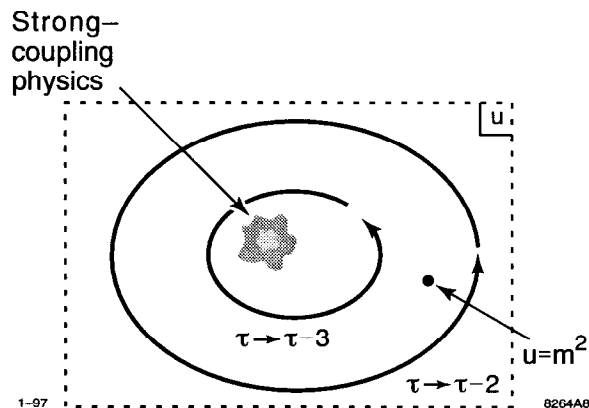

Figure 8: Monodromy of τ in the weak-coupling region for a theory with a large mass m for one flavor.

We can try to find strong-coupling singularities of $\tau(u)$ associated with the magnetic monopoles of the theory coming down to zero mass. The global symmetry of the theory is $SO(4) = SU(2) \times SU(2)$. The monopoles have zero modes for the fermionic partners of Q_i and \bar{Q}_i ; when we consider the multiplet of states in which these zero modes are filled or empty, the monopoles form spinor representations of the global symmetry group. The monopoles with even electric charge become $(2, 1)$ multiplets of $SU(2) \times SU(2)$; the monopoles with odd electric charge become $(1, 2)$ multiplets. The simplest Z_2 -invariant set of singularities is one in which a $(2, 1)$ multiplet of monopoles becomes massless at $u = \Lambda^2$ and a $(1, 2)$ multiplet becomes massless at $u = -\Lambda^2$. Since two pairs of monopoles are becoming massless at each of these points, we find a singularity in τ twice as strong as that in (112),

$$-\frac{1}{\tau(u)} = -\frac{1}{2\tau(u)} = \frac{-i}{\pi} \log(u - u_0) . \quad (162)$$

From this data, we see that the requirements on the function $\tau(u)$ for $N_f = 2$ are precisely those which we found in the previous section for $\tau(u)$ in the case $N_f = 0$. Thus, the effective coupling constant τ in this case is given by the family of tori associated with

$$y^2 = (x - \Lambda^2)(x + \Lambda^2)(x - u) , \quad (163)$$

just as in Section 5.4. Notice that, with the $U(1)$ charge assignments given

in (158), this polynomial transforms covariantly with charge 6, as we would expect.

From this solution for $N_f = 2$, we can decouple one flavor to find the solution for $N_f = 1$. First of all, we must determine how the mass perturbation affects the polynomial (163). For small m_2 (and so, formally, for all m_2), the mass of a matter field does not affect the coupling constant renormalization in perturbation theory. This mass can enter, however, through nonperturbative corrections. For small m_i , these are given by instanton effects. According to (73), each instanton brings with it a power of Λ^{b_0} . For $N_f = 2$, the one-instanton amplitude is zero unless we saturate the zero modes by supplying masses for both flavors. Thus, the leading effect comes from a 2-instanton contribution. This term is proportional to $m_2^2 \Lambda^4$, and this term saturates the allowed $U(1)$ charge. Thus, the most general cubic possible for the $N_f = 2$ theory with one massive flavor is

$$y^2 = (x - \Lambda^2)(x + \Lambda^2)(x - u) - cm_2^2 \Lambda^4. \quad (164)$$

where c is a constant to be determined. This constant can be fixed in the following way. We have argued that, when $m_2 \gg \Lambda$, we must find a singular torus when $u = m_2^2$. The discriminant of (164) is given by

$$\Delta = (u - cm_2^2)(4u^3 \Lambda^4 - 27(u - cm_2^2)\Lambda^8) + \dots, \quad (165)$$

where the omitted terms are negligible for $m_2 \gg \Lambda$. Thus, we find a singular torus for $u = cm_2^2$ and no other singularities except in the region $u \sim \Lambda^2$. This implies that $c = 1$.

Having now determined the polynomial for $N_f = 2$ and one flavor massive, we can find the polynomial for $N_f = 1$ by holomorphic decoupling. Take $m_2 \rightarrow \infty$, while keeping the Λ parameter of the effective 1-flavor theory fixed. According to (70), this is given by

$$(\Lambda^3)_{\text{eff}, N_f=1} = m_2 (\Lambda^2)_{N_f}, \quad (166)$$

so we must take $\Lambda \rightarrow 0$ as $m_2 \rightarrow \infty$ in such a way that the right-hand side of (166) is fixed. Then, the family of tori for $N_f = 1$ are given by

$$y^2 = x^2(x - u) - \Lambda^6, \quad (167)$$

where I have written the new effective QCD scale simply as Λ .

As a first check, the formula (167) has the correct $U(1)$ charge. To understand this polynomial more fully, we might compute its discriminant:

$$\Delta = -4u^3 \Lambda^6 - 27 \Lambda^{12}. \quad (168)$$

Pairs of zeros collide when

$$u = \left(-\frac{27}{4} \Lambda^6 \right)^{1/3} . \quad (169)$$

There are three cube roots, and so we find three singularities in a Z_3 -symmetric pattern. This realizes the Z_3 symmetry that we predicted below (143).

Another check of (167) is given by decoupling the remaining flavor. If we wish to add to (167) a term proportional to one power of m_1 and one instanton factor Λ^3 in a way consistent with the $U(1)$ symmetry, the only possibility is

$$y^2 = x^2(x - u) - \Lambda^6 - m\Lambda^3(ax + bu) , \quad (170)$$

where a and b are to be determined. Note that higher powers of $(m\Lambda^3)$ have a $U(1)$ charge higher than 6. Computing the discriminant, we can see that there is a singular point at $u = m_1^2$ only if $a = 2$ and $b = 0$. Then the polynomial corresponding to $N_f = 1$ with a nonzero mass is

$$y^2 = x^2(x - u) - \Lambda^6 - 2m\Lambda^3 x . \quad (171)$$

If we let $m_1 \rightarrow \infty$, we find a theory with zero flavors and the effective QCD parameter

$$(\Lambda^4)_{\text{eff},0} = m_2 (\Lambda^3)_1 . \quad (172)$$

The polynomial which characterizes this situation is

$$y^2 = x^2(x - u) - 2\Lambda^4 x . \quad (173)$$

which agrees with (150) after a permitted constant rescaling of Λ .

Now that we understand the transition from the $N_f = 2$ theory to the $N_f = 1$ theory at a technical level, it is worth thinking a bit more about the physics of this transition. In each of these problems, the effective coupling has singularities at specific points in the moduli space of u where magnetic monopoles become massless. In the $N_f = 2$ theory, there were two such points, at each of which two monopole-antimonopole pairs become massless. In the $N_f = 1$ theory, there were three points, at each of which one monopole-antimonopole pair becomes massless. As in the $N_f = 0$ cases analyzed in the previous section, the monopoles which become massless at each point differ in their electric charges. In the $N_f = 1$ case, where τ goes through 3 units as u increases its phase by 2π , the monopoles which become massless are those which begin at u real with the electric charges 0, 1, 2.

The transition from the set of u -plane singularities for $N_f = 2$ to that for $N_f = 1$ is shown in Figure 9. Something strange is happening here. At zero

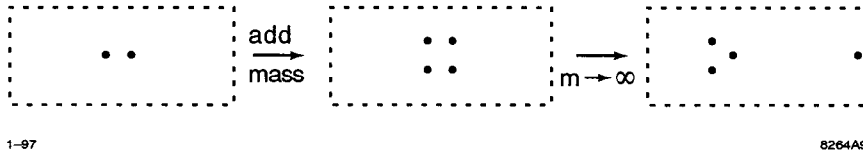

Figure 9: Motion of the singularities of $\tau(u)$ for the Seiberg-Witten model with $N_f = 2$ as a mass m is turned on for one flavor.

mass, we have two singularities in Z_2 -symmetric locations. Under a small mass perturbation, these break up into four singularities, each of which corresponds to a point where one monopole-antimonopole pair becomes massless. As the mass is increased, one of these points runs out to infinity, while the other three organize themselves into the Z_3 -symmetric structure required for $N_f = 1$. But when the fourth singularity comes out into the weak-coupling region, it has the interpretation of a point at which an elementary matter field becomes massless. So apparently, we can pass continuously, in the Seiberg-Witten solution, between solitons of the theory and elementary particles. This is an extreme, but perfectly permissible, example of the continuous connection of phases which would seem to be distinguished qualitatively.

The $N_f = 1$ theory has one more very interesting feature. Starting from (167), take the limit $\Lambda \rightarrow 0$. The three points where monopole pairs become massless then approach one another and coalesce. We obtain a theory with a singularity at $u = 0$ at which monopoles with electric charge 0, 1, and 2 simultaneously become massless. This is a quite unusual situation, because these three species are mutually nonlocal. This general situation, in which nonlocal species are simultaneously massless, is called an *Argyres-Douglas point*.⁴¹ The particular points of this type in $N = 2$ $SU(2)$ Yang-Mills theory have been analyzed in detail by Argyres, Plesser, Seiberg, and Witten,⁴² who give evidence that they are new nontrivial scale-invariant field theories and compute some of the scaling dimensions of operators.

There is one more aspect of the $SU(2)$ gauge theories which I have no space to discuss here. For the case $N_f = 4$, the β function of the theory vanishes. This case would then have zero coupling constant renormalization and might also be expected to have exact strong-weak-coupling duality (' S -duality'). Seiberg and Witten argue that this case can be described by a family of tori described by a cubic which transforms covariantly under the $SL(2, Z)$ S -duality group.³ More concretely, they find

$$y^2 = 4x^3 - g_2(\tau)x - g_3(\tau). \quad (174)$$

where g_2 and g_3 are the unique modular forms of weights 4 and 6 under $SL(2, Z)$. I refer you to their paper for a detailed discussion of the S -duality and for a demonstration that this formula implies all of those given above by holomorphic decoupling.

Unfortunately, there are still some lingering questions about the $N = 2$ $SU(2)$ Yang-Mills theories. For the case $N_f = 3$, the general arguments that I have given in this section fix the family of tori only up to one undetermined constant, which eventually was fixed by an explicit two-instanton computation.^{39,40} For $N_f = 4$, it turned out that the explicit formula (174) was incompatible with the result of a similar two-instanton calculation. Presumably, this is evidence that the coupling constant definition used in this calculation, the Pauli-Villars prescription, is not invariant under S -duality. The Pauli-Villars coupling would then be related to the coupling constant definition used by Seiberg and Witten by an arbitrary function of τ . It would be strange and remarkable if S -duality could be exact in field theory only with the string theory regulator. The precise resolution of this confusion, though, is still not clear.

6.4 Larger gauge groups

To conclude this section, I would like to comment briefly on the generalization of the Seiberg-Witten theory to larger gauge groups.

The same analysis that predicted a Coulomb phase of the $SU(2)$ gauge theory applies to any gauge group. Quite generally, we find a vacuum state of the classical theory by solving the D -flatness condition (86). The matrix $\langle \phi \rangle$ can be diagonalized; for example, for $G_c = SU(N_c)$ we have

$$\langle \phi \rangle = \begin{pmatrix} \phi_1 & & \\ & \ddots & \\ & & \phi_{N_c} \end{pmatrix}, \quad (175)$$

where $\phi_1, \dots, \phi_{N_c}$ are complex parameters such that $\sum_i \phi_i = 0$. At a generic point where no pair of the ϕ_i are equal, this expectation value breaks the gauge group G_c down to $(U(1))^r$, where r is the rank of G . For the case of $SU(N_c)$, we find a product of $(N_c - 1)$ $U(1)$ gauge groups. These vacua remain supersymmetric minima in the quantum theory. They are described by the effective Lagrangian

$$\mathcal{L}_{\text{eff}} = \frac{-i}{16\pi} \int d^2\theta \tau^{ij}(\phi) \mathcal{W}^{\alpha i} \mathcal{W}_\alpha^j + h.c., \quad (176)$$

where i, j are summed over $1, \dots, r$. The effective couplings form an $r \times r$ matrix, which depends on gauge-invariant functions of ϕ . If we gauge-fix to

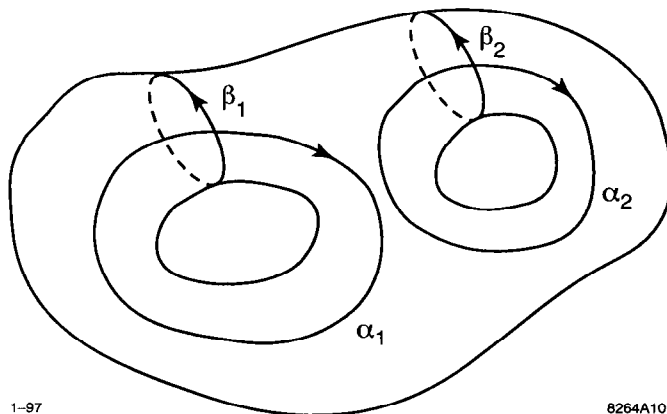

Figure 10: Complementary cycles on a surface of genus 2.

configurations of the form (175), τ must still be invariant under all permutations of the eigenvalues ϕ_i . If the gauge boson kinetic energy term in (176) is to be positive, the matrix τ must satisfy

$$\text{Im } \tau > 0 \quad (177)$$

as a matrix.

This condition is naturally satisfied if τ is the *period matrix* of a 2-dimensional surface of genus $g = r$. This object is defined as follows. A surface of genus g can be characterized by pairs of complementary cycles α_i, β_i , $i = 1, \dots, g$, as shown in Figure 10. Alternatively, such a surface can be characterized by g independent holomorphic differentials λ_ℓ . These objects have a complementary relation; the differential λ_i integrated around the cycle α_i or β_i gives a nonzero result. More generally, define

$$A_\ell^i = \oint_{\alpha_i} \lambda_\ell \quad B_{j\ell} = \oint_{\beta_j} \lambda_\ell. \quad (178)$$

Then the period matrix of the genus g surface is given by

$$\tau = B A^{-1}. \quad (179)$$

This generalizes the formula (131) for the modulus τ of a torus.

The most direct generalization of the construction in Section 5.4 would

associate τ with a 2-dimensional surface defined by an integral

$$z = \int_{x_0}^x \frac{dx}{y}, \quad (180)$$

where $y^2(x)$ is a polynomial. If this polynomial has degree $n = 2g + 2$, $y(x)$ is a double-sheeted surface with $(g + 1)$ branch cuts; this is a surface of genus g . (It is equivalent to write a polynomial of degree $n = 2g + 1$; this puts one branch point at ∞ .)

A surface constructed in this way is called 'hyperelliptic'. All surfaces of genus 1 and 2 are equivalent to hyperelliptic surfaces by general coordinate and conformal transformations, but the set of hyperelliptic surfaces is a smaller and smaller subspace of the space of all 2-dimensional surfaces at higher genus.

Nevertheless, it was shown by Argyres and Faraggi⁴³ and by Klemm, Lerche, Thiesen, and Yankielowicz⁴⁴ that the Seiberg-Witten problem for more general gauge groups is solved by a particular class of hyperelliptic surfaces. For $G_c = SU(N_c)$, these surfaces can be constructed easily by generalizing the $U(1)$ symmetry described in (158). For the $N = 2$ $SU(N_c)$ gauge theory with N_f flavors of hypermultiplets in the fundamental representation, the $U(1)$ symmetry of the theory is

$$\phi \rightarrow e^{i\alpha} \phi, \quad \tau \rightarrow \tau + (2N_c - N_f)\alpha/2\pi. \quad (181)$$

Since the first β function coefficient is given by $b_0 = (2N_c - N_f)$, we find from (40) that Λ has charge 1. The one-instanton amplitude is proportional to $\Lambda^{2N_c - N_f}$.

Consider first the pure $N = 2$ $SU(N_c)$ gauge theory, $N_f = 0$. Introduce a variable x with charge 1 under the $U(1)$ symmetry. (This is effectively the square root of x in Section 6.2.) Then consider the polynomial

$$y^2 = \prod_i (x - \phi_i)^2 - \Lambda^{2N_c}. \quad (182)$$

This object is covariant under the $U(1)$ and totally symmetric in the ϕ_i . The QCD scale Λ enters as the one-instanton factor. Thus, it is a reasonable candidate for the polynomial we are seeking. For the case $SU(2)$, we may set $\phi_1 = -\phi_2 = \phi$, with $\phi^2 = u$. Then (182) takes the form

$$\begin{aligned} y^2 &= (x^2 - \phi^2)^2 - \Lambda^4 \\ &= (x + \sqrt{u + \Lambda^2})(x - \sqrt{u + \Lambda^2})(x + \sqrt{u - \Lambda^2})(x - \sqrt{u - \Lambda^2}). \end{aligned} \quad (183)$$

The pairs of zeros coalesce at $u = \pm\Lambda^2, \infty$. This is in fact another representation of the family of tori discussed in Section 5. For more general $SU(N_c)$

groups, it is not difficult to check that (182) has the correct decoupling limit near points in the moduli space where an $SU(2)$ subgroup of the gauge group is manifest at low energy. If the vacuum expectation value of ϕ preserves an approximate $SU(2)$ symmetry, then two eigenvalues of ϕ are almost equal. Call these $i = 1, 2$ and write

$$\phi_i = \phi + \chi, \quad \phi_2 = \phi - \chi, \quad \hat{x} = x - \phi. \quad (184)$$

Then (183) becomes

$$y^2 = (\hat{x}^2 - \chi^2) \prod_{i>2} (\phi - \phi_i)^2 - \Lambda^{2N_c}. \quad (185)$$

The factors $(\phi - \phi_i)^2$ are the vacuum expectation value which give mass to the off-diagonal vector bosons when $SU(N_c)$ is broken to $SU(2)$. Using the analogue of the relation (62), we can write this equation in the form (183) in terms of the effective Λ parameter of the $SU(2)$ theory. Additional checks of the formula (182) are given in ^{43,44}.

The analogous polynomial representing the family of surfaces for the Coulomb phase of $SU(N_c)$ Yang-Mills theory with N_f flavors, $N_f \leq N_c$, is ^{45,46,47}

$$y^2 = \prod_i (x - \phi_i)^2 - \Lambda^{2N_c - N_f} \prod_f (x - m_j), \quad (186)$$

where $i = 1, \dots, N_c$ and $j = 1, \dots, N_f$. The term proportional to one power of each mass m_j is also proportional to the one-instanton factor. The full expression (186) returns to (181) when we decouple the massive hypermultiplets. For $N_f > N_c$, there are additional ambiguities of the type discussed above for $SU(2)$ gauge theories with $N_f = 3$ and 4.

In the moduli space of larger $SU(N_c)$ gauge groups, there are many families of magnetic monopoles, and thus there are many opportunities for Argyres-Douglas points where mutually nonlocal species becomes simultaneously massless. The original example of Argyres and Douglas was given for the case of $SU(3)$.⁴¹

Finally, I should note that the Seiberg-Witten construction appears in a natural way in considerations of superstring duality. Kachru and Vafa⁴⁸ considered examples of heterotic string compactifications on $K3 \times T^2$. These theories have $N = 2$ space-time supersymmetry, and one can find examples which give rise to effective $SU(2)$ Yang-Mills theories at low energies. These theories are dual to Type IIA theories compactified on certain Calabi-Yau manifolds. And, indeed, the dual theory exhibits the moduli space of the Seiberg-Witten model. The systematics of this phenomenon has been explored

further in ^{49,50}. A review of this set of developments has been given in ⁵¹. More recently, Sen⁵² and Banks, Douglas, and Seiberg⁵³ have shown that the Seiberg-Witten moduli space arises also from the consistency conditions for embedding 3-branes in well-chosen Type IIB compactifications.

7 Seiberg's Non-Abelian Duality

In Section 4, I discussed the behavior of strongly-coupled supersymmetric $SU(N_c)$ Yang-Mills theory for values of the number of flavors N_f from 0 to N_c . It is now time that we returned to this theory and continue to explore its properties, considering still larger numbers of flavors. Seiberg found a compelling picture for the behavior of supersymmetric QCD in this regime.⁴ This picture includes a region in which the non-Abelian gauge symmetry is unbroken but nevertheless is realized in a Coulomb phase. Seiberg argued that this region is dual to a similar non-Abelian Coulomb phase of a different $SU(N_c)$ gauge theory, thus generalizing the familiar Abelian electric-magnetic duality.

7.1 More about $N_f = N_c$

To extend the picture of Section 4 to higher values of N_f , I would like to begin by clarifying one aspect of the physical picture for $N_f = N_c$ which we discussed in Section 4.5. I argued there that, in this case, supersymmetric QCD had a manifold of degenerate, supersymmetric vacuum states. These vacua were parametrized by the gauge-invariant fields T , B , and \bar{B} , subject to the Seiberg's constraint (80). Oscillations of the scalar components of these fields which satisfy the constraint correspond to local fluctuations along the manifold of vacuum states. Thus, they are massless composite bosons. By supersymmetry, the fermionic components of these fields are then massless composite fermions.

The question of whether relativistic fermions can be tightly bound into massless composite states is obviously a fundamental issue in quantum field theory. The question of whether massless fermionic bound states are possible is also a matter of phenomenological relevance for people who would like to construct composite models of quarks and leptons. Some time ago, 't Hooft proposed a general consistency condition on massless fermionic composite states which has turned out in practice to be very stringent.⁵⁴ I would now like to introduce 't Hooft's criterion and then check whether it is satisfied by the physical picture we have built for supersymmetric QCD with $N_f = N_c$.

Consider, then, a Yang-Mills theory with gauge group G_c coupled to some matter fields. Let the continuous global symmetry of this theory be G . Let

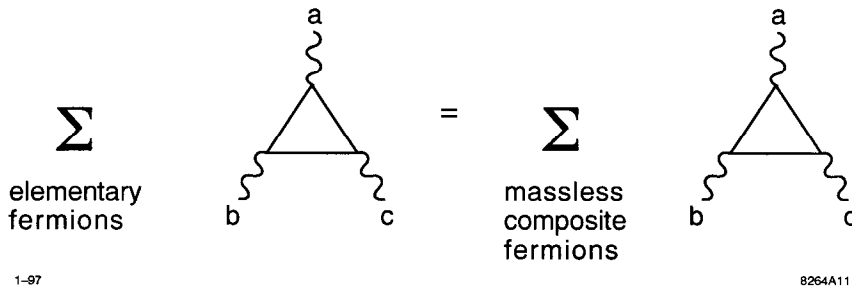

Figure 11: The 't Hooft anomaly matching condition.

$J_\mu^a, J_\mu^b, J_\mu^c$ be three currents of the global symmetry. Typically, the product of these currents will have a nonzero axial vector anomaly, which can be evaluated at short distances by computing the triangle diagram of the three currents, summed over all elementary matter fermions in the loop. When we consider the theory at low energies, the three corresponding symmetries may be spontaneously broken, or they may be exact symmetries of the vacuum. If they are exact symmetries, we can assign the massless particles in the theory definite quantum numbers under these symmetries, and we can compute the triangle diagram summing over the massless fermions of the effective low-energy theory. 't Hooft claimed that the anomaly computed in this way must agree with the anomaly obtained from the short-distance calculation using the elementary fields. This is the *'t Hooft anomaly matching condition*. The condition is illustrated in Figure 11.

The proof of this condition given by 't Hooft is very simple. Add to the theory weakly-coupled vector bosons which gauge the global symmetry G , and add massless fermions which are neutral under G_s (call them 'leptons') as necessary to cancel the G gauge anomalies. We have now defined a consistent gauge theory. The effective theory at low energies should also be a consistent gauge theory of G . But in this theory, the 'leptons' have the same nonzero G anomalies, and these must be cancelled by contributions of the physical massless fermions arising from the G_s theory at low energy. Note that *massive* fermions must be vectorlike under unbroken global symmetries, so these do not contribute at all to anomaly matching. A more formal proof of the anomaly matching condition, which uses dispersion relations to connect the low- and high-energy evaluations of the anomaly, has been given in⁵⁵.

Since our picture of the the behavior of supersymmetric QCD with $N_f = N_c$ contains massless composite fermions, it can only be consistent if these

satisfy the 't Hooft anomaly condition. The original global symmetry of the model is

$$G = SU(N_f) \times SU(N_f) \times U_B(1) \times U_R(1), \quad (187)$$

In this section, the symbol R will always refer to the anomaly-free R symmetry (49); however, for $N_f = N_c$, this coincides with the canonical R symmetry. At a typical point in the moduli space, however, this symmetry is broken all the way to $U_R(1)$ by vacuum expectation values of the fields T , B , and \bar{B} . But there are certain special points of maximal symmetry where a large part of G remains unbroken. At these points, the 't Hooft condition is especially strong.

One set of expectation values which satisfies the constraint (80) and leads to a point of maximal symmetry is: $T = \Lambda^2 \cdot 1$, $B = \bar{B} = 0$. At this point, G is broken to

$$SU(N_f) \times U_B(1) \times U_R(1). \quad (188)$$

Under this subgroup, the elementary fermions have the quantum numbers:

$$\psi_Q : (N_f)_{1,-1} \quad \psi_{\bar{Q}} : (\bar{N}_f)_{-1,-1} \quad \lambda : (1)_{0,+1}. \quad (189)$$

Among the composite fermions, we may eliminate the superpartner of $\text{tr} T$ using the constraint (80). The remaining fermionic partners ψ_T form an adjoint representation of $SU(N_f)$. The quantum numbers of the physical composite fermions under (188) are then

$$\psi_T : (N_f^2 - 1)_{0,-1} \quad \psi_B : (1)_{N_f,-1} \quad \psi_{\bar{B}} : (1)_{-N_f,-1}. \quad (190)$$

From these sets of quantum numbers, we can compute the anomaly coefficients directly. Recall the group theory coefficient $C(r)$ defined below (36) equals $\frac{1}{2}$ in the fundamental representation of $SU(N_f)$ and equals N_f in the adjoint representation. Similarly, let Ad^{abc} be the value of the anomaly of three $SU(N_f)$ currents due to a chiral fermion in the fundamental representation. Then, for example, the $(SU(N_f))^2 U_R(1)$ anomaly coefficient from the elementary fields ψ_Q and $\psi_{\bar{Q}}$ in (189) equals $2 \cdot N_c \cdot C(N_f) \cdot (-1) = -N_f$, while the anomaly coefficient from the composite fields comes only from ψ_T and equals $C(G) \cdot (-1) = -N_f$. The full set of nonvanishing anomaly coefficients in the theory is

	<i>elementary</i>	<i>composite</i>	
$(SU(N_f))^2 U_R(1) :$	$-N_f$	$-N_f$	(191)
$(U_B(1))^2 U_R(1) :$	$-2N_f$	$-2N_f$	
$(U_R(1))^3 :$	$-(N_f^2 + 1)$	$-(N_f^2 + 1)$	

I have used $N_f = N_c$. The last line is the sum of the cubes of the $U_R(1)$ charges of all of the chiral fermions. The 't Hooft argument also applies to the gravitational anomaly of $U(1)$ charges,^{5,6} and therefore we should also check that the trace of the $U_R(1)$ charge is the same in the elementary and composite fermion multiplets. This is

$$\text{tr}[U_R(1)] : \quad -(N_f^2 + 1) \quad -(N_f^2 + 1) \quad (192)$$

All of the anomalies match.

A similar check can be made at another point of maximal symmetry with a rather different unbroken gauge group. We can satisfy the constraint (80) without breaking the $SU(N_f) \times SU(N_f)$ global symmetry at the point in the moduli space given by the vacuum expectation values $T = 0$, $B = -\bar{B} = \Lambda^{N_c}$. At this point, G is broken to

$$SU(N_f) \times SU(N_f) \times U_R(1) . \quad (193)$$

Under this subgroup, the elementary fermions have the quantum numbers:

$$\psi_Q : (N_f, 1)_{-1} \quad \psi_{\bar{Q}} : (1, \bar{N}_f)_{-1} \quad \lambda : (1, 1)_{+1} . \quad (194)$$

For the composite fermions, we may use the constraint to eliminate the constraint to eliminate $\psi_{\bar{B}}$ or ψ_B . The quantum numbers of the remaining composite fermions are

$$\psi_T : (N_f, \bar{N}_f)_{-1} \quad \psi_B : (1, 1)_{-1} \quad \psi_{\bar{B}} : (1)_{-N_f, -1} . \quad (195)$$

The various anomalies can easily be found to be

	<i>elementary</i>	<i>composite</i>	
$(SU(N_f))^3 :$	AN_f	AN_f	
$(U_B(1))^2 U_R(1) :$	$-\frac{1}{2}N_f$	$-\frac{1}{2}N_f$	(196)
$\text{tr}[U_R(1)] :$	$-(N_f^2 + 1)$	$-(N_f^2 + 1)$	
$(U_R(1))^3 :$	$-(N_f^2 + 1)$	$-(N_f^2 + 1)$	

Again, the anomalies match. So Seiberg's picture of the behavior of supersymmetric QCD for $N_f = N_c$ passes this unexpected and quite nontrivial consistency condition.

7.2 $N_f = N_c + 1$

With this insight, we can move on to discuss the case $N_f = N_c + 1$. For this case, the gauge-invariant chiral superfields include T and also the baryonic superfields

$$\begin{aligned} B_i &= \epsilon_{ij_1 \dots j_{N_c}} \epsilon_{a_1 \dots a_{N_c}} Q_{j_i}^{a_1} \dots Q_{j_{N_c}}^{a_{N_c}}, \\ \bar{B}_i &= \epsilon_{ij_1 \dots j_{N_c}} \epsilon_{a_1 \dots a_{N_c}} \bar{Q}_{j_1}^{a_1} \dots \bar{Q}_{j_{N_c}}^{a_{N_c}}. \end{aligned} \quad (197)$$

where the j_i are flavor indices and the a_i are color indices. The fields B_i and \bar{B}_i transform, respectively, as a $(\bar{N}_f, 1)$ and a $(1, N_f)$ of $SU(N_f) \times SU(N_f)$.

Seiberg proposed that this system is described by the superpotential⁸²

$$W = \frac{1}{\Lambda^{b_0}} (\det T - B_i T^{ij} \bar{B}_j). \quad (198)$$

This expression is invariant under the global symmetry of the model and has charge 2 under the anomaly-free R symmetry (49).

Holomorphic decoupling provides a more stringent test. Add a mass term for the last flavor, to give the superpotential

$$W = \frac{1}{\Lambda^{b_0}} (\det T - B_i T^{ij} \bar{B}_j) + m T_{N_f N_f}. \quad (199)$$

The F -flatness conditions for $T_{N_f i}$, $T_{i N_f}$, B_i , and \bar{B}_i for $i < N_f$ reduce T , B , \bar{B} to the form

$$T = \begin{pmatrix} \tilde{T} & 0 \\ 0 & t \end{pmatrix} \quad B = \begin{pmatrix} 0 \\ B_{N_f} \end{pmatrix} \quad \bar{B} = \begin{pmatrix} 0 \\ \bar{B}_{N_f} \end{pmatrix}. \quad (200)$$

The condition $F_t = 0$ is

$$\frac{1}{\Lambda^{b_0}} (\det \tilde{T} - \tilde{B} \tilde{B}) + m = 0. \quad (201)$$

This can be rewritten as

$$\det \tilde{T} - \tilde{B} \tilde{B} = m \Lambda^{b_0} = (\Lambda^{b_0})_{\text{eff}, N_f - 1}, \quad (202)$$

where I have used the decoupling condition (70). Since, in the effective theory with $N_f = N_c$, $b_0 = 2N_c$, this is precisely the constraint (80). Thus, the effective description of this case as a moduli space of vacua parametrized by T , B , \bar{B} , subject to the equations of motion following from the superpotential

(198), does connect correctly to our descriptions of supersymmetric QCD for smaller numbers of flavors.

The precise description of the moduli space of vacuum states is given by solving the F -flatness conditions which follow from (198). These are

$$T \cdot \bar{B} = B \cdot T = 0 \quad \det T(T^{-1})^{ij} = B^i \bar{B}^j . \quad (203)$$

Notice that the point $T = B = \bar{B} = 0$ satisfies these conditions, and so there is a point in the moduli space where the full global symmetry

$$SU(N_f) \times SU(N_f) \times U_B(1) \times U_R(1) \quad (204)$$

is preserved. At this point, the 't Hooft anomaly conditions provide an especially stringent check of the analysis.

The quantum numbers of the elementary fermions of the theory are

$$\psi_Q : (N_f, 1)_{1, -1+1/N_f} \quad \psi_{\bar{Q}} : (1, \bar{N}_f)_{-1, -1+1/N_f} \quad \lambda : (1, 1)_{0, +1} . \quad (205)$$

Note that the $U_R(1)$ quantum numbers are those of the anomaly-free R symmetry (49). At the point of maximal symmetry, the composite fermions have the quantum numbers

$$\psi_T : (N_f, \bar{N}_f)_{0, -1+2/N_f} \quad \psi_B : (\bar{N}_f, 1)_{N_c, -1/N_f} \quad \psi_{\bar{B}} : (1, N_f)_{N_c, -1/N_f} \quad (206)$$

You can readily check that the anomaly coefficients due to these representations are the following:

	<i>elementary</i>	<i>composite</i>
$(SU(N_f))^3 :$	AN_c	AN_c
$(SU_L(N_f))^2 U_B(1) :$	$\frac{1}{2}N_c$	$\frac{1}{2}N_c$
$(SU_L(N_f))^2 U_R(1) :$	$-\frac{1}{2}N_c^2/N_f$	$-\frac{1}{2}N_c^2/N_f$
$(U_B(1))^2 U_R(1) :$	$-2N_c^2$	$-2N_c^2$
$\text{tr}[U_R(1)] :$	$-N_f^2 + 2N_f - 2$	$-N_f^2 + 2N_f - 2$
$(U_r(1))^3 :$	$N_f(N_f - 2) - 2N_c^4/N_f^2$	$N_f(N_f - 2) - 2N_c^4/N_f^2$

(207)

where, in all of the lines, it is necessary to use the relation $N_c = (N_f - 1)$. The last line of the table is especially tedious to verify, but all of the anomalies do match, providing a remarkable consistency check on the physical picture.

The picture of the vacuum states of supersymmetric QCD that we have constructed for $N_f = N_c + 1$ has an obvious generalization for higher values of N_f . The gauge-invariant chiral superfields of the theory are

$$T^{ij} \quad B_{ij\dots k} \quad \overline{B}_{ij\dots k} . \quad (208)$$

Here $B_{ij\dots k}$ is the baryon superfield, build as a product of N_c quark superfields, which contains all flavors except $ij\dots k$, and \overline{B} is defined in a similar way. An $SU(N_f) \times SU(N_f)$ -invariant superpotential is given by

$$W \sim \left(\det T - B_{ij\dots k} T^{i\bar{i}} T^{j\bar{j}} \dots T^{k\bar{k}} \overline{B}_{ij\dots\bar{k}} \right) . \quad (209)$$

However, this superpotential does not have R charge equal to 2, and the multiplet of fields (T, B, \overline{B}) does not satisfy the 't Hooft anomaly conditions for the unbroken gauge group. In fact, since the anomaly of the flavor representation with p indices grows as N_f^{p-1} , the mismatch of the 't Hooft conditions grows worse with each successive number of flavors. We need a better idea.

7.3 Seiberg's dual QCD

Seiberg addressed this challenge in the following way: The baryon superfields in (208) have

$$\tilde{N}_c = N_f - N_c \quad (210)$$

indices. Thus, we can view these fields as bound states of \tilde{N}_c components. Let us assume that these components are the physical asymptotic states of the theory. We can associate these components with new superfields q and \bar{q} . To bind these constituents into the gauge-invariant baryon superfields, we need a Yang-Mills theory with gauge group $SU(\tilde{N}_c)$, for which the q and \bar{q} transform in the fundamental and antifundamental representations. Then the baryon superfields would have the dual description

$$B_{ij\dots k} = \epsilon_{a_1\dots a_{\tilde{N}_c}} q_i^{a_1} q_j^{a_2} \dots q_k^{a_{\tilde{N}_c}} , \quad (211)$$

and similarly for \overline{B} .

The complete proposal put forward by Seiberg is that supersymmetric QCD with N_f flavors can be described, for $N_f > N_c + 1$, by a supersymmetric Yang-Mills theory with gauge group $SU(\tilde{N}_c)$ coupled to the chiral fields q_i and \bar{q}_i , $i = 1, \dots, N_f$, and an additional chiral supermultiplet T^{ij} , which is a gauge singlet. The field T couples to q and \bar{q} through the superpotential

$$W = q T \bar{q} . \quad (212)$$

Without the superpotential, the theory has an additional $U(1)$ global symmetry which acts on T ; however, this symmetry is broken by (212). I will check below that the superpotential preserves the anomaly-free R symmetry. Thus, this model has the same global symmetry (204) as the original supersymmetric QCD model. Seiberg refers to the relation between this theory and the original $SU(N_c)$ Yang-Mills theory as *non-Abelian electric-magnetic duality*. I will explain some aspects of the duality of these theories in a moment.

In this picture, the $SU(\tilde{N}_c)$ gauge group comes out of nowhere. Its initial role is to parametrize the constraint that the dual quark fields q, \bar{q} should combine correctly into the baryon fields. However, systems are known in which a gauge field which arises in this way to parametrize a constraint can become dynamical. The most famous example is the CP^N nonlinear sigma model in 2 dimensions.^{57,58} In any event, we will assume here that the $SU(\tilde{N}_c)$ gauge symmetry is realized with a fully dynamical Yang-Mills theory, including asymptotic gauge bosons and gauginos. With this idea, we place the theory in a Coulomb phase of the $SU(\tilde{N}_c)$ Yang-Mills theory in which the full complement of $SU(\tilde{N}_c)$ gauge bosons are massless. Now we would like to ask, can we find nontrivial consistency checks of this picture?

I have emphasize that the 't Hooft anomaly condition provides a stringent test of the low-energy particle content of a strongly-coupled gauge theory. Let us apply the test here, at the maximally symmetric point where none of the fields acquire vacuum expectation values and the full global symmetry (204) is realized. The original quark superfields have the quantum numbers

$$Q : (N_f, 1)_{1, 1-N_c/N_f} \quad \bar{Q} : (1, \bar{N}_f)_{-1, 1-N_c/N_f} , \quad (213)$$

using (49) for the R charge. Then the quantum numbers of the elementary fermions are

$$\psi_Q : (N_f, 1)_{1, -N_c/N_f} \quad \psi_{\bar{Q}} : (1, \bar{N}_f)_{1, -N_c/N_f} \quad \lambda : (1, 1)_{0, +1} . \quad (214)$$

To obtain the quantum numbers of the superfields in the dual description, compute the quantum numbers of a baryon field from (213) and then divide the result among its \tilde{N}_c components. This gives

$$q : (\bar{N}_f, 1)_{N_c/\tilde{N}_c, N_c/N_f} \quad \bar{q} : (1, N_f)_{-N_c/\tilde{N}_c, N_c/N_f} . \quad (215)$$

Then the fermionic components of these fields have the quantum numbers

$$\psi_q : (\bar{N}_f, 1)_{N_c/\tilde{N}_c, -1+N_c/N_f} \quad \psi_{\bar{q}} : (1, \bar{N}_f)_{-N_c/\tilde{N}_c, -1+N_c/N_f} . \quad (216)$$

In addition, the physical fermions of the dual picture include the superpartners of T and the $SU(\tilde{N}_c)$ gauginos,

$$\psi_T : (N_f, \bar{N}_f)_{0,1-2N_c/N_f} \quad \lambda : (1,1)_{0,+1} . \quad (217)$$

From this fermion content, it is straightforward to check the matching of all of the possible anomaly coefficients:

	<i>elementary</i>	<i>composite</i>	
$(SU(N_f))^3 :$	AN_c	AN_c	
$(SU_L(N_f))^2 U_B(1) :$	$\frac{1}{2}N_c$	$\frac{1}{2}N_c$	
$(SU_L(N_f))^2 U_R(1) :$	$-\frac{1}{2}N_c^2/N_f$	$-\frac{1}{2}N_c^2/N_f$	(218)
$(U_B(1))^2 U_R(1) :$	$-2N_c^2$	$-2N_c^2$	
$\text{tr}[U_R(1)] :$	$-(N_c^2 + 1)$	$-(N_c^2 + 1)$	
$(U_r(1))^3 :$	$N_c^2 - 1 - 2N_c^4/N_f^2$	$N_c^2 - 1 - 2N_c^4/N_f^2$	

In the last two of these relations, the dual gauginos give a contribution which is necessary for the success of the consistency check. Since the value of this contribution is $(\tilde{N}_c^2 - 1) \cdot (-1)$, including a sum over the dual gauge color quantum numbers, the matching requires us to take seriously the realization of the full $SU(\tilde{N}_c)$ gauge supermultiplet as a set of physical asymptotic states.

7.4 Decoupling relations

To make further checks of Seiberg's proposal, we should ask whether it connects correctly, through holomorphic decoupling, to the picture we have derived for supersymmetric QCD with a smaller number of flavors. In the process of answering this questions, we will find two other decoupling relations which also provide nontrivial checks of Seiberg's duality.

The first of these addresses the question of whether the duality relation is in fact a duality. If we act with the relation twice, do we recover the original theory? Start with a supersymmetric Yang-Mills theory of $SU(N_c)$ with N_f flavors and no superpotential. By the duality relation, this should be equivalent to a Yang-Mills theory with gauge group $SU(\tilde{N}_c)$, an extra chiral multiplet T which is a singlet of the gauge group, and the superpotential given in (212). Carrying out the duality transformation once again, we find a Yang-Mills theory with gauge group $SU(N_c)$, an extra chiral multiplet U which is a singlet of the gauge group, and a superpotential of the form (212) which couples U

to the quark fields of $SU(N_c)$. The superfield U is identified with the bilinear $\bar{q}^i q^j$. Thus, the final theory contains two singlet multiplets T and U and the superpotential

$$W = q T \bar{q} + Q U \bar{Q} = \text{tr} U T + Q U \bar{Q} . \quad (219)$$

The first term in this expression gives mass to all of the components of T and U . In addition, the F -flatness condition for F_T implies that $U = 0$. Thus, when T and U decouple, we are left with an $SU(N_c)$ gauge theory with zero superpotential, just the theory that we started with.

Next, consider the effect of adding a mass term for the last flavor. I will assume for the moment that $N_f > N_c + 2$, so that this decoupling should connect two theories which would both be expected to exhibit Seiberg's duality. In the original theory, decoupling the N_f th flavor gives a supersymmetric Yang-Mills theory with $(N_f - 1)$ flavors and zero superpotential.

In the dual theory, the addition of the mass term gives us the superpotential

$$W = q T \bar{q} + m T_{N_f N_f} . \quad (220)$$

The F -flatness conditions for the $T_{N_f N_f}$, q_{N_f} and \bar{q}_{N_f} are

$$q_{N_f}^a \bar{q}_{N_f}^a + m = 0 \quad (T \cdot \bar{q}^a)_{N_f} = (q^a \cdot T)_{N_f} = 0 . \quad (221)$$

In this equation, I have explicitly written the $SU(\tilde{N}_c)$ gauge indices a . To solve the first of these equations, $q_{N_f}^a$ and $\bar{q}_{N_f}^a$ must obtain vacuum expectation values along a parallel direction of the gauge group. These expectation values break $SU(N_c)$ to $SU(\tilde{N}_c - 1)$. Then the second and third equations in (221) imply that the N_f th row and column of T^{ij} vanish. The final result is an $SU(\tilde{N}_c - 1)$ gauge theory with $(N_f - 1)$ flavors, a gauge singlet superfield T which is an $(N_f - 1) \times (N_f - 1)$ matrix, and the superpotential (212) coupling T to the quark superfields. This is the Seiberg dual of supersymmetric Yang-Mills theory with $(N_f - 1)$ flavors.

We have now seen that holomorphic decoupling correctly connects different theories with Seiberg's duality in a way that preserves the duality relation. However, we still need to check that the theories with Seiberg's duality are correctly connected to the supersymmetric QCD models with a smaller number of flavors which we have described in earlier sections using different physical pictures. To check this connection, consider decoupling the last flavor in supersymmetric QCD with $(N_c + 2)$ flavors. In this case, the dual Yang-Mills theory has $SU(2)$ gauge symmetry. The analysis of the previous paragraph still applies to this case, leading to a superpotential of the form (212) with q_i , \bar{q}_i now 1-component fields for each value of $i = 1, \dots, (N_c + 1)$.

At the same time, the expectation values of q_{N_f} and \bar{q}_{N_f} break the $SU(2)$ gauge symmetry completely. Thus, as in Section 4.4, this case provides us with a well-defined instanton calculation which potentially adds another term to the superpotential. As in that section, we can analyze the instanton effect by counting zero modes. The instanton creates one each of the fermions ψ_{q_i} , $\psi_{\bar{q}_i}$, and 4 dual gauginos λ . We can turn four quarks into squark fields using the squark-quark-gaugino coupling and replace the squark fields with $i = N_f$ by the vacuum expectation values of these fields. We can then use the superpotential coupling to convert pairs $\psi_{q_i}\psi_{\bar{q}_j}$ to T^{ij} or pairs $q_i\psi_{\bar{q}_j}$ to ψ_T^{ij} . This allows us to construct an effective interaction with two fermions which contains $(N_f - 1)$ powers of T^{ij} or ψ_T^{ij} , $i, j = 1, \dots, (N_f - 1)$, in a combination invariant to the residual $SU(N_f - 1) \times SU(N_f - 1)$ flavor symmetry. This interaction has the form of a superpotential correction

$$\int d^2\theta \Delta W = \int d^2\theta \det T, \quad (222)$$

up to an overall constant depending on Λ and $\langle q_{N_f} \rangle$. Putting together the two contributions to the superpotential, we find

$$W_{\text{eff}} = (q \cdot T \cdot \bar{q} - \det T). \quad (223)$$

This has exactly the form of the superpotential (198) which we wrote for the theory with $(N_c + 1)$ flavors, with the identification

$$q_i \rightarrow B_i \quad \bar{q}_i \rightarrow \bar{B}_i. \quad (224)$$

Now the whole chain of effective descriptions of supersymmetric QCD, from $N_f = 0$ to large values of N_f , is linked together by holomorphic decoupling.

7.5 Fixed points and asymptotic states

In the analysis we have just completed, it seemed that Seiberg's duality could connect supersymmetric Yang-Mills theories with arbitrarily large values of N_f . But there is a problem here, because, for sufficiently large N_f , the Yang-Mills theory will lose asymptotic freedom. In this case, the theory reverts to a weakly-coupled system of quark and gluon supermultiplets, interacting through asymptotically decaying forces. There does not seem to be a role here for the dual quark and gaugino fields which I insisted in the previous section should be thought of as physical particles.

To understand how the regime with non-Abelian duality fits together with this infrared-free regime, Seiberg proposed an additional interesting hypothesis:

At fixed N_c , for some intermediate region of N_f , supersymmetric QCD is described by a scale-invariant theory which would be a new infrared fixed point of the renormalization group. In fact, this fixed point is already known in a certain region of N_f . In nonsupersymmetric gauge theories, at the point in N_f where the first β function coefficient vanishes, the second β function coefficient has already turned positive. Thus, for values of N_f just below the critical value N_f^c where asymptotic freedom is lost, there is an infrared fixed point at a weak coupling $g^2/4\pi \sim (N_f^c - N_f)$.⁵⁹ A similar result holds in the supersymmetric case. Seiberg conjectured that this fixed point extends downward in N_f through a significant region.

In a supersymmetric field theory, a scale-invariant point necessarily has *superconformal* invariance, and this extension of the global symmetry group adds interesting structure to the theory. Recall that, in supersymmetric theories, the energy-momentum tensor $T^{\mu\nu}$ belongs to a supermultiplet which also contains the supersymmetry current S_α^μ and a $U(1)$ current J^μ . In a classical scale-invariant supersymmetric theory, J^μ is the current of the canonical R symmetry. Ordinary supersymmetry implies that $T^{\mu\nu}$ and S_α^μ are conserved. Superconformal invariance implies, in addition,

$$T_\mu^\mu = 0 \quad \gamma_{\alpha\beta}^\mu S_{\mu\beta} = 0 \quad \partial_\mu J^\mu = 0 . \quad (225)$$

At a fixed point of supersymmetric QCD, then, J^μ must be the conserved current of the anomaly-free R symmetry. The superconformal algebra gives restrictions on the eigenvalues of these operators. In particular, the scaling dimension of a field is bounded by its R charge,

$$d \geq \frac{3}{2}|R| ; \quad (226)$$

the inequality is saturated for chiral and antichiral superfields.⁶⁰ In addition, as is true in the nonsupersymmetric case, the scaling dimension of a scalar field must satisfy

$$d \geq 1 , \quad (227)$$

with $d = 1$ possible only for a free field.⁶¹ I should note that both of these inequalities apply strictly only to gauge-invariant operators.

Consider the implications of these statements if supersymmetric QCD is scale-invariant in a region where it exhibits Seiberg's duality. Since the basic objects of our description are chiral superfields, we can work out their scaling dimensions from their R charges. In particular, for the gauge-invariant combinations,

$$Q \cdot \bar{Q} = T \quad \text{has} \quad d = 3 \left(\frac{N_f - N_c}{N_f} \right)$$

$$q \cdot \bar{q} = U \quad \text{has} \quad d = 3 \left(\frac{N_c}{N_f} \right) \quad (228)$$

As a check on these relations, the superpotential (212) has $R = 2$, as needed to preserve the R symmetry. By (226), this superpotential would also have $d = 3$, which is the correct value for this to be a marginal perturbation.

In supersymmetric QCD, the β function coefficient b_0 is given by (38) and vanishes at $N_f = 3N_c$. At this point, the bilinear U in (228) comes down to $d = 1$ and becomes a free field. For larger values of N_f , the dual theory can no longer be consistently described as a superconformal fixed point, but this is just as well, because the original QCD is known not to be scale-invariant in this regime. Rather, it is a theory with weak gauge interactions whose strength decreases logarithmically at large distances.

In a similar way, the dimension of the bilinear T reaches 1 at $N_f = 3N_c/2$. This value has another significance; since the beta function coefficient of the dual theory is

$$b_0 = 3\tilde{N}_c - N_f = 2N_f - 3N_c, \quad (229)$$

this is the value of N_f below which the dual theory becomes infrared-free.

From this information, we can put together the following picture of the behavior of supersymmetric QCD for values of N_f greater than N_c . For $N_f = (N_c + 1)$, the asymptotic particles are the mesons T and baryons B and \bar{B} and their superpartners. For the next few values of N_f , the asymptotic particles are the mesons T and the dual quarks q and \bar{q} , interacting through an infrared-free supersymmetric Yang-Mills theory of $SU(\tilde{N}_c)$. Above $N_f = 3N_c/2$, however, the theory goes to a nontrivial infrared fixed point which is an attractor for both the original and the dual Lagrangian. As N_f increases, this fixed point theory looks less and less like the dual Yang-Mills theory and more and more like a weakly-coupled version of the original Yang-Mills theory. Finally, at $N_f = 3N_c$, the fixed point comes to zero coupling in the original supersymmetric Yang-Mills theory. For still higher values of N_f , the asymptotic particles are the original quarks, interacting through an infrared-free supersymmetric Yang-Mills theory of $SU(N_c)$. The whole picture of the evolution of supersymmetric Yang-Mills theory with N_f is displayed in Figure 12.

An interesting aspect of the plan shown in this figure is that, as N_f decreases, the qualitative behavior of the theory contains increasingly more strong-coupling, nonperturbative dynamics for the original quarks and gluons. We proceed from a free region, to a fixed-point region, to a region of confinement, to the extreme region of the Affleck-Dine-Seiberg superpotential. On the other hand, along this same axis, the dual theory changes from a strongly-coupled, confining theory to a free theory. Where one coupling is weak, the

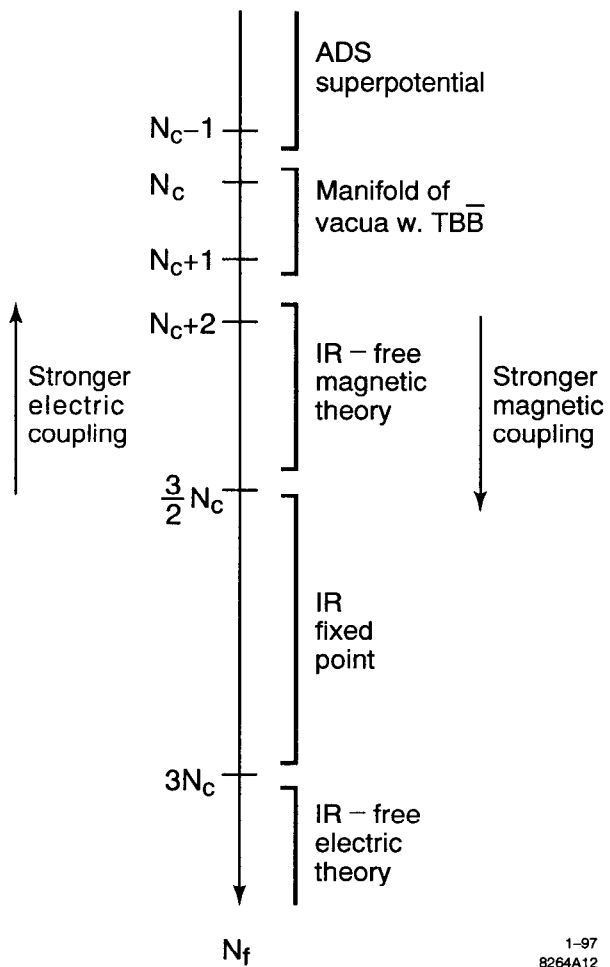

1-97
8264A12

Figure 12: Seiberg's plan of the behaviour of supersymmetric Yang-Mills theory as a function of the number of flavors N_f .

dual coupling is strong. This behavior strongly motivates Seiberg's idea that the relation of the original and dual pictures is a non-Abelian generalization of electric-magnetic duality.

Although our analysis in this section has been given for supersymmetric QCD, it is highly suggestive that a similar behavior could appear in ordinary nonsupersymmetric QCD. For a sufficiently small number of flavors, we have color confinement and chiral symmetry breaking due to the expectation value of the quark bilinear (3). However, for larger values of N_f , the theory could go to an infrared fixed point which corresponds to an asymptotic non-Abelian Coulomb phase with no chiral symmetry breaking. Some time ago, Banks and Zaks argued that such a phase always appears for N_f sufficiently close to the critical value at which the theory loses asymptotic freedom.⁵⁹ And there is some evidence from numerical lattice simulations that QCD with the gauge group $SU(3)$ no longer exhibits confinement and chiral symmetry breaking for $N_f > 7$.⁶² It will be very interesting to learn whether the complete picture that Seiberg has assembled for supersymmetric QCD has a direct analogue in nonsupersymmetric QCD.

To conclude this section, I would like to note two interesting checks of Seiberg's duality. Argyres, Plesser, and Seiberg⁶³ have studied the duality starting from $N = 2$ supersymmetric QCD, by introducing explicit breaking to $N = 1$. They have exhibited a point in the Coulomb phase of the $N = 2$ theory such that the reduction to $N = 1$ gives the Seiberg dual theory, and they have shown that this point can be continuously connected to the standard picture of supersymmetric QCD at weak coupling through a path in the $N = 2$ Coulomb phase. Bershadsky, Johansen, Pantev, Sadov, and Vafa⁶⁴ have recently identified Seiberg's duality in a stringy context, as a T -duality of certain Type IIB compactifications.

8 Generalizations of non-Abelian Duality

Seiberg's work described in the previous section gives a unified picture of the behavior of $N = 1$ supersymmetric $SU(N_c)$ Yang-Mills theories with N_f flavors for the whole range of possible values of N_f . We might draw from this analysis the insight that it is interesting to consider the systematics of other families of supersymmetric Yang-Mills theories with varying numbers of flavors. In this section, I will briefly discuss a few interesting cases. In the past year, many examples of strong-coupling behavior in $N = 1$ supersymmetric Yang-Mills theories have been explored. There is no space here for a complete review of this subject, but I hope that these examples will give an idea of the richness of the phenomena that have been uncovered.

8.1 $SO(N_c)$ and $Sp(2n_c)$

The simplest generalizations of Seiberg's duality occur in vectorlike $SO(N_c)$ and $Sp(2n_c)$ gauge theories with N_f flavors of quarks and squarks in the fundamental representation. I will now explain how the systematics of $SU(N_c)$ gauge theories presented in Section 7 extends to these theories.

Consider first $SO(N_c)$ gauge theories with N_f flavors of quarks and squarks Q^i in the representation of dimension N_f . The global flavor symmetry of this theory is $SU(N_f) \times U_R(1)$. The β function of the theory is given by

$$b_0 = 3(N_c - 2) - N_f . \quad (230)$$

The fundamental and adjoint representations of $SO(N_c)$ have anomaly coefficients n , as in (37), equal to 2 and $2(N_c - 2)$, respectively. Thus, for this theory we can make a table similar to (50). Let A represent the anomalous $U(1)$ flavor symmetry of the Q^i . Let R and R_{AF} represent the canonical and non-anomalous R symmetries; R_{AF} is given by

$$R_{AF} = R + \frac{N_f - N_c + 2}{N_f} A . \quad (231)$$

Let T^{ij} be the gauge-invariant chiral superfield $Q^i \cdot Q^j$; this is a symmetric tensor of the flavor $SU(N_f)$. Then we have

	A	R	R_{AF}	
Q^i	+1	0	$(N_f + 2 - N_c)/N_f$	
λ	0	+1	+1	(232)
Λ^{b_0}	$2N_f$	$-2(N_f + 2 - N_c)$	0	
$\det T$	$2N_f$	0	$2(N_f + 2 - N_c)$	

A nonperturbative superpotential for this theory must be invariant under A and must have R charge 2. From the data in the table, the only possibility is

$$W_{\text{eff}} = c \cdot \left(\frac{\Lambda^{b_0}}{\det T} \right)^{1/(N_c - 2 - N_f)} . \quad (233)$$

Thus, we expect that, for $N_f < (N_c - 2)$, a superpotential is generated in the matter described by Affleck, Dine, and Seiberg, while for $N_f \geq N_c$, there is an electric-magnetic duality.

The duality of the theory for large N_f has been worked out by Intriligator and Seiberg.⁶⁵ The dual theory is an $SO(N_f - N_c + 4)$ gauge theory with dual

quark superfields q_i in the $\overline{N_f}$ representation of the $SU(N_f)$ flavor group, the gauge singlet superfield T^{ij} , and the superpotential

$$W = T^{ij} q_i \cdot q_j . \quad (234)$$

This theory satisfies the 't Hooft anomaly conditions at the origin of moduli space in a manner similar to that of the $SU(N_c)$ duality.

For intermediate values of N_f , there are some interesting special cases.⁶⁵ For $N_f = N_c - 4$, the theory is described at weak coupling by expectation values $\langle Q^i \rangle$ which generically break $SO(N_c)$ to an $SO(4)$ pure gauge theory. Since $SO(4) = SU(2) \times SU(2)$, this theory has two $SU(2)$ gaugino condensates which are equal in magnitude. For each of these condensates, the Z_2 symmetry of the theory gives two choices (± 1) for its phase. If the two condensates are chosen parallel, we obtain the superpotential (233). If the two condensates are chosen antiparallel, we obtain a second branch of the theory with zero superpotential and a nontrivial moduli space. This second branch is also found in the case $N_f = N_c - 3$, reflecting the possibility of a cancellation between the contributions to the superpotential from the $SO(3)$ gaugino condensate and from explicit instanton effects. In this latter case, a new chiral field q_i in the $\overline{N_f}$ representation of $SU(N_f)$ is needed to satisfy the 't Hooft anomaly condition. For $N_f = N_c - 2$, no superpotential can be generated. The weak-coupling description of the theory has $SO(N_c)$ broken to $SO(2) = U(1)$, so the theory has a Coulomb phase. The new fields q_i from the previous case are generated by decoupling from magnetic monopoles in this theory. For $N_f = N_c - 1$, the theory is described by a dual $SO(3)$ gauge theory with the superpotential

$$W = T^{ij} q_i \cdot q_j - \det T . \quad (235)$$

Beginning with $N_f = N_c$, we find the generic situation for large N_f described in the previous paragraph. There are additional complications for the special cases of $N_c = 3, 4$.

For $Sp(2n_c)$ gauge theories, the situation is rather more straightforward.⁶⁶ For these theories, the number of flavors must be even to avoid discrete gauge anomalies. Thus, we introduce an even number $N_f = 2n_f$ of supermultiplets Q^i in the fundamental $2n_c$ -dimensional representation. The global flavor symmetry of this theory is $SU(2n_f) \times U_R(1)$. The β function of the theory is given by

$$b_0 = 3(2n_c + 2) - 2n_f . \quad (236)$$

The fundamental and adjoint representations of have anomaly coefficients n equal to 2 and $4(n_c + 1)$, respectively. Let A again represent the anomalous

$U(1)$ flavor symmetry of the Q^i . Let R and R_{AF} represent the canonical and non-anomalous R symmetries; R_{AF} is given by

$$R_{AF} = R + \frac{n_f - n_c - 1}{n_f} A. \quad (237)$$

Let T^{ij} be the gauge-invariant chiral superfield $Q^i \cdot Q^j$; this is an antisymmetric tensor of the flavor $SU(2n_f)$. Then the table of quantum numbers reads

	A	R	R_{AF}	
Q^i	+1	0	$(n_f - 1 - n_c)/n_f$	
λ	0	+1	+1	(238)
Λ^{b_0}	$4n_f$	$-4(n_f - 1 - n_c)$	0	
$\det T$	$4n_f$	0	$4(n_f - 1 - n_c)$	

Since T is an antisymmetric matrix, its determinant factorizes as the square of simpler object, the Pfaffian $\text{Pf } T$.

A nonperturbative superpotential for this theory must be invariant under A and must have R charge 2. The unique possibility is

$$W_{\text{eff}} = c \cdot \left(\frac{\Lambda^{b_0/2}}{\text{Pf } T} \right)^{1/(n_c+1-n_f)}. \quad (239)$$

This superpotential is generated for all cases $n_f < n_c + 1$. In the case $n_f = (n_c + 1)$, the theory has a moduli space of vacua with a nonperturbatively modified constraint

$$\text{Pf } T = \Lambda^{2(n_c+1)}. \quad (240)$$

For $n_f = (n_c + 2)$, the theory has a moduli space of vacua with the superpotential

$$W = \text{Pf } T. \quad (241)$$

For $n_f \geq (n_c + 3)$, the theory is dual to an $Sp(2(n_f - n_c - 2))$ gauge theory with quark superfields q_i in the $\overline{2n_f}$ representation of $SU(2n_f)$ and the superpotential

$$W = T^{ij} q_i \cdot q_j. \quad (242)$$

Thus, the vectorlike supersymmetric Yang-Mills theories based on the classical groups $SU(N_c)$, $SO(N_c)$, and $Sp(2n_c)$ all show similar patterns in their qualitative behavior.

8.2 Examples with chiral matter content

The systematics of $N = 1$ supersymmetric Yang-Mills theories becomes stranger when we consider models with more general representations. An interesting example to consider next is the $SU(N_c)$ model with a symmetric tensor multiplet S and N_f multiplets Q^i in the \overline{N}_c representation. This is a chiral gauge theory, and the cancellation of gauge anomalies requires $N_f = N_c + 4$. This theory has a large number of possible gauge-invariant chiral fields, of which the two simplest are

$$U = \det S, \quad M^{ij} = Q^i \cdot S \cdot Q^j, \quad (243)$$

a singlet and a symmetric tensor of the flavor group $SU(N_f)$.

Pouliot and Strassler have found that the properties of this theory are matched by a dual gauge theory with the gauge group $SO(8)$.⁶⁷ The dual theory contains N_f multiplets q_i in vector representations, one multiplet p in the spinor representation, and gauge singlet fields U and M^{ij} . The dual theory has a nontrivial superpotential

$$W = M^{ij} q_i \cdot q_j + U p \cdot p. \quad (244)$$

Reciprocally, the $SO(8)$ theory with the same charged matter content q_i , p and zero superpotential is dual to an $SU(N_c)$ gauge theory with a symmetric tensor multiplet S , quarks Q^i , and the additional gauge singlet fields

$$T = p \cdot p, \quad N^{ij} = q_i \cdot q_j \quad (245)$$

and the superpotential

$$W = N_{ij} Q^i \cdot S \cdot Q^j + T \det S. \quad (246)$$

This is a bizarre transformation. In the forward direction, we began from a chiral gauge theory, but the dual was a vectorlike theory. In the reciprocal relation, we began from a vectorlike theory and found a chiral theory as the dual. This turns out to be a common phenomenon in the more complex examples of non-Abelian duality. The first example was found by Pouliot in an $SO(7)$ model.⁶⁸

Similar examples can be found in models with antisymmetric tensor representations. Consider, for example, $SU(N_c)$ Yang-Mills theory with an antisymmetric tensor representation A^{ij} , M multiplets Q^i in the N_c representation, and N multiplets \overline{Q}_i in the \overline{N}_c representation, and zero superpotential. Anomaly cancellation requires $N = N_c - 4 + M$. As M is increased, this theory exhibits a progression of behaviors, with a nonperturbative superpotential

generated for $M \leq 2$, a constrained moduli space with a nonperturbative correction for $M = 3$, and a moduli space of vacua with a superpotential for $M = 4$.⁶⁹ Pouliot has shown that, for $M \geq 5$, this theory has as a dual which is an $SU(M-3) \times Sp(2(M-4))$ gauge theory. The matter content is rather large. Let me denote the fundamental representation by f and the antisymmetric tensor representation by a , and write for each multiplet the content under the gauge group and the non-Abelian part of the flavor group. Then each multiplet belongs to a representation of $SU(M-3) \times Sp(2(M-4)) \times SU(M) \times SU(N)$. In this notation, the dual theory contains the multiplets

$$\begin{aligned}
x &: (f, f; 1, 1), & p &: (f, 1; 1, 1), \\
\bar{a} &: (\bar{a}, 1; 1, 1), & \bar{q} &: (\bar{f}, 1; \bar{f}, 1), \\
\ell &: (1, f; 1, \bar{f}), & M &: (1, 1; f, f), \\
H &: (1, 1; 1, a), & B &: (1, 1; f, 1)
\end{aligned} \tag{247}$$

interacting through the superpotential

$$W = M\bar{q}\ell x + H\ell\ell + Bp\bar{q} + \bar{a}x^2. \tag{248}$$

This theory brings us into territory that is interesting for another reason. $SU(N_c)$ gauge theories with antisymmetric tensor representations provide the simplest examples of supersymmetric Yang-Mills theories with spontaneously broken supersymmetry. Some time ago, Affleck, Dine, and Seiberg pointed out that the $SU(5)$ gauge theory with one 10 and one $\bar{5}$ matter superfield spontaneously breaks supersymmetry.⁷¹ The intuitive reason for this is easy to understand from the considerations of Section 4: The origin of field space where the 10 and $\bar{5}$ have zero vacuum expectation values is destabilized by nonperturbative dynamics, as we found there. But, since it is not possible to build a gauge-invariant chiral field from these ingredients, there are no D -flat directions along which the vacuum can escape to infinity. Recently, Murayama⁷² has made this argument quite concrete by studying the $SU(5)$ gauge theory with a 10, two $\bar{5}$ s, and a 5 with a mass term that decouples one $5 + \bar{5}$ pair. The argument can be repeated for every larger odd value of N_c . In those theories, there is a D -flat direction along which the theory can escape to infinity, but at the end of this trajectory the theory is broken only to $SU(5)$. Thus, there is no possible vacuum state that preserves supersymmetry.

The example just discussed shows the possibility of exploring dynamical supersymmetry breaking using duality. Indeed, Pouliot showed that, when one decouples M flavors in the dual picture, the resulting theory has a superpotential which does not allow an F -flat vacuum configuration.⁷⁰

By combining the various ingredients that I have discussed in these lectures, working with non-simple gauge groups and including explicit as well as dynamical superpotentials, it is possible to construct a wide variety of models of dynamical supersymmetry breaking. Intriligator and Thomas have presented a catalogue of supersymmetry-breaking mechanisms that appear in these models,⁷³ and many examples are now being generated.

On the other hand, the broad picture of non-Abelian duality in $N = 1$ supersymmetric Yang-Mills theory remains far from clear. Many examples of duality have been generated in the past year, many more than I have space to review, but as yet there is no broad picture of the systematics of this phenomenon. The recent papers^{74,75} are two recent attempts to bring order to the $N = 1$ gauge theories, neither completely successful. Most likely, there are many strange things still to be learned about these models.

In this atmosphere of promise and confusion, I end these lectures. I wish you, the reader, good luck in finding the connections among supersymmetric Yang-Mills theories that are still hidden. I hope that we will also be able to find a place for the wealth of phenomenon these theories provide in realistic models of Nature.

Acknowledgments

I am grateful to Brian Greene and K. T. Mahantappa for the opportunity to participate in this stimulating school, and to Alex C.-L. Chou, Michael Dine, Joseph Minahan, Ann Nelson, Nati Seiberg, Michael Shifman, Scott Thomas, Shimon Yankielowicz, and many other people who have helped me to understand the topics reviewed here. This work was supported by the Department of Energy under contract DE-AC03-76SF00515.

References

1. I. Affleck, M. Dine, and N. Seiberg, *Phys. Rev. Lett.* **51**, 1026 (1983), *Nucl. Phys. B* **241**, 493 (1984).
2. N. Seiberg and E. Witten, *Nucl. Phys. B* **426**, 19 (1994), E **430**, 485 (1994).
3. N. Seiberg and E. Witten, *Nucl. Phys. B* **431**, 484 (1994).
4. N. Seiberg, *Nucl. Phys. B* **435**, 129 (1995).
5. K. Wilson, *Phys. Rev. D* **10**, 2445 (1974).
6. T. DeGrand, hep-th/9610132, in these proceedings.
7. M. E. Peskin, in *Recent Advances in Field Theory and Statistical Mechanics*, J.-B. Zuber and R. Stora, eds. (North-Holland, Amsterdam,

- 1984).
8. H. Georgi, *Weak Interactions and Modern Particle Theory*. (Benjamin/Cummings, Reading, 1984).
 9. J. Gasser and H. Leutwyler, *Ann. Phys.* **158**, 142 (1984), *Nucl. Phys. B* **250**, 465 (1985).
 10. J. F. Donoghue, E. Golowich, and B. Holstein, *Dynamics of the Standard Model*. (Cambridge University Press, Cambridge, 1992).
 11. H. B. Nielsen and P. Olesen, *Nucl. Phys. B* **61**, 45 (1973).
 12. L. J. Tassie, *Phys. Lett. B* **46**, 397 (1973).
 13. M. E. Peskin, *Ann. Phys.* **113**, 122 (1978).
 14. D. Horn, M. Weinstein, and S. Yankielowicz, *Phys. Rev. D* **19**, 3715 (1979).
 15. A. Ukawa, P. Windey, and A. H. Guth, *Phys. Rev. D* **21**, 1013 (1980).
 16. E. Fradkin and S. H. Shenker, *Phys. Rev. D* **19**, 3682 (1979).
 17. S. Dimopoulos, S. Raby, and L. Susskind, *Nucl. Phys. B* **173**, 208 (1980).
 18. J. Lykken, hep-th/9612114, in these proceedings.
 19. J. Iliopoulos and B. Zumino, *Nucl. Phys. B* **76**, 310 (1974).
 20. M. Grisaru, W. Siegel, and M. Roček, *Nucl. Phys. B* **159**, 429 (1979).
 21. M. A. Shifman and A. I. Vainshtein, *Nucl. Phys. B* **277**, 456 (1986), *Nucl. Phys. B* **359**, 571 (1991).
 22. M. Dine and Y. Shirman, *Phys. Rev. D* **50**, 5389 (1994).
 23. L. O'Raifeartaigh, *Nucl. Phys. B* **96**, 331 (1975).
 24. M. A. Luty and W. Taylor, *Phys. Rev. D* **53**, 3399 (1996).
 25. G. Veneziano and S. Yankielowicz, *Phys. Lett. B* **113**, 231 (1982).
 26. T. R. Taylor, G. Veneziano, and S. Yankielowicz, *Nucl. Phys. B* **218**, 493 (1983).
 27. D. Finnell and P. Pouliot, *Nucl. Phys. B* **453**, 225 (1995).
 28. S. Coleman, *Aspects of Symmetry*. (Cambridge University Press, Cambridge, 1985).
 29. S. Cordes, *Nucl. Phys. B* **273**, 629 (1986).
 30. M. A. Shifman and A. I. Vainshtein, *Nucl. Phys. B* **296**, 445 (1988).
 31. O. Aharony, J. Sonnenschein, S. Yankielowicz, M. E. Peskin, and S. Yankielowicz, *Phys. Rev. D* **52**, 6157 (1995).
 32. N. Seiberg, *Phys. Rev. D* **49**, 6857 (1994).
 33. G. 't Hooft, *Nucl. Phys. B* **79**, 276 (1974).
 34. A. M. Polyakov, *JETP Lett.* **20**, 194 (1974).
 35. E. B. Bogomolny, *Sov. J. Nucl. Phys.* **24**, 449 (1976).
 36. M. K. Prasad and C. Sommerfield, *Phys. Rev. Lett.* **35**, 760 (1975).
 37. J. Harvey, hep-th/9603086, in these proceedings.
 38. E. Witten, *Phys. Lett. B* **86**, 283 (1979).

39. N. Dorey, M. Mattis, and V. V. Khoze, *Phys. Rev. D* **54**, 2921, 7832 (1996).
40. H. Aoyama, T. Harano, M. Sato, and S. Wada, *Phys. Lett. B* **388**, 331 (1996).
41. P. C. Argyres and M. R. Douglas, *Nucl. Phys. B* **448**, 93 (1995).
42. P. C. Argyres, M. R. Plesser, N. Seiberg, and E. Witten, *Nucl. Phys. B* **461**, 71 (1996).
43. P. Argyres and A. Faraggi, *Phys. Rev. Lett.* **73**, 3931 (1995).
44. A. Klemm, W. Lerche, S. Theisen, and S. Yankielowicz, *Phys. Lett. B* **344**, 169 (1995).
45. A. Hanany and Y. Oz, *Nucl. Phys. B* **452**, 283 (1995).
46. P. C. Argyres, M. R. Plesser, and A. D. Shapere, *Phys. Rev. Lett.* **75**, 1699 (1995).
47. D. Nemeschansky and J. Minahan, *Nucl. Phys. B* **464**, 3 (1996).
48. S. Kachru and C. Vafa, *Nucl. Phys. B* **450**, 69 (1995).
49. S. Kachru, A. Klemm, W. Lerche, P. Mayr, and C. Vafa, *Nucl. Phys. B* **459**, 537 (1996).
50. A. Klemm, W. Lerche, P. Mayr, C. Vafa, and N. Warner, *Nucl. Phys. B* **477**, 746 (1996).
51. W. Lerche, hep-th/9611190, to appear in the proceedings of the 1996 Trieste Spring School.
52. A. Sen, *Nucl. Phys. B* **475**, 562 (1996).
53. T. Banks, M. R. Douglas, and N. Seiberg, *Phys. Lett. B* **387**, 278 (1996).
54. G. 't Hooft, in *Recent Developments in Gauge Theories*, G. 't Hooft, C. Itzykson, A. Jaffe, H. Lehmann, P. K. Mitter, I. M. Singer, and R. Stora, eds. (Plenum Press, New York, 1980).
55. Y. Frishman, A. Schwimmer, T. Banks, and S. Yankielowicz, *Nucl. Phys. B* **177**, 157 (1981).
56. L. Alvarez-Gaumé and E. Witten, *Nucl. Phys. B* **234**, 269 (1985).
57. A. D'Adda, M. Lüscher, and P. Di Vecchia, *Nucl. Phys. B* **146**, 63 (1978), **152**, 125 (1979).
58. E. Witten, *Nucl. Phys. B* **149**, 285 (1979).
59. T. Banks and A. Zaks, *Nucl. Phys. B* **196**, 189 (1982).
60. M. F. Sohnius, in *Supersymmetry and Supergravity 1983*, B. Milewski, ed. (World Scientific, Singapore, 1983).
61. G. Mack, *Comm. Math. Phys.* **55**, 1 (1977).
62. Y. Iwasaki, K. Kanaya, S. Sakai, and T. Yoshié, *Phys. Rev. Lett.* **69**, 21 (1992).
63. P. C. Argyres, M. R. Plesser, and N. Seiberg, *Nucl. Phys. B* **471**, 159 (1996).

64. M. Bershadsky, A. Johansen, T. Pantev, V. Sadov, and C. Vafa, hep-th/9612052.
65. K. Intriligator and N. Seiberg, *Nucl. Phys. B* **444**, 125 (1995).
66. K. Intriligator and P. Pouliot, *Phys. Lett. B* **353**, 471 (1995).
67. P. Pouliot and M. J. Strassler, *Phys. Lett. B* **370**, 76 (1996).
68. P. Pouliot, *Phys. Lett. B* **359**, 108 (1995).
69. E. Poppitz and S. P. Trivedi, *Phys. Lett. B* **365**, 125 (1996).
70. P. Pouliot, *Phys. Lett. B* **367**, 151 (1996).
71. I. Affleck, M. Dine, and N. Seiberg, *Phys. Lett. B* **137**, 187 (1984).
72. H. Murayama, *Phys. Lett. B* **355**, 187 (1995).
73. K. Intriligator and S. Thomas, *Nucl. Phys. B* **473**, 121 (1996), hep-th/9608046.
74. J. H. Brodie and M. J. Strassler, hep-th/9611197.
75. C. Csaki, M. Schmaltz, and W. Skiba, hep-th/9612207.