

## Control of Coaxial Cable Propagation Delay for a Beam Phase Monitor

D. McCormick and M. Ross \*

Stanford Linear Accelerator Center  
Stanford University, Stanford, CA 94309

### ABSTRACT\*

The average position of the beam near the crest of the accelerating voltage in the Stanford Linear Collider linac must be kept stable to a fraction of an S-band wavelength or about 0.5ps. Temperature stabilized S-band RF distribution cables and phase monitors have been installed along the 3km linac to minimize the effects of the up to 40 degree F daily temperature excursions in the support building environment. In this paper, we present test results of the equipment designed to determine the stability of the RF distribution system by comparing it directly to the beam. In particular, efforts to stabilize the propagation delay of the system's coaxial cables will be described.

### INTRODUCTION

Improvements to the SLC RF distribution system have produced a marked reduction in the magnitude of the corrections applied to the RF phase and timing. However, small corrections still must be applied by the operators to maintain proper beam conditions at the end of the linac. A time domain beam phase monitor that measures the phase of the RF with respect to the beam has been developed to determine the cause of these residual phase and timing drifts. The design, performance and limitations of this system will be discussed in this paper.

The propagation delay of coaxial cables used in a beam phase monitor must be tightly controlled. Temperature fluctuations in the klystron support building can produce several picoseconds of delay change in a 5m coaxial cable. A successful beam phase monitor must use temperature stabilized coaxial cables. For SLC, the temperature stabilization of low level RF cables has been accomplished by placing the cables inside double wall tubing with temperature controlled water flowing between the walls. This system is heavy, rigid and quite labor intensive to install. A new system has been developed that eliminates these problems and maintains the same level of temperature stabilization.

### BEAM PHASE MONITOR

A beam phase monitor has been developed using a Hewlett Packard 54120 digital sampling oscilloscope. Scope control and data acquisition are performed by a Macintosh computer running National Instruments' LabView software. A block diagram of the system components is shown in figure 1. The scope is triggered by the signal from a BPM (beam position monitor), while a 2856MHz signal from the RF distribution system is expanded around a zero crossing and digitized. Assuming that the arrival time of the relativistic beam is invariant, variations in the readings are due to propagation delay changes in the RF distribution system.

\*Work supported by Department of Energy contract DE-AC03-76SF00515

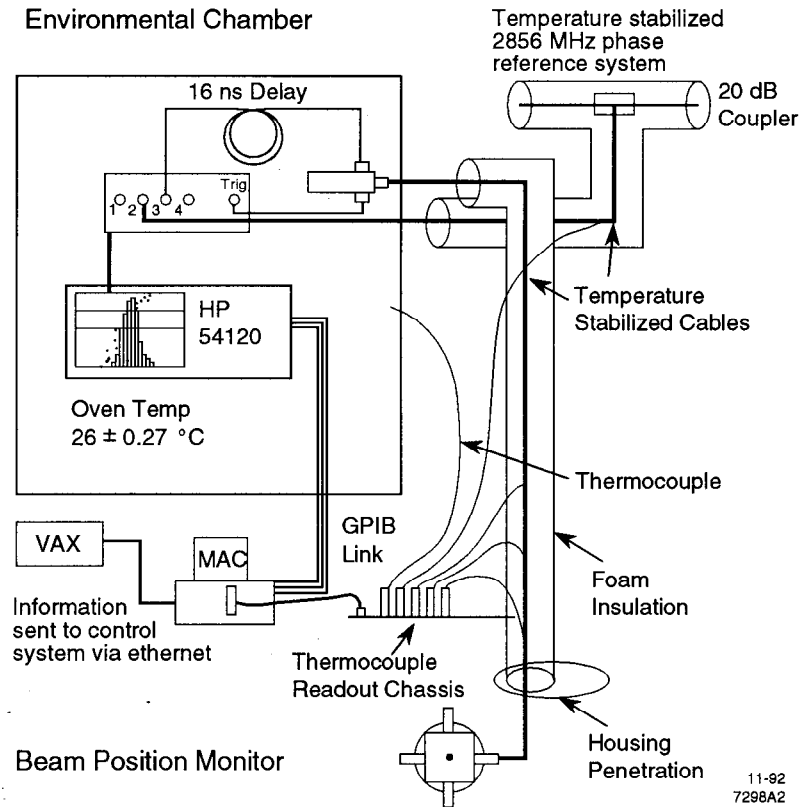
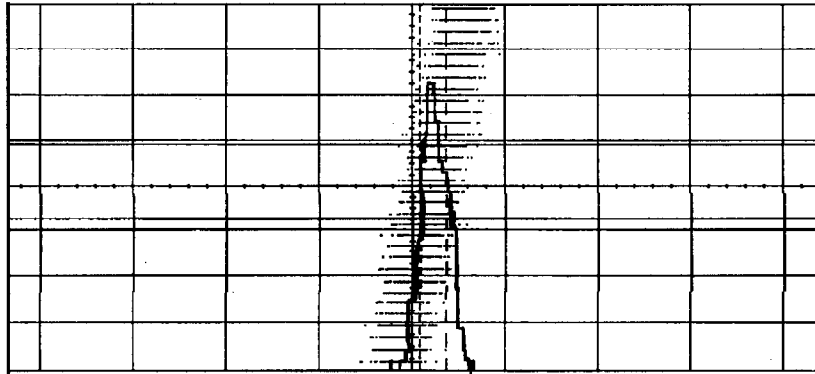

Fig. 1: Block diagram of a beam phase monitor system showing the temperature controlled oscilloscope and coaxial cables. Oscilloscope control and data acquisition are controlled by a Macintosh computer running LabView software.

## PERFORMANCE

This scope has a sampling resolution of 0.25ps and a trigger jitter of 3.3ps when operated with minimum internal delay. In order to meet the resolution goal of 0.5 degree S-band (1.0 degree S-band is approximately one picosecond), measurements must be made over many machine pulses. Data is acquired using the scope's histogram mode. This is an internal scope routine used to provide the averaging needed to obtain the desired resolution. In this mode, two voltage cursors are placed on the screen around the part of the waveform to be digitized. This portion of the waveform is sampled until the specified number of points are acquired. The resultant data is displayed on the scope in a histogram (figure 2). Data from the histogram measurement is transferred to the Macintosh computer over a GPIB link. The mean and the sigma of the histogram are then calculated. Variations of the mean are a measure of the phase shift between the beam and the RF while the sigma provides an indication of the quality of the data. The mean and the sigma are written to data files and can be transferred to the SLC control system computer for later analysis. Figure 3 shows beam phase measurements made at the start of the linac vs. time.



Ch1 = 1 mV/div  
timebase = 10ps/div

Mean = 78.9873ns  
Sigma = 1.4ps

Fig. 2: Histogram of expanded 2856MHz waveform sampled between cursors. The mean of the histogram provides a time domain beam phase measurement while the sigma indicates the quality of the data.

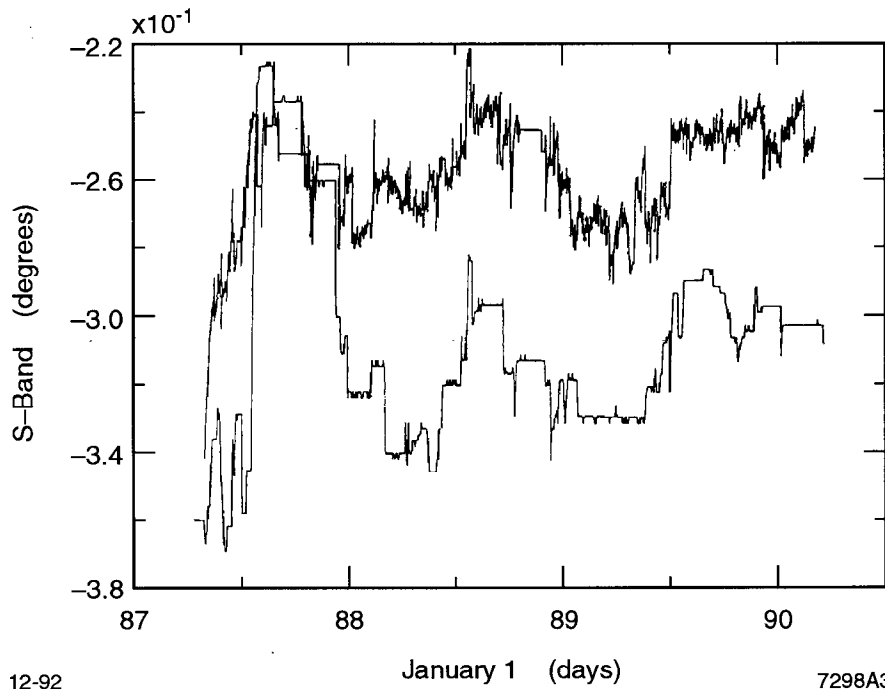

Fig. 3: Data from a beam phase monitor at the start of the linac(top trace). Phase adjustments made by operators at the start of the linac(bottom trace). Beam stability was poor from the start of the data to mid-morning of day 88. This produced the poor correlation between the operator phase adjustments and the beam phase monitor data seen for this period.

## SOURCES OF PHASE MEASUREMENT ERROR

### OSCILLOSCOPE TRIGGERING

Making measurements on the subpicosecond level requires stable triggering of the oscilloscope. Variations in the beam current produce changes in the slope of the BPM signal used for the trigger. This introduces a shift in the trigger time, resulting in an additional error in the phase measurement. Tests were conducted during a period of time when the beam current changed slowly over the course of a few minutes. The apparent change in the beam phase was plotted versus the change in beam current. The slew rate calculated from the plot determined the effect of beam amplitude jitter on the phase measurement. Normal amplitude jitter for a beam current of  $3.5 \times 10^{10}$  electrons is about 3%, or about  $1 \times 10^9$  electrons. This amount of amplitude jitter adds about 1.0 degree S-band of error to the phase measurement. The scope trigger jitter of 3.3ps is added in quadrature to the jitter produced by the beam current fluctuations. Single shot phase measurement error is therefore about 3.5 degrees S-band. After acquiring 200 samples in the histogram mode, the phase measurement error is reduced to about 0.5 degrees S-band. Phase measurement errors are also introduced by slow drifts in the beam current. However, the one degree phase error introduced for each  $1 \times 10^9$  change in the beam current is removed in the following manner. After each phase measurement, the scope is reconfigured and the amplitude of the BPM signal that triggers the scope is measured. This amplitude is compared with a reference amplitude recorded at the start of the data taking. Using the slew rate from above, a phase correction factor is calculated and applied to the current phase measurement.

### TEMPERATURE

After some initial testing, it was evident that temperature fluctuations of system components would severely limit the beam phase monitor's performance. The oscilloscope was measured to determine its temperature coefficient. Scope measurements were found to drift at a rate of  $5.4 \text{ps}/^\circ\text{C}$ . The temperature of the oscilloscope is stabilized to  $\pm 0.27^\circ\text{C}$  by placing it in an environmental chamber. Eliminating the residual drift in the scope readings produced by the remaining temperature fluctuations is accomplished in the following manner. The time domain reflectometry (TDR) capability of the scope is used to measure the propagation delay of a cable that is 30 cm long. The delay change of this cable is negligible compared to the 3.0ps TDR measurement change introduced by the scope over the  $\pm 0.27^\circ\text{C}$  chamber drift. The TDR result is a measure of the scope drift and is subtracted from the beam phase measurement.

The propagation delay change for the Andrew Corp. FSJ4-50 phase stabilized coaxial cables used to carry the BPM and RF signals to the beam phase monitor was measured to be  $0.042 \text{ps}/^\circ\text{C}$ . BPM signal cables are approximately 40 meters in length with all but 5 meters installed in the accelerator housing. The diurnal temperature swing in the housing is  $\pm 0.5^\circ\text{C}$ . The delay change for the portion of the cable in the housing is about  $\pm 0.75$  ps. As the cable leaves the housing through a penetration, it is temperature stabilized by the method outlined in the next section. There is a total of about 15m of BPM and RF signal cables in the support building that are temperature stabilized to  $\pm 0.25^\circ\text{C}$ . These cables contribute about  $\pm 0.15$ ps delay change. After converting the cable delay change to S-band degrees, the total measurement error due to cable temperature cycling is  $\pm 0.9$  degrees per day.

## LIMITATIONS

Reducing the temperature fluctuations of the system components as indicated leaves +/- 1.5 degrees of phase error per day. This value could be reduced by a factor of two by improving the temperature stabilization of the portion of the cable in the housing.

Scope trigger jitter and beam current jitter are the major factors limiting the accuracy and resolution of the phase measurements. Histogram mode is used to provide the averaging needed to achieve a measurement resolution of 0.5 degrees S-band. Increasing the sample size per measurement in an attempt to further improve the resolution was found to be ineffective. It takes about 30 seconds to complete a measurement with 200 samples, but even under ideal conditions, doubling the sample size only improves the resolution by the square root of 2. Doubling the collection time increases the likelihood of the beam being interrupted during a measurement. During recovery, a few seconds of unstable beam conditions introduce large triggering errors that quickly eliminate the benefits of the increased sample size. An optimization of sample size and collection time has produced the desired phase resolution of 0.5 degrees S-band for a sample size of two hundred. However, because the accuracy and resolution of the phase measurement depends on accurate triggering, the beam phase monitor requires stable beam conditions.

## TEMPERATURE STABILIZATION OF COAXIAL CABLES

For SLC, the control of propagation delay in coaxial cables has been accomplished by placing the cables inside double wall tubing with temperature-stabilized water flowing between the walls<sup>1</sup>. Hot and cool water were mixed so that the temperature at the pump output was kept constant. A system that operates well above ambient temperature requires only the input of heat. Such a system has been devised and tested for this project and is also being installed as part of the SLC damping ring RF feedback system.

In this scheme, control of the propagation delay of coaxial cables is accomplished by maintaining an average cable temperature. If the temperature drops in a section of cable producing a decrease in propagation delay, the entire cable temperature is raised slightly to produce an increase in delay that cancels the original change. A sensor described below measures the cable's average temperature. Heater tapes are used to heat the cable to its operating point and produce the small temperature changes which control its propagation delay. The cables, harness, and heater tapes are covered with semi-rigid foam insulation. A cut away drawing of the system is shown in figure 4.

Measuring the average temperature of the cable with a single sensor distributed over the entire cable was determined to be more effective and less costly than many discrete sensors. An RTD (resistance temperature detector) running the length of the cable was chosen as the sensor. Our goal was to produce a distributed RTD that was adjustable in length from 3 to 100 meters, and yet provide a resistance of around 100 ohms. This would insure that the wealth of temperature controllers available for use with commercial 100 ohm platinum RTDs could be used with the distributed RTD. The controller monitors the resistance of the RTD and cycles power to the heater tapes to keep the resistance constant. Standard RTDs are made from fine platinum wire with a resistance of 100 ohms at 0 °C. The temperature coefficient of the platinum generally used for RTDs is 0.00385/°C. A 100 ohm RTD will have a 0.385ohm/°C resistance change. Platinum has a high resistivity and the length of wire in typical RTD varies

from a few inches to a few feet. A larger diameter platinum wire would increase the length of the RTD, but the cost of a device 100 meters in length would be too high.

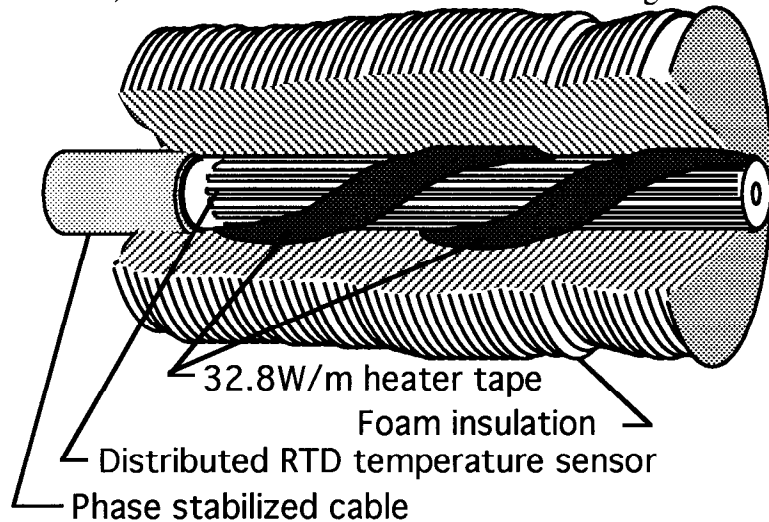

Fig. 4: Cut away of a section of temperature stabilized cable. The distributed RTD (resistance temperature detector) is connected to a standard temperature controller which measures the average temperature of the cable and cycles power to the heater tapes to keep this temperature constant.

However, copper has a temperature coefficient of  $0.00393/^{\circ}\text{C}$  which is similar to the coefficient for platinum. The resistivity of copper is about six times less than platinum, which means a copper RTD must be longer to produce the 100 ohms needed for the sensor. For these reasons, copper was chosen as the sensor material. A prototype sensor was constructed by sandwiching eight strands of 36 gauge enameled copper wire between two pieces of flexible cloth backed tape. The sensors are assembled on a jig where up to 500ft can be produced in a continuous length. The number and gauge of the strands can be varied so that when they are connected in series and in parallel, the resistance is about 100 ohms at  $0^{\circ}\text{C}$ .

Heat for the system is provided by self-regulating heater tapes manufactured by Raychem Corp. This product consists of two parallel conductors with a resistive material between them. As the temperature of the tape increases the resistance of the material between the conductors also increases reducing the current flow through the tape. This self-regulating feature prevents thermal runaway in the event of a temperature controller malfunction. This product has an output of 32.8 watts/m at  $10^{\circ}\text{C}$ . As the temperature of the cable is raised to its normal operating point of  $43^{\circ}\text{C}$ , the output of the heater tape falls to 12 watts/m. A double helix of this material is wrapped around the cable assembly with a pitch of one revolution/m, giving a total of 24 watts/m for both heater tapes. The insulating foam jacket has an inside diameter of 7.6cm and a wall thickness of 2.5cm. Using the foam's R value of 5.2 and a maximum temperature differential of  $50^{\circ}\text{C}$ , the heat loss through the insulation is 20 watts/m.<sup>2</sup>

The distributed RTD is connected to a standard temperature controller whose setpoint is set well above the highest expected air temperature. The controller applies power to the heater tapes to increase the average temperature of the coaxial cable. After the average temperature of the cable reaches the set-point, the power is cycled on and off by the controller to keep the temperature constant.

The average temperature of the stabilized cables is monitored by the SLC control system. Current from a precision power supply is passed through a second distributed RTD in the temperature sensor. The voltage drop across this RTD is measured by an

analog to digital module. The data is scaled and placed into the SLC control system history buffer<sup>3</sup>. A block diagram showing the components for control and readback of the temperature stabilized cable is shown in figure 5.

### PERFORMANCE OF STABILIZED COAXIAL CABLES

The performance of the temperature stabilized cable was evaluated by measuring the propagation delay of the cable. The beam phase monitor TDR was connected to a 10 meter piece of temperature controlled cable and the round trip travel time of the pulse was measured over several day/night periods. Results of this test are shown in figure 6. The calculated temperature change of the cable while the temperature stabilization system was functioning is about  $\pm 0.5^\circ\text{C}$ . This is based on the 20m path length of the the TDR pulse, the  $0.042\text{ps/m }^\circ\text{C}$  temperature coefficient for the cable and the  $0.4\text{ps}$  propagation delay change observed in figure 6. Tests on other pieces of stabilized cable have indicated that the temperature controller is affected by the temperature variations in the klystron gallery. This introduces an error which is about half of the  $\pm 0.5^\circ\text{C}$  variation that has been observed in this system. Tests with other controllers are planned for the future.

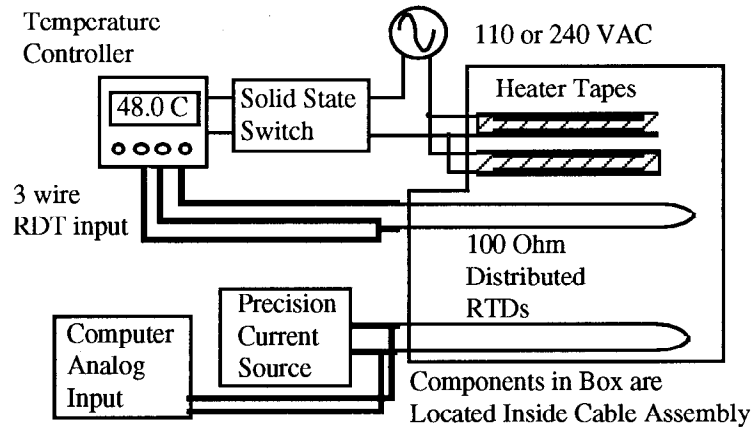

Fig. 5: Block diagram of equipment used for temperature control and readback of temperature stabilized cables. Two distributed RTDs run the length of the coaxial cable(s). One RTD is connected to a temperature controller which measures the average temperature of the cable, and cycles power to the heater tapes to maintain the desired cable temperature. The voltage drop across the second RTD is measured by an analog to digital module.

### CONCLUSIONS

The beam phase monitor has achieved the original goal of 0.5 degrees S-band phase resolution. New sampling techniques will be investigated which will reduce the need for steady beam conditions during measurements. Beam phase measurements will be made available directly to the SLC control system which will provide an on-line diagnostic to aid in beam tuning.

Initial measurements on the 10m section of temperature stabilized cable show a temperature stability of  $\pm 0.45^\circ\text{C}$ . Improvements to this performance can be realized by switching to a controller which is less sensitive to the large temperature variations

encountered in the klystron support building. Two 80m temperature stabilized cable systems have been installed which pass through three different temperature environments. Final tests of the temperature stabilization system will be conducted on these two cable installations. It is anticipated that in the future, many existing low level RF cables and new installations will be fitted with this temperature stabilization system.

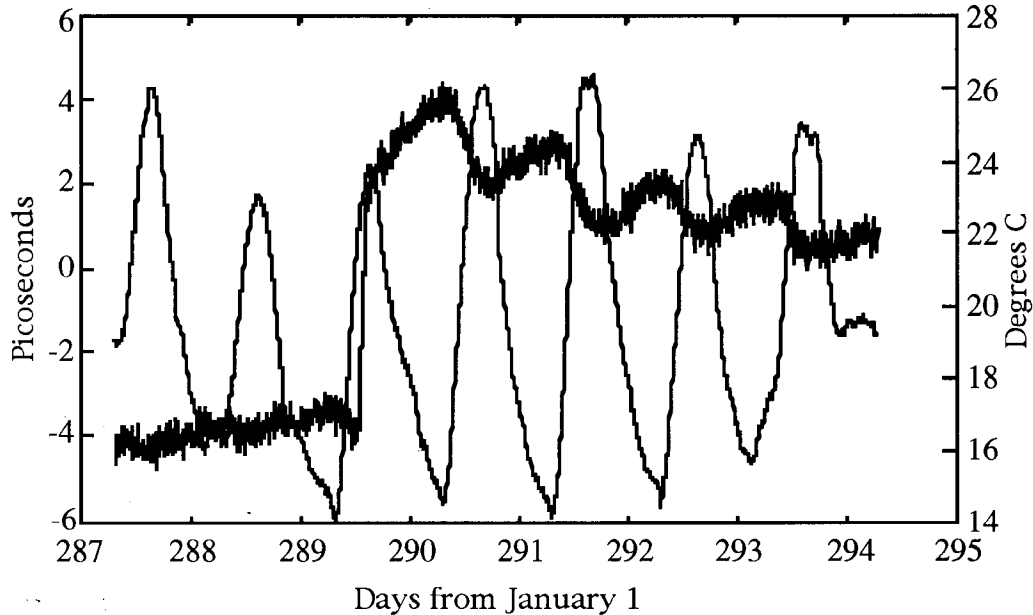

Fig. 5. Plot showing the propagation delay change in picoseconds of a temperature stabilized cable (thick trace), and the outside air temperature °C (thin trace). Results of the cable propagation delay test indicate that for a 9.5 °C air temperature swing, the propagation delay change is about 0.4ps. The stabilization system was turned off at noon on day 289. The delay change for this cable with the same air temperature variation was again measured and found to be about 1.5 ps. The reason for the slope of the plot while the stabilization system is active is not known for certain. It is believed to be a hysteresis effect due to small temperature variations in sections of the cable. The slope after the system is turned off, is the hysteresis associated with the temperature cycling of entire cable.

#### REFERENCES

- [1] K.Jobé et al, "Test Results of Sector 9 Phase Reference Line," SLAC Singal Pass Collider Memo #177, 1982
- [2] IEEE Standards Board, "IEEE Recommended Practice for the Testing, Design, Installation, and Maintenance of Electrical Resistance Heat Tracing for Industrial Applications", *ANSI/IEEE Std 515-1983*, pp 27-30
- [3] Ralph Johnson, "Stanford Linear Collider History Data Facility," Proceedings of the 1989 *IEEE Particle Accelerator Conference*, Vol.III, p. 1716.