

Linear Collider Systems and Costs*

G.A. Loew
 Stanford Linear Accelerator Center
 Stanford, CA 94309 USA

I. ABSTRACT AND INTRODUCTION

The purpose of this paper is to examine some of the systems and sub-systems involved in so-called "conventional" e^+e^- linear colliders and to study how their design affects the overall cost of these machines.

There are presently a total of at least six 500 GeV c. of m. linear collider projects [1] under study in the world. Aside from TESLA (superconducting linac at 1.3 GHz) and CLIC (two-beam accelerator with main linac at 30GHz), the other four proposed e^+e^- linear colliders [2] can be considered "conventional" in that their main linacs use the proven technique of driving room temperature accelerator sections with pulsed klystrons and modulators. The centrally distinguishing feature between these projects is their main linac rf frequency: 3 GHz for the DESY machine, 11.424 GHz for the SLAC and JLC machines, and 14 GHz for the VLEPP machine. The other systems, namely the electron and positron sources, pre-accelerators, compressors, damping rings and final foci, are fairly similar from project to project. Probably more than 80% of the cost of these linear colliders will be incurred in the two main linacs facing each other and it is therefore in their design and construction that major savings or extra costs may be found.

II. WHAT MAKES UP THE COST OF A LINEAR COLLIDER ?

The total cost (C_T) of a linear collider can be expressed as the sum of five parts:

$$C_T = C_{RD} + C_L + C_P + C_F + C_{OP} \quad (1)$$

where C_{RD} is the R&D cost of the project, C_L is the cost of all components scaling with length ($C_L = c_L L$), C_P is the cost of all components scaling with peak rf power ($C_P = c_P P_{PK}$) where c_L and c_P are per-unit costs, C_F is the fixed cost of the injectors, positron source, damping rings, compressors and final foci, and C_{OP} is the cost of operating, maintaining and powering the facility, once it is running.

Since in a linac the total energy E is proportional to $(P_{PK} L)^{1/2}$, the product $C_L C_P$ is constant for a fixed E and it can be shown that C_T has a broad minimum when $C_L = C_P$, provided that the other three costs do not dominate.

For reference, the cost of the original SLAC linac with upgrades for the 100 GeV c. of m. SLC, including salaries, and escalation from 1962-1967 to 1993 (factor of 5.7) is shown in Table I [3].

Note that the costs of some of the sub-systems such as the rectangular waveguides, valves, vacuum, supports, etc., in this table have been apportioned somewhat arbitrarily to both C_L and C_P because they are a function of machine length as well as number of power sources. The balance between C_L and C_P in the original SLAC linac was close. However, the

subsequent SLC upgrade of the linac energy from about 23 to 55 GeV which used mostly power-related components (while decreasing the repetition rate from 360 to 120 Hz) slanted the cost heavily towards C_P . Including the C_F costs in Table I but excluding the cost of the original R&D, the cost of the SLC, integrated over time, is about \$600M.

TABLE I: COST OF ORIGINAL SLAC LINAC UPGRADED TO SLC STANDARDS (INCLUDING SALARIES) 1993\$ (1967\$X5.7)

C_L (PROPORTIONAL TO LENGTH)	TOTAL	
	K\$/M	M\$
Accelerator Housing	9	26.8
Klystron Gallery	6.8	20.5
Accelerator Sections	5.1	15.4
Rectangular Waveguides, Valves, etc.	2.9	8.6
Quads, Correctors, BPMs		6.8
Vacuum, Supports, Cooling	5.7	17.1
Phase & Drive	1.9	5.7
I & C		<u>13.7</u>
		114.6
C_P (PROPORTIONAL TO POWER)		TOTAL
	K\$/Unit	M\$
245 Klystrons (24 MW; 22 kV at 360 pps)	79	19.4
245 Modulators (250 joules x 360 pps)	107	26.2
Rectangular Waveguides, Valves, etc.	35	8.6
Vacuum, Supports, Cooling	69	17.1
Phase & Drive	23	5.7
Electrical System & Utilities		31.9
I & C		<u>13.7</u>
		122.6
		M\$
$(C_L + C_P)$ unloaded		237.2
Engineering, Design and Inspection (16%)		38.0
Indirect Administrative Costs (18.5%)		43.9
Subsequent SLC Upgrades (64 MW Klystrons, Modulators, SLED, New Focusing, Beam Position Monitors, etc.)		<u>113.4</u>
$(C_L + C_P)$ loaded		432.5
C_{RD} (Original pre-construction R&D)		<u>103.2</u>
$(C_L + C_P + C_{RD})^*$		535.7

* C_F and C_{OP} are not included above. For reference, in FY 1993\$ the original SLC injector cost about \$3.2M, the two damping rings with vaults \$22.3M, the positron source \$12.8M, the arcs and final focus \$40M, the collider hall \$16M, extra controls \$24M. EDI and Indirect costs added another \$17.5M and \$16M respectively for a total C_F of \$151.8M. The annual direct operating cost of the SLC is about \$60M.

* Work supported by Department of Energy contract DE-AC03-76SF00515.

III. 500 GeV (C. of M.) EXAMPLES

To look at future machines, let us now take two "generic" examples, one at S-Band (DESY type) and one at X-Band (SLAC/NLC type), and let us first examine the specifications and block diagrams of their main linacs. The general parameters of the two machines are summarized in Table II. Note that the S-Band example is roughly ten times as long as SLAC and twice as long as the NLC. Its luminosity, compared to the NLC, is obtained by using twice the number of bunches, three times the charge per bunch and fourteen times the IP spot size, at a repetition rate of 50 Hz instead of 180 Hz. Its damping rings will clearly need greater circumferences than the X-Band example to accommodate the longer bunch trains. On the other hand, the S-Band example needs only one compressor per beam because the bunches do not have to be compressed from the pre-accelerator linac to the main linac since it will operate at the same frequency.

Fig. 1 shows a generic block diagram of an X-Band main linac module. The only difference between this case and the S-Band case is that in the latter, the klystron may drive only two accelerator structures and does not include any pulse compression. The X-Band gradient is twice the S-Band gradient.

TABLE II: GENERAL PARAMETERS OF TWO GENERIC CONVENTIONAL LINEAR COLLIDERS 500 GeV (CENTER-OF-MASS)

	S-BAND	X-BAND
RF frequency of main linacs(GHz)	3	11.4
Nominal luminosity ($10^{33} \text{ cm}^{-2}\text{s}^{-1}$)	2.4	6
Luminosity w/pinch ($10^{33}\text{cm}^{-2}\text{s}^{-1}$)	6.5	8.2
Linac repetition rate (Hz)	50	180
No. of particles/bunch at IP (10^{10})	2.1	0.65
No. of bunches/pulse	172	90
Bunch separation (nsec)	10.66	1.4
Active two-linac RF length (km)	30	14
Actual gradient (MV/m)	16.6	35.7
Beam power/beam (MW)	7.5	4.2
Total two-linac AC power (MW) [‡]	147	152
Damping ring energy (GeV)	3.13	1.8
Final Focus:		
σ_x^*/σ_y^* (nm)	400/32	300/3
σ_z^* (μm)	500	100

[‡] This is the AC power consumed by the klystrons and modulators alone. The efficiency of both S- and X-Band klystrons is assumed to be 45%, that of the modulators 80% for S-Band and 72% for X-Band. Pulse compression for the X-Band case is assumed to be about 65% efficient. Power requirements for klystron focussing supplies, pumps, vacuum, quadrupoles, etc. are not included here. They probably add another 50 MW.

Cost estimates for the two cases are shown in Tables III and IV respectively. These estimates are based on a number

of assumptions, many of which may be debatable, and some of which are discussed below:

a) The accelerator housing and klystron gallery are assumed to consist of two parallel tunnels. The cost per unit length for the two examples is assumed to be the same.

b) The cost per meter of the S-Band accelerator sections is assumed to be half that of the X-Band ones because the S-Band tolerances are looser and there are less couplers per unit length. In both cases, a large degree of automation in fabrication will be necessary.

c) The klystrons for the two examples are assumed to have equal costs: the S-Band klystrons are heavier and larger but the X-Band ones are more complex. Uncertainties exist in the focussing method and cost (R.T. or superconducting solenoids, or preferably periodic permanent magnets) as well as in possible economies of scale. Indeed, according to G. Caryotakis at SLAC, there is experience in the microwave tube industry that if a manufacturer must produce, say 1000 tubes, and starts with an increment of 10 units at a per-unit cost of X, the per-unit cost of the next 20 units will go down to 0.9X, and so on for every doubling. Hence, on such a learning curve, for 1000 tubes, the average per-unit cost would come down to about 0.6X. This would be a very favorable trend.

d) The modulators for the two examples are also assumed to have equal costs even though the X-Band ones require 40% higher average power. As suggested by R. Cassel at SLAC, it may be possible to reduce costs by sharing the power supply (Box 1 in Fig. 1) among several modules, by replacing conventional discrete PFN elements by water-filled triax lines in Box 2, and by immersing the thyatron and pulse transformer in Box 3 in a single oil tank.

e) High power prototypes for pulse compressors (SLED-II type) are not yet operational and their costs are still very uncertain.

f) Many of the other costs are patterned after escalated original SLAC costs.

We see that the S-Band machine, under the above assumptions, is about 1 Billion dollars more costly than the X-Band one, also assuming that the fixed costs (C_F) are the same for both. The dominant reason for this difference is that the S-Band linacs are twice as long as the X-Band ones. Note that this difference could be wiped out if tighter X-Band tolerances for sections, transverse alignment, klystrons, power compressors, modulators and focussing were to be much more costly than assumed, or simply, if the up-front

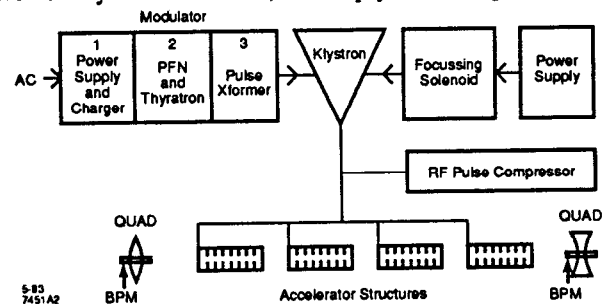

Figure 1. Generic module for main linacs.

TABLE III: COST OF S-BAND EXAMPLE
1993\$

LINACS	
Total length (km)	33
Total RF length(km)	30
No. of sections	4900
Section length (m)	6
No. of quadrupoles, correctors, BPMs	2450
Klystron peak power (MW)	150
No. of klystrons and modulators	2450

C_L		TOTAL
	K\$	M\$
Housing (double tunnel)	16/m	528
Accelerator Sections	15/m	450
Rectangular Waveguides, etc.	2.9/m	86
Quads, correctors, BPMs	30/unit	74
Vacuum, Supports, Cooling	8/m	240
Phase & Drive	2/m	66
Backward Transport Lines	2/m	66
I & C (18.5%)		<u>280</u>
		1790

C_P		TOTAL
	K\$	M\$
Klystrons	100/unit	245
Modulators	120/unit	294
Rectangular Waveguides, etc.	35/unit	86
Vacuum, Supports, Cooling	60/unit	147
Phase & Drive	30/unit	74
Utilities (200 MW)		180
I & C (18.5%)		<u>190</u>
		1216

(C_P + C_L) unloaded	3006
EDI (16%)	481
INDIRECTS (18.5%)	<u>556</u>
LINACS SUB-TOTAL	4043
C_F (rough estimate, loaded)	<u>400</u>
(C_L+C_P+C_F) loaded	4443

R&D effort at X-Band took too long. Conversely, if tunnel and other C_L costs were to be greater, the balance would tilt in the opposite direction.

One of the main reasons for carrying out this admittedly sketchy study is not simply to predict costs but rather to indicate, at an early time, where serious attention must be paid to designs so that costs may be controlled and hopefully cut drastically.

Acknowledgements

The author wishes to acknowledge useful discussions with G. Caryotakis, R. Phillips, C. Pearson, M. Munro on klystron manufacturing costs, with H. Hoag on structure costs, and with R. Cassel on modulator costs.

TABLE IV: COST OF X-BAND EXAMPLE
1993\$

LINACS	
Total length (km)	16
Total RF length (km)	14
No. of sections	7778
Section length (m)	1.8
No. of quadrupoles, correctors, BPMs	1600
Klystron peak power (MW)	94
No. of klystrons, pulse compressors and modulators	1945

C_L		TOTAL
	K\$	M\$
Housing (double tunnel)	16/m	256
Accelerator Sections	30/m	420
Circular Waveguides, etc.	5/m	70
Quads, correctors, BPMs	30/unit	48
Vacuum, Supports, Cooling	8/m	112
Phase & Drive	2/m	32
Backward Transport Lines	2/m	32
I & C (18.5%)		<u>179</u>
		1149

C_P		TOTAL
	K\$	M\$
Klystrons	100/unit	195
Modulators	120/unit	233
Circular Waveguides, etc.	35/unit	68
Pulse Compressors	50/unit	97
Vacuum, Supports, Cooling	60/unit	116
Phase & Drive	30/unit	58
Utilities (200 MW)		180
I & C (18.5%)		<u>175</u>
		1122

(C_P + C_L) unloaded	2271
EDI (16%)	363
INDIRECTS (18.5%)	<u>420</u>
LINACS SUB-TOTAL	3054
C_F (rough estimate, loaded)	<u>400</u>
(C_L+C_P+C_F) loaded	3454

References

- [1] G.A. Loew, "Toward The Next Linear Collider," SLAC *Beam Line*, Winter 1992, Vol. 22, No. 4, from a talk presented at the European Committee on Future Accelerators (ECFA) Workshop on e⁺e⁻ Linear Colliders in Garmisch-Partenkirchen, Germany, July 26-August 1, 1992.
- [2] G.A. Loew, "Review of Studies on Conventional Linear Colliders in the S- and X-Band Regime," presented at the XVth International Conference on High-Energy Accelerators in Hamburg, Germany, July 20-24, 1992. HEACC '92 Hamburg, Vol. II.
- [3] The Stanford Two-Mile Accelerator, R.B. Neal (W.A. Benjamin, Inc., 1968), chapter 4.