

POLARIZED SOURCE PERFORMANCE IN 1992 FOR SLC-SLD*

D. SCHULTZ, R. ALLEY, J. CLENDENIN, J. FRISCH, C. GARDEN,
E. HOYT, L. KLAISNER, A. KULIKOV, C. PRESCOTT, P. SÁEZ,
H. TANG, J. TURNER, M. WICKS, M. WOODS, D. YEREMIAN, and
M. ZOLOTOREV
Stanford Linear Accelerator Center
Stanford University, Stanford, CA 94309

ABSTRACT

In its initial operation, the SLC Polarized Electron Source successfully met the SLC goals for 1992 for intensity and efficiency. However, the stability of the beam at the source was marginal, and the polarization was only ~28%. The SLC goal to provide > 10,000 Z events for the SLD from polarized electrons was met.

1. Introduction

The first successful acceleration of polarized electrons to high energy was demonstrated at SLAC in 1974 using an atomic beam source¹ to generate a longitudinally polarized electron beam. Later, a photocathode polarized electron source was successfully employed in an experiment to measure parity violation.² Based on these successes, the SLC injector was designed to accommodate a new generation photocathode source, the initial operation of which is described here.

The SLC polarized electron source (PES) for 1992 consisted of a photocathode gun³ with electron transport to the SLC injector, and a flash lamp pumped dye laser⁴ with optical transport to the gun. The laser had undergone continuous improvement and testing since its installation at the SLC in the fall of 1989. The gun was installed at the SLC for the 1992 run in April, 1992; the first operation of the full source making polarized beams for the SLC began on April 19th. During the 3,980 hours of the SLC run which ended September 21st, the PES beam was delivered for > 93% of the time.

2. Gun Configuration

The same SLC diode gun and cathode were used for the entire run. The VGF (vertical gradient freeze)-grown GaAs (100) cathode, Be-doped to $2 \times 10^{19} \text{ cm}^{-3}$, had an active area of 14 mm diameter. The gun assembly is shown in Fig. 1. The cathode bias was operated at 120 kV, since experience had shown that higher voltages were more likely to result in HV breakdown after repeated photocathode cesium treatments. At this bias, the space charge limit in a 2 ns window with full cathode illumination was about $1 \times 10^{11} \text{ e}^-$. The ambient temperature for the SLC injector is 30°C. Since early tests with this gun and cathode indicated, as shown in

* Work supported by Department of Energy contract DE-AC03-76SF00515.

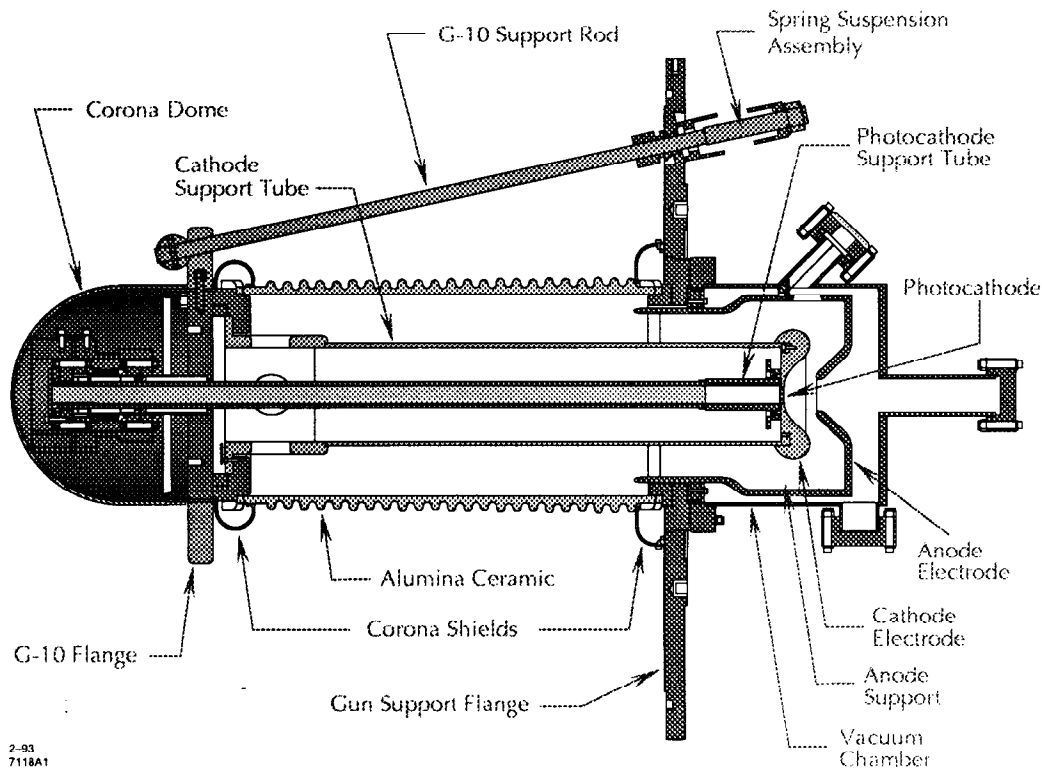

Figure 1. SLC photocathode diode gun. (See Ref. 3.)

Fig. 2, that cathode temperature could have a dramatic effect on the rate of decrease of quantum efficiency (QE), the cathode was operated at 0°C by circulating cold SF_6 in the photocathode support tube.

Except for the very highest QEs, the maximum charge that could be produced by the PES was actually limited by the "total charge limit" (CL).⁵ The CL is linear with QE, and for $\text{QE} < 6\%$, the space charge limit could not be reached even with very high laser power.

Whether limited by space charge or the CL, at high laser power the photocurrent is nearly independent of laser power. This "saturation" condition can be used to reduce the effect of jitter in the laser energy.

3. Laser Configuration

The flash lamp pumped dye laser produced a 600 ns pulse at 715 nm of 5-10 kW at 120 Hz. High power and a fairly long dye lifetime were achieved using Oxazine 720 dye. Two 2 ns pulses, separated by 60 ns were chopped from the laser pulse with a Pockels cell and crossed polarizer. The dye laser has inherently multimode transverse profile, consequently the $\sim 3\%$ intensity jitter produced by the laser itself was amplified by as much as a factor of 2 at the limiting aperture of the optical transport system. The photon density at the cathode was sufficient to operate the cathode part way into saturation as a way to produce an e^- beam in the 50-GeV linac with an intensity jitter of $\leq 2.5\%$. The two flash lamps were operated (for the most part) at a constant HV set at 16 kV, slightly above the stability threshold. This practice accounted for the relatively long lifetime of the flash lamps (averaging about 10^8 shots each). The resulting slow but steady drop in laser energy at the cathode from a high of 6-10 mJ, was compensated by a

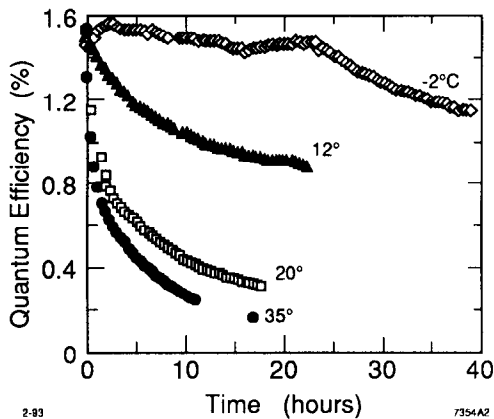

Figure 2. Temperature dependence of photocathode quantum efficiency lifetime.

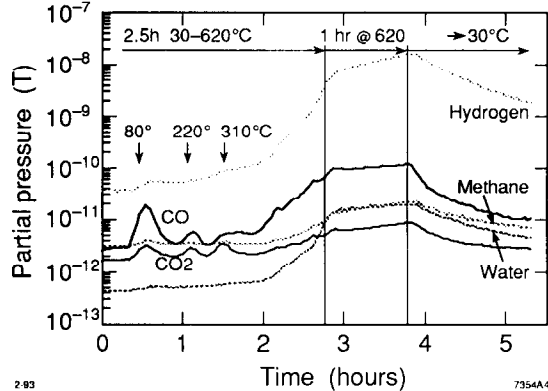

Figure 3. Partial pressures in the gun during cathode heat cleaning as measured with a VG Sensorlab RGA system.

feedback loop which removed attenuation in the optical transport system to keep the e^- beam intensity constant. The flash lamps and dye required changing every 8-10 days. The polarization of the laser light at the cathode was $\sim 99\%$.

4. Source Performance

During the period in which high energy physics was the primary SLC goal (April 24 to August 16), the PES was required to produce $6 \times 10^{10} e^-$ per bunch (all the charge in the bunch is counted here, though only about 80% of this was in the 2 ns acceptance of the SLC injector bunching system). Overall capture and transmission to the Final Focus was typically 50%. This current was readily produced by the PES as long as the QE (continuously monitored) was $\geq 3\%$ as measured at 120 kV with a low power diode laser (750 nm) using a spot size of 6 mm diameter at the cathode.

The e^- intensity was controlled as follows. The QE following a cesiation was in the range of 6-10%. The laser spot size and intensity were reduced until the desired current was achieved with the cathode partly in saturation. As the QE decreased, the laser energy at the cathode was automatically increased by the previously mentioned feedback system to keep the e^- intensity constant. When the feedback system ran out of range, it was necessary to increase the laser spot size.

Eventually the spot size was large enough that the maximum laser energy available was insufficient to provide the photon density necessary to operate the cathode in saturation. The e^- beam jitter in the linac became unacceptable. At that point, the cathode was recesiated to increase the QE, and, if necessary, the flash lamps (and dye) were changed. Typically at the turnaround point, the QE was about 3% and the laser energy at the cathode was as low as 2 mJ.

The photocathode was activated by heat cleaning at 620° C for 1 hour⁶ followed by cesiation and fluoride treatment of the room temperature cathode. The principle gas species observed during heat cleaning are shown in Fig. 3. The large CO and CO₂ peaks shown when ramping the temperature from 80 to 300° C were not present when the same cathode and gun were operated at room temperature. The cesiation technique employed was designed to minimize Cs deposition in the gun vacuum system. A standard cesiation involved having the open end of the hot Cs effusion cell, with valve open, in front of the cathode for

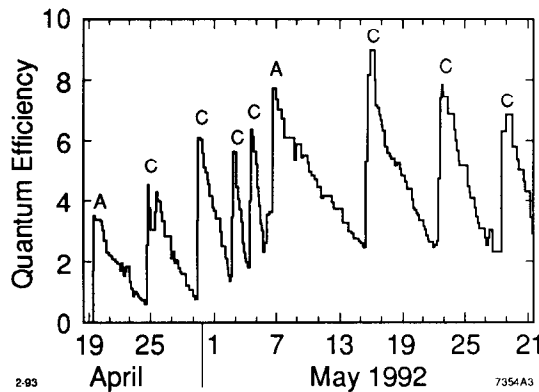

Figure 4. Quantum efficiency (750 nm and 120 kV) for first two activation cycles at the SLC injector. "A" indicates activation (heat cleaning/cesiation/fluoride), "C" indicates cesiation only. The initial QE had dropped to $\sim 3.5\%$ by the time the plot began.

~ 10 min. Based on earlier experience, it was estimated that at least 40 standard cesiations with the Cs effusion cell would be possible before HV breakdown problems would begin. It was also known that the touchup cesiations in-between activations require much less Cs. Consequently, the touchup cesiations were performed by heating the effusion cell, but keeping its valve closed. Approximately every other cesiation, the Cs valve was opened for ~ 5 s with the cell retracted. The cesium added to the gun vacuum system for the 37 touchups (including earlier laboratory work) can be ignored, unlike the 7 activations.

The QE following the first activation of the cathode surface at the SLC (there was 1 previous activation in the laboratory) was $\sim 4.2\%$. By the second activation, the initial QE had more than doubled--an unprecedented performance, to our knowledge.⁷ With the cathode temperature maintained at 0°C , the QE was observed to decrease, initially at a rate of 0.5 to 1% per day. When the beam jitter became unacceptable, as described above, the initial QE could be restored with a touchup recesiation. However, the QE declined at an ever increasing rate until, by the fourth recesiation, the rate of decrease was $> 2\%$ per day. Since for optimum SLC efficiency it was desirable not to cesiate more often than every two days, the cathode was reactivated after five cesiation cycles (about once a month). This sequence of events is illustrated in Fig. 4 for the first and second activation cycles.

Midway through the steady-state running, the cesiation technique was modified to include some "over-cesiation." This resulted in a change in the way the QE decreased following cesiation. Generally the QE would rise by 0.5-1% for the initial 24 hours, then fall at a rate of 0.5-2% per day; i.e., the trend toward ever faster decreases in QE seemed to be checked by the extra Cs during cesiation.

For the final month of the run, the required charge per bunch from the PES was increased to the order of $8 \times 10^{10} e^-$ for increased charge in the linac. To do this, the cathode was cesiated more often, which may also have contributed to an observed slower rate of fall off of QE.

5. SLC Performance

Laboratory measurements,⁸ at room temperature and low photon flux, of the polarization of this type of GaAs cathode indicated the electron polarization at the PES should have been $P_e \approx 28\%$ at high QE. Møller measurements at the end of the 50 GeV linac were consistent with a predicted polarization transmission of 92%. However, the peak polarization at the SLD, measured with the Compton

polarimeter, was only 24-25%, probably due to some depolarization in the Arcs.⁹ Typical electron polarization at SLD was 23%.

For 1992, the SLC goal was to deliver an integrated luminosity of 10,000 polarized Zs for the SLD. This goal was achieved not only because of the performance of the polarized source, but also because the SLC luminosity and efficiency for 1992 were significantly improved over that for 1991.⁹

6. Preparation for 1993

The highest priority goal is to increase the polarization of the source while maintaining the high charge and high efficiency. Polarizations $\geq 40\%$ can be achieved not only with cold VGF-GaAs, but also with room temperature, thin MBE (molecular beam epitaxy)-grown GaAs.¹⁰ The latter option depends on the successful commissioning of a new Ti:sapphire laser being built at SLAC. The CL for thin GaAs has yet to be measured. Although a polarization of about 43% can be achieved with thin AlGaAs cathodes,¹¹ the CL at achievable QEs appears to be too low. Thin GaAsP cathodes have yet to be tested at SLAC.

The very high polarizations ($\geq 80\%$) that can be achieved with strained-lattice cathodes¹² may prove to be usable before the end of the 1993 run. These new cathodes appear to have $QE < 1\%$ at the wavelength required for high polarization. The charge limit and the lifetime under SLC conditions is unknown.

A second goal for 1993 is to improve the beam stability. The new Ti:sapphire laser,¹³ which is expected to have an amplitude jitter of $\sim 3\%$ and excess power capability, operates in single transverse mode. Neither jitter amplification nor the laser power needed for operating the cathode in saturation should be a problem.

7. References

1. Cooper, P.S., *et al.*, Phys. Rev. Lett. **34**, 1589 (1975).
2. Prescott, C.Y., *et al.*, Phys. Lett. **77B**, 347 (1978).
3. Schultz, D.C., *et al.*, Proc. of the *Third European Part. Acc. Conf.*, Berlin, p. 1029.
4. Woods, M., *et al.*, "Polarized Light Sources for Photocathode Electron Guns at SLAC", this Workshop, **SLAC-PUB-5965**.
5. Woods, M., *et al.*, "Observation of a Charge Limit for Photocathode Electron Guns", this Workshop, **SLAC-PUB-5894**.
6. The surface temperature was confirmed in the laboratory by direct viewing of the cathode surface with an IRCON Modline V radiation thermometer.
7. QEs as high as 14% have been obtained in the laboratory using a load-lock system for introducing the cathode into the gun vacuum after its initial bake. See C. Garden and E. Hoyt, *Cathode Test System, Summary of Results to Date* (4/13/92), SLAC, unpublished.
8. Maruyama, T., [an inventory of photocathodes and recent experimental results] (6/19/92), SLAC, unpublished.
9. Phinney, N., **SLAC-PUB-5864** (1992).
10. Maruyama, T., *et al.*, Appl. Phys. Lett. **55** (1989) 1686.
11. Maruyama, T., *et al.*, **SLAC-PUB-5367** (1992), to be published by J. Appl. Phys.
12. Maruyama, T., *et al.*, Phys. Rev. B **46** (1992) 4261; and Aoyagi, A., *et al.*, Phys. Lett. A **167** (1992) 415.
13. Frisch, J., *et al.*, **SLAC-PUB-5950** (1992).