

Amplification and Damping of Synchrotron Oscillations via a Parametric Process*

J. D. Fox and P. Corredoura

Stanford Linear Accelerator Center, Stanford University, Stanford, CA 94309

Abstract

A two-channel mode based feedback system for the control of barycentric and π mode synchrotron oscillations in the Stanford Linear Collider damping rings is presented. This system uses a parametric amplifier/damper to control the π mode and does not require a wideband RF cavity to drive the two bunches. Laboratory results from the SLC are presented which show amplification or damping of π mode oscillations with 100–400 μ s amplitude time constants.

PARAMETRIC AMPLIFIER PRINCIPLES

The motivation for this experiment is provided by the π mode instabilities which have been observed in the SLC damping rings [1]. The damping ring design utilizes a single RF Klystron to power two accelerating cavities located roughly 180 degrees apart in the ring circumference [2]. Thus, the π mode instabilities cannot be controlled via the RF signal phase without the addition to the damping ring of an additional wideband RF cavity (active or passive) to provide correction fields of opposite sign to the two bunches [3,4].

A parametric process offers a means of coupling to a π mode oscillation, and damping two oscillators that are out of phase, without using a wideband cavity to directly drive the oscillators. Instead, by coherently modulating a parameter common to the two oscillators (the slope of cavity RF voltage) the oscillation amplitudes of the two bunches can be changed. For a simple harmonic oscillator, with resonant frequency ω_0 , and a spring constant k modulated at $2\omega_0$ ($\delta \ll 1$)

$$\omega_0 = \sqrt{\frac{k}{m}} \quad k(t) = k_0(1 + \delta \cos\{2\omega_0 t + \phi\})$$

the system equation of motion is

$$x(t) = A e^{-j\omega_0 t} e^{\alpha t} \quad \alpha = \pm \omega_0 \left\{ \frac{\delta}{4} \right\}$$

where α is positive (growing oscillations) for $\phi = \pi/2$, and negative (damped oscillations) for $\phi = -\pi/2$ [4–6].

For the case of the SLC damping rings, we calculate that a 1% AM modulation is sufficient to suppress the observed π mode with a 1 ms growth rate.

ELECTRONIC FEEDBACK SYSTEM

Figure 1 outlines the components of our two mode damping system. This system is designed to decompose

any longitudinal motion of the two bunches into some linear combination of the two normal modes (zero and π) and use the two feedback channels to control the synchrotron oscillations.

As shown in Figure 1, a pickup electrode is excited by the beam and a fast RF switch is used to separate the signal from each bunch into two processing channels. Each channel consists of a 714 MHz bandpass filter, a limiting amplifier, a mixer, and a 100 KHz bandpass filter. These channels detect the phase of each bunch with respect to the 714 MHz RF reference.

The normal modes of the two bunch system are derived from the oscillation coordinates of the individual bunches in circuitry which implements a modal matrix of the form [7]:

$$\begin{bmatrix} 0 \\ \pi \end{bmatrix} = \begin{bmatrix} C_{11} & C_{12} \\ C_{21} & C_{22} \end{bmatrix} \begin{bmatrix} \phi_1 \\ \phi_2 \end{bmatrix}$$

For coupled identical oscillators, one computes the sum and difference of the bunch coordinates. In the SLC damping rings, asymmetric bunch spacing causes the wakefields to act differently on each bunch, splitting the synchrotron frequencies. This effect (observed $\Delta\omega = 1$ kHz for $\omega_0 = 110$ kHz) requires the general modal matrix to properly separate the two modes.

The zero mode feedback signal is generated via an amplifier, phase shifter and cavity pole compensation circuit. The zero mode signal is used to drive a phase shifter in the main 714 MHz cavity drive loop.

The π mode signal is doubled such that a phase coherent $2\omega_\pi$ parametric pump signal is generated with an amplitude proportional to the amplitude of the π mode signal. The $2\omega_\pi$ signal is phase shifted via an adjustable allpass filter, and a cavity pole compensation circuit completes the feedback path to the RF amplitude modulator.

We commissioned this feedback system on the SLC north damping ring. Frequency domain studies using steady state (stored) beams were made in open and closed loop configurations using a network analyser to excite the beam. A series of time domain studies were also made using an oscilloscope to record the two mode amplitudes during transient excitations.

TIME DOMAIN STUDIES

Figure 2 shows injection transients of the two modes for three states of the feedback system. The first photograph shows the detected zero and π modes with both feedback loops open. We see that the injection process

* Work supported by Department of Energy contract DE-AC03-76SF00515.

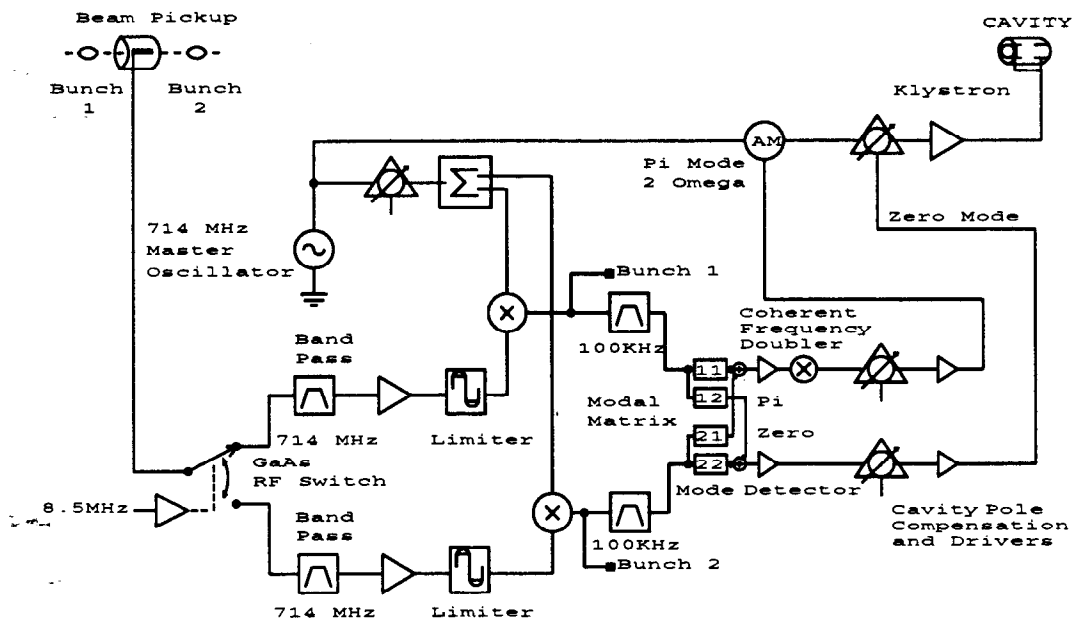

Figure 1. Block Diagram of the electronic feedback system. Two independent feedback loops control the barycentric mode (via the cavity RF phase) and the π mode (via an amplitude modulation of the cavity RF at $2\omega_\pi$).

excites both modes, and the damping time for the π mode is in excess of 1.5 ms. In the second figure both zero and π loops are closed. The transients excited by the injection into the ring are now damped, with damping times of 0.6 ms for the zero mode and 0.2 ms for the π mode. The third figure shows the transient behavior with both loops closed, but with the phase of the parametric channel adjusted to the amplifying ($+\pi/2$) state. The figure shows that the feedback system causes the π mode amplitude to grow with time. Coupling to the zero mode is also seen as the oscillation grows under the influence of the parametric amplifier.

The time behavior of the system can also be studied with stored beams. To study the π mode channel, we alternate the phase of the $2\omega_\pi$ parametric signal from the damping to the antidamping state. Figure 3 shows the control signal and the output of the π mode detector for a stable stored beam with both zero and π feedback channels turned on. We note that during the antidamping phase, the π mode is amplified, growing to nearly ± 7.5 degrees amplitude with a $400 \mu\text{s}$ growth rate. Similarly, during the antidamping phase, we see the amplitude of the oscillations reduced to approximately 2.5 degrees with a $100 \mu\text{s}$ time constant. The difference in the growth and damping rates reveals that an external damping mechanism is present in both cases, and we suggest that it is the action of the zero mode channel, acting through the imperfect mode isolation of the modal matrix, that produces this extra damping.

It was also possible to study the behavior of the parametric system by positioning the cavity tuners to select a higher order mode which excites self-sustained π mode synchrotron oscillations. In this state we varied the parametric channel loop gain over a 40 dB range and

observed the reduction in the π mode amplitude. Figure 4 shows the effect of adding loop gain in increments. We note that the extra 40 dB of gain reduces the oscillation from greater than 22 degrees to 3.5 degrees p/p but does not eliminate the oscillation. This result can be understood from the essential mechanism of parametric damping, which is that the damping rate is determined by the magnitude of the external amplitude modulation. Our feedback system generates the parametric amplitude modulation in proportion to the detected mode amplitude. With this loop configuration, as the oscillation is damped the amount of amplitude modulation is reduced. This reduction of the amplitude modulation increases the damping time of the system, and the overall effect is that the oscillation is damped to a level at which the driving terms are exactly cancelled by the damping terms, but at some fixed oscillation level. The solution to this behavior is to implement a feedback channel which provides a fixed amount of amplitude modulation (i.e., a fixed damping time) in response to a detected oscillation. With this feedback approach the residual oscillation will be damped to the noise level of the detection electronics, as for a conventional linear feedback system.

CONCLUSIONS

This series of measurements has clearly shown that the parametric mechanism can be used to excite or damp the π mode of oscillation in the SLC damping rings with 100–400 μs growth rates, and suggests that this technique shows promise for controlling these instabilities.

We are preparing to measure the performance of the parametric damper configured to produce a fixed amplitude modulation (constant damping rate system). We are also exploring the design of an adaptive system to adjust

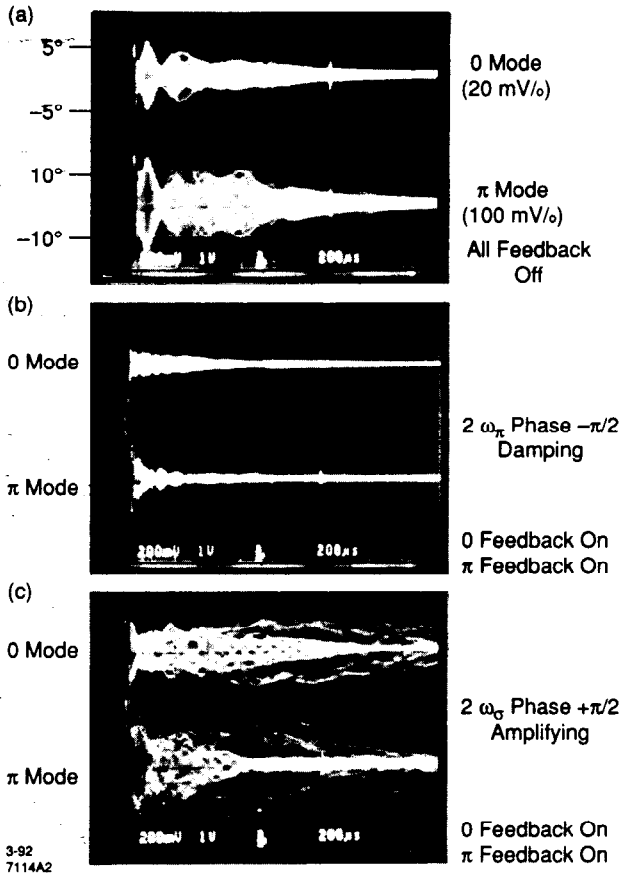

Figure 2. Zero and π mode injection transients. The top figure shows the modes with both feedback loops OFF, and the second photo shows damping of the transients under the action of the zero and π feedback loops. For the third photo the phase of the parametric loop is set to the antidamping phase, and the π mode transient is amplified by the parametric system.

the modal matrix elements automatically in response to ring configuration changes.

ACKNOWLEDGEMENTS

Perry Wilson deserves credit for first suggesting the idea of a parametric oscillator as a means of driving the π mode. We also thank G. Caryotakis, L. Klaisner, P. Morton, F. Pedersen, and H. Schwarz for their interest, and P. Krejcek, T. Limberg, and M. Ross for their help with the experiments and machine scheduling. We thank B. Noriega for his expertise in the fabrication of the proof of principle electronics.

References

- [1] Chao, Y., P. Corredoura, T. Limberg, H. Schwarz and P. Wilson, "A Feedback for Longitudinal Instabilities in the SLC Damping Rings," Conference Record of the 1991 IEEE Particle Accelerator Conference, p. 1806.
- [2] Allen, M. A., H. D. Schwarz and P. B. Wilson; "Damping Ring RF System for SLC," IEEE Trans. Nucl. Science Vol. NS-30(4) p. 3447, 1983.
- [3] Corredoura, P., J.-L. Pellegrin, H. D. Schwarz and J. C. Sheppard, "An Active Feedback System to Control Syn-

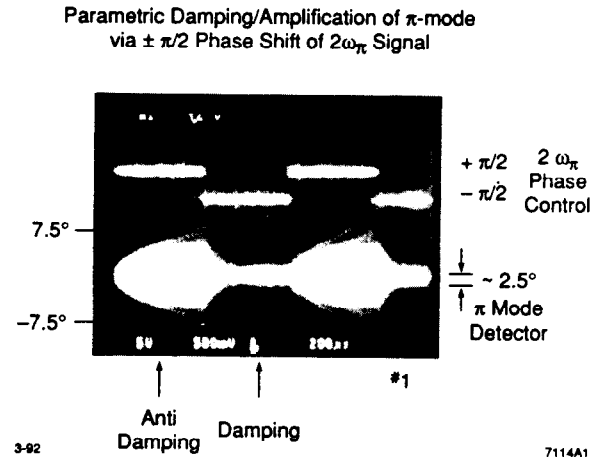

Figure 3. Time behavior of the π mode oscillation under phase modulation of the $2\omega_\pi$ pump signal. During the antidamping phase the oscillation grows, and during the damping phase the oscillation amplitude decays.

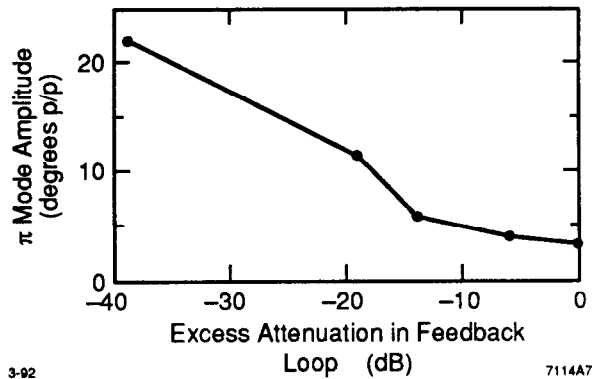

Figure 4. Magnitude of a steady-state π mode oscillation vs. excess attenuation added to the feedback loop. With -39 dB loop gain the oscillation amplitude saturates the detector and is greater than 22 degrees p/p. Feedback reduces the steady-state oscillation to 3.5 degrees p/p.

- chrotron Oscillations in the SLC Damping Rings," Proceedings of the 1989 IEEE Particle Accelerator Conference, p. 1879.
- [4] Heins, D., R. D. Kohaupt et al., "Wide Band Multibunch Feedback Systems for PETRA," DESY 89-157, 1989.
- [5] Louisell, William H., "Coupled Mode and Parametric Electronics," Wiley, 1960.
- [6] Brandt, Locherer, "Parametric Electronics," Springer-Verlag, 1981.
- [7] Fetter, A. and J. Walecka, "Theoretical Mechanics of Particles and Continua," McGraw-Hill, 1980.