

LESSONS FROM THE SLC FOR FUTURE LC CONTROL SYSTEMS*

Rusty Humphrey

Stanford Linear Accelerator Center, Stanford University, Stanford, CA 94309

The SLC control system is the dynamic result of a number of forces. The most obvious force is the functional requirements of the SLC itself, but other forces are history, budget, people, available technology, etc. The plan of this paper is to describe the critical functional requirements of the SLC which caused significant development of the control system. I have tried to focus on functional requirements as a driver, and I will describe some solutions which we have implemented to satisfy those requirements.

The important functional requirements drivers for the control system discussed in this paper are:

- ⇨ Repetition rate
- ⇨ Sensitivity to orbit distortion
- ⇨ Stability/Automation
- ⇨ Accelerator Development

REPETITION RATE

The SLC runs for physics production at 60 or 120 Hz. At 120 Hz, 5×10^{10} particles per bunch, 3 bunches/beam pulse, and 50 GeV, the average power is 150 kW. If the beam has a small enough cross sectional area, such a beam has caused damage to beam vacuum pipes, beam vacuum flanges, collimators, or other beam line components by heating. Such events occur because the beam has become "errant"; that is, it has wandered from its nominal orbit, and is actually striking the device. If this situation is not detected, then more and more energy is put into the device, as the SLC pulses keep coming. The first issue is to detect the event, and turn off the beam. There are a number of classic methods of such detection (ion chambers, beam current comparators, etc.), and the SLC uses them.

Once the event is detected, how does one fix the problem? Usually the answer is to steer or tune the machine. But now a situation, which appears as a form of "relaxation oscillator," happens. To tune the beam, one needs beam in the machine. But because the beam is mistuned, the machine protection system detects the same problem again and turns off the beam again. How does one break this impasse?

The first, and obvious answer is to tune at a lower beam intensity; instead of running with 5×10^{10} particles, tune with 2×10^{10} . This doesn't work in general. The SLC

with 2×10^{10} particles is a sufficiently different machine from the SLC with 5×10^{10} particles that the problem often disappears at 2×10^{10} , only to reappear when the current is raised to 5×10^{10} .

The next answer is to tune at the same beam pulse intensity, but to lower the repetition rate. This is, in fact the technique that is used at the SLC. However, it does not work to simply lower the repetition rate of all components in the machine to 10 or even 1 Hz. Power is dissipated in the rf and pulsed magnet systems, and lowering the repetition rate in such components changes their characteristics. Therefore, an effective rate limiting strategy requires that the rate of running the pulsed components of the machine not be changed, but that only the injection of electrons and positrons be moved to the lower rate.

The above discussion is an overview of the simplest situation; and even it isn't really simple—how the creation and injection of positrons is handled is problematic even in this situation. More complicated scenarios are also possible in the SLC [1].

Another issue for the Machine Protection System is configuration flexibility. As the SLC configuration is changed during tuning or machine studies, the requirements on machine protection change. An obvious example is a repetition rate change from 60 to 120 Hz. A less obvious example is changing the place where the beam is stopped. It is a requirement of the machine protection system that it react to such configuration changes in as seamless a manner and as prompt as possible. At the SLC, this functionality is provided by means of the timing system, which includes distribution of timing "patterns" which allow pulse to pulse timing configuration changes. This functionality is being augmented because it is required by a project to upgrade our present Machine Protection System [2], and because it is needed for the next phase of our Fast Feedback system.

To summarize the functional requirements: The repetition rate for a linear collider can allow errant beam to damage or destroy beam line components. A protection scheme is required which detects such situations, which limits the beam, and which allows retuning of the machine to stop the situation. It is required that retuning be done at or near the beam conditions which cause the errant beam. In addition, the machine and its machine protection system must be easily and quickly reconfigurable.

* Work supported by Department of Energy contract DE-AC03-76SF00515.

SLC WEST
Profile Monitors

Jan. 1989

Critical units
underlined

Index to abbreviations

ΔE - used for energy spread monitoring

ϵ - used for emittance ($\eta=0$)

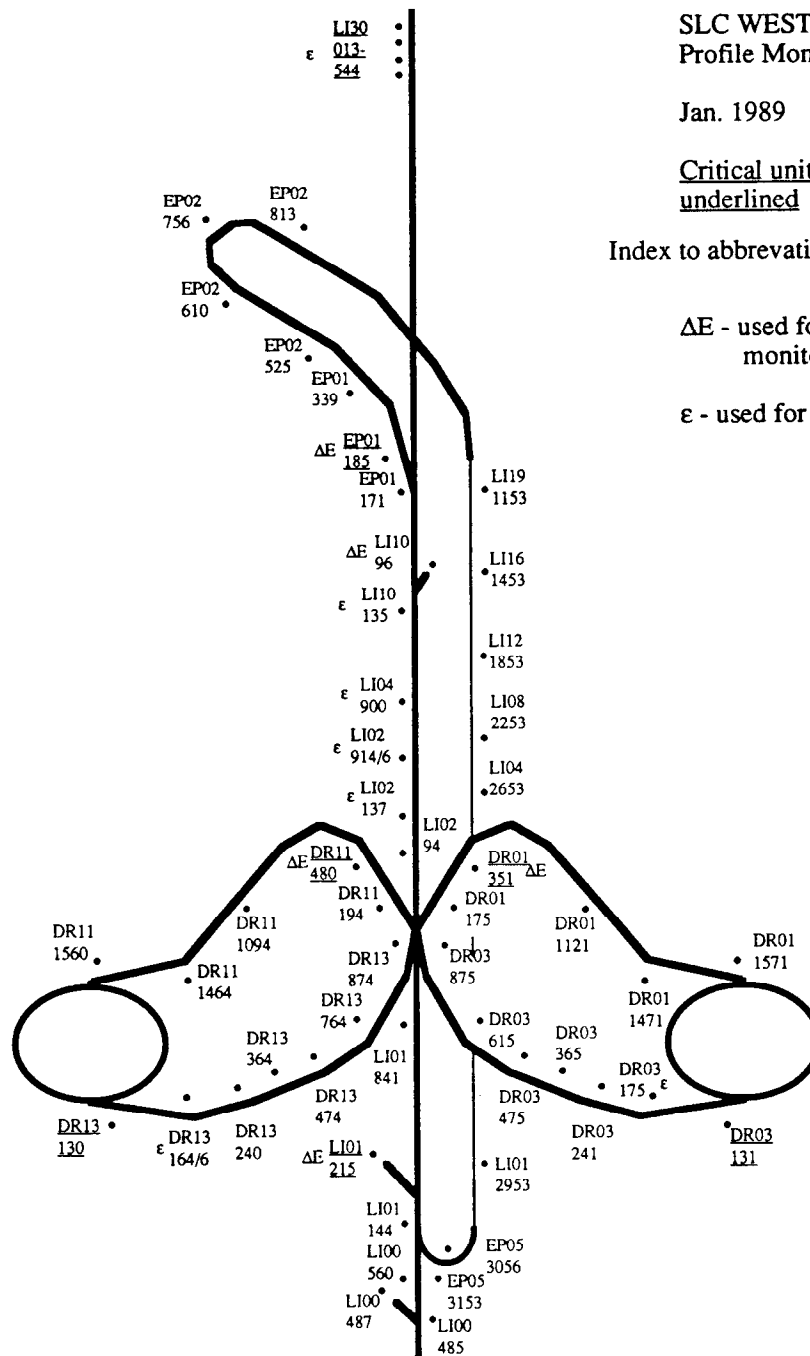

Figure 1. Location of beam profile monitors in the SLC injector, damping rings, linac and positron production systems.

SENSITIVITY TO ORBIT DISTORTION

In the SLC, emittance and other parameters of the beam are affected by orbit distortions. One easy way to understand this is to remember that wake field tails are caused by off axis beams in the linac's disk loaded wave guide. As a result of this sensitivity, the mix of beam diagnostic systems required for the SLC is affected. Diagnostics which measure beam shape, beam size, and emittance are many. As shown in Figures 1 and 2, there are

approximately 100 beam profile monitors and 37 wire scanners.

The beam profile monitor system has been described elsewhere [3]. As noted there and elsewhere [4], the use of profile monitors is destructive to the beam, but they allow shape changes to be observed in real time and give detailed information of transverse tail formation. (See Figure 3.) In concert with an adjustable upstream quadrupole, beam profile monitors can be used to measure emittance [5].

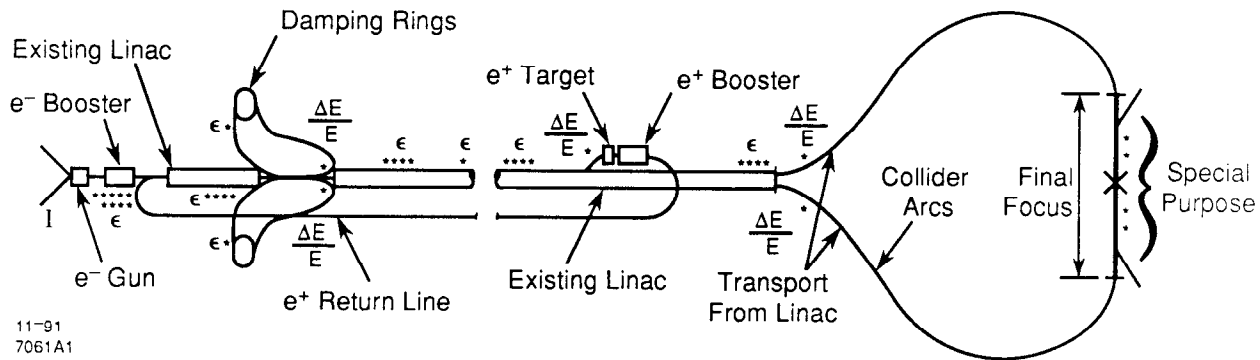

Figure 2. Location of wire scanners in the SLC.

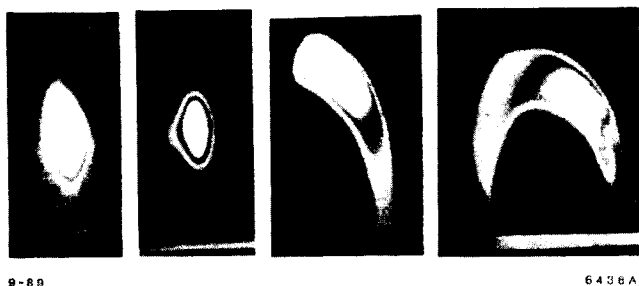

Figure 3. Images of an electron bunch on a profile monitor at 47 GeV showing wakefield growth with increasing oscillation amplitudes. The images from left to right are for a well-steered beam, a 0.2 mm oscillation, 0.5 mm oscillation and a 1.0 mm oscillation, respectively. The beam intensity is 2×10^{10} electrons. The core sizes σ_x and σ_y are about 120 mm.

The wire scanners have been discussed elsewhere [6]. The beauty of wire scanners is that they allow nondestructive measurement of the beam emittance, and thus could be used as an online device in, for example, beam feedback systems (we have not yet done so).

John Seeman has pointed out the need for what he calls "corroborating measurements." As an example of what this term means, consider the fact that emittance can be measured by both profile monitors and wire scanners. The presence of two techniques allows the results of such measurements to be compared. If the measurements are equivalent, then they corroborate (or confirm) one another. This increases the credibility of the results—an important factor in a prototype accelerator.

Beam position monitors (BPMs) used in the SLC number approximately 1700. All the BPMs in the linac itself are instrumented for single pulse data acquisition; every BPM so instrumented can be read out, under control of the timing system, on any given pulse for a particular beam bunch. BPM systems in the SLC arcs and in the damping rings have multiple BPMs which are multiplexed into a common data acquisition module; this precludes reading all the BPM inputs into one of these

modules on the same beam pulse. However, over the past year, we have had a couple of projects to "demultiplex" BPMs; that is, to instrument more BPMs in the same way as the linac BPMs so that orbit measures on a single beam pulse can be done. The builders of future linear colliders need to look carefully at the requirements for single pulse orbit measurement.

The impact of these beam diagnostic systems on the control system is large. Fundamentally, the data acquisition requirements for a linear collider correspond to that of the "first turn" for a circular collider. The ability to take a single pulse "snapshot" of the orbit, or a snapshot of many parameters associated with the beam or with individual pulsed devices is a requirement. As the references detail, emittance and beam shape measurements require sophisticated image processing and accelerator matrix manipulation and fitting. As the maps of profile monitors and wire scanners show, and as the number of BPMs implies, these systems are everywhere, and time spent on generalization and sophistication is well spent.

To restate the functional requirement: linear collider operation requires careful attention to diagnostics which measure beam orbit position and distortion, emittance, and beam shape.

STABILITY, AUTOMATION

The SLC is a large complicated device. Stability of the SLC is a large problem. Feedback systems, in which the control computer system is an active component of the feedback loop, have been operational at the SLC since 1988. Feedback based on signals derived from beam diagnostic instrumentation allows a much higher degree of control over the beams, since these data can be acquired from many sources and statistically fit. Single device tolerances could never provide this level of stability. The main application of these feedback systems is steering (launch angle and position); but feedback systems to correct energy, energy spread, and collision point are also used.

The earliest version of these was "slow feedback," with update times measured in tens of seconds; such loops are closed through the VAX mainframe which is the highest hierarchical level in the SLC control system. This was quickly augmented by prototype pulse-to-pulse feedback ("fast feedback") systems using a dedicated microprocessor based system, instrumentation, and controlled steering supplies. This prototype system was a very successful, but could only be replicated with difficulty and was difficult to maintain. We have since generalized this prototype and integrated it into the SLC control system. That generalization is propagating at a rapid rate to a large number of installations in the SLC, replacing both the prototype version of itself as well as many of the older "slow feedback" applications. This system is described in another paper being presented to this conference [7].

One of the major benefits of these fast feedback systems is the step forward in automation that they allow for accelerator operations. As described elsewhere [8], the SLC control system logs a number of different events on a continuing basis. One such class of events logged is "knob turns"; i.e., each time an operator turns a software-defined knob, that event is logged. As a result, we know that fast feedback has decreased the required intervention of operators to do knob turns by as much as 80%; fast feedback is doing the knob turning for us.

ACCELERATOR DEVELOPMENT

The SLC is the prototype for a linear collider. The SLAC staff is working to understand how a linear collider works. One of the SLC accelerator physicists has noted that "...there are more interesting accelerator physics tests being proposed each day than there is accelerator time to perform them" [4]. The environment is such that there are numerous questions to be answered and there is often the need find answers *quickly* so that the answers can be incorporated into operation. It is an essential functional requirement that the control system supply

tools that allow the staff to do machine physics experiments which have never before been even considered.

The major tool—actually a set of tools—for this is the Correlation Plot Facility, described in a poster session paper of this conference [9]. This powerful software provides a set of tools for realtime online analysis, fitting, plotting, control and measurement of a large number of variables. The facility is well integrated into the SLC control system, and programs or functions which are developed for physics studies are often incorporated into operational software [10].

This functional requirement will exist for the next linear collider, since it will be built on an experience base of one—the SLC.

COMMENTS

The control system for an accelerator must satisfy many functional requirements—many more than the four described above. These four were described because SLAC's experience shows that they are, in some way, unique to the class of linear colliders.

There are other functional requirements which are common to all accelerators. And there are functional requirements which are unique to the SLC—a prototype linear collider based on the existing SLAC linac. Neither of these classes of functional requirements have been discussed, although some of the solutions described above help to meet them.

The four functional requirements described above have been a challenge which has been met by a large team of highly committed people. Some of that team is named in the references, but there are many, many more. I would like to thank Marty Breidenbach, Ewan Pater-son, Nan Phinney, Marc Ross, John Seeman, and John Sheppard for recent discussions on this topic.

REFERENCES

- [1] For a further discussion, see M. Ross, "Machine Protection Schemes for the SLC," 1991 Particle Accelerator Conference.
- [2] S. Clark, A. Grillo, N. Spencer, D. Hutchinson, J. Olsen, D. Millsom, G. White, T. Gromme, S. Allison, K. Underwood, M. Zelazny, and H. Kang, "Smart Machine Protection System," *Proceedings of the International Conference on Accelerator and Large Experimental Physics Control Systems*.
- [3] M. C. Ross, "Beam Diagnostics and Control for SLC," 1987 Particle Accelerator Conference.
- [4] J. T. Seeman, "The Stanford Linear Collider," SLAC-PUB-5607.

- [5] M. C. Ross, N. Phinney, G. Quickfall, H. Shoaee, and J. C. Sheppard, "Automated Emittance Measurements in the SLC," 1987 Particle Accelerator Conference.
- [6] M. C. Ross, J. T. Seeman, E. Bong, L. Hendrickson, D. McCormick, and L. Sanchez-Chopitea, "Wire Scanners for Beam Size and Emittance Measurements at the SLC," 1991 Particle Accelerator Conference.
- [7] L. Hendrickson, S. Allison, T. Gromme, T. Himel, K. Krauter, D. Nelson, F. Rouse, R. Sass, and H. Shoaee, "Generalized Fast Feedback System in the SLC," *Proceedings of the International Conference on Accelerator and Large Experimental Physics Control Systems*.
- [8] N. Heinen, N. Spencer, and J. Tinsman, "Improving the Reliability in the SLC Control System," 1989 ICALEPCS Proceedings.
- [9] L. Hendrickson, N. Phinney, and L. Sanchez-Chopitea, "The SLC Correlation Plot Facility," *Proceedings of the International Conference on Accelerator and Large Experimental Physics Control Systems*.
- [10] For example, M. C. Ross, N. Phinney, G. Quickfall, H. Shoaee, and J. C. Sheppard, "Automated Emittance Measurements in the SLC," 1987 Particle Accelerator Conference.