

HIGH CURRENT TRANSISTOR PULSE GENERATOR*

V. Nesterov, R. Cassel
 Stanford Linear Accelerator Center, Stanford University, CA 94309

Abstract

A solid state pulse generator capable of delivering high current trapezoidally shaped pulses into an inductive load has been developed at SLAC. Energy stored in the capacitor bank of the pulse generator is switched to the load through a pair of Darlington transistors. A combination of diodes and Darlington transistors is used to obtain trapezoidal or triangular shaped current pulses into an inductive load and to recover the remaining energy in the same capacitor bank without reversing capacitor voltage. The transistors work in the switch mode, and the power losses are low. The rack mounted pulse generators presently used at SLAC contain a 660 microfarad storage capacitor bank and can deliver 400 amps at 800 volts into inductive loads up to 3 mH. The pulse generators are used in several different power systems, including pulse to pulse bipolar power supplies and in applications with current pulses distributed into different inductive loads. The current amplitude and discharge time are controlled by the central computer system through a specially developed multichannel controller. Several years of operation with the pulse generators have proven their consistent performance and reliability.

I. INTRODUCTION

To deflect particle beams in an accelerator with the help of deflecting magnets different "flat top" pulse generators are frequently employed. Transistor Pulse Generators described in this article are found in use at SLAC in applications where relatively low voltage low current and slow kickers are required. Attractive features of these pulse generators are their simple configuration, compactness and reliability.

II. BASIC CIRCUIT DESCRIPTION

Fig. 1 shows a simplified schematic of a basic Transistor Pulse Generator. Initially the storage capacitor C is resistively charged to 800 volts from a direct current power supply. To produce a trapezoidal pulse current into an inductive load L, both transistors Q1 and Q2 are turned on simultaneously and the storage capacitor C starts to discharge into the inductance L. The loop current is constantly compared through a feedback mechanism to the desired reference value and as soon as it reaches the specified level one of the Darlington power transistors, for example Q1, is turned off. The current which is present in magnet L will continue to flow through the magnet, but using a different electrical route, freewheeling through a diode D1 and a still conducting transistor Q2, thus making the flat top portion on the magnet current pulse. Finally the second transistor Q2 is turned off, and the remaining current

is redirected into capacitor bank C through diodes D1 and D2. The 800 volts d.c. power source recharges the capacitor C voltage back to its original value, making up for energy losses during the charge/discharge cycle. The important feature is that the voltage across the capacitor C never reverses its polarity. Fig. 2 shows the waveforms in various parts of the circuit. Fig. 3 shows a variation of the basic circuit. In this configuration the resistive high voltage charging circuit for the storage capacitor is replaced with a low voltage series connected d.c. source. The voltage across the capacitor, initially at zero, builds up to a value several times large than E, through cumulative charging, after several pulsing cycles. The final stable operating voltage and current depend on the Q of the circuit.

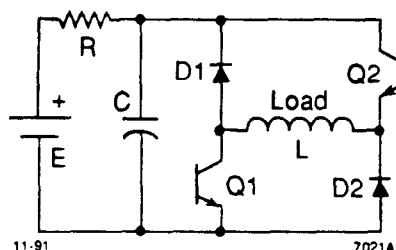

Figure 1

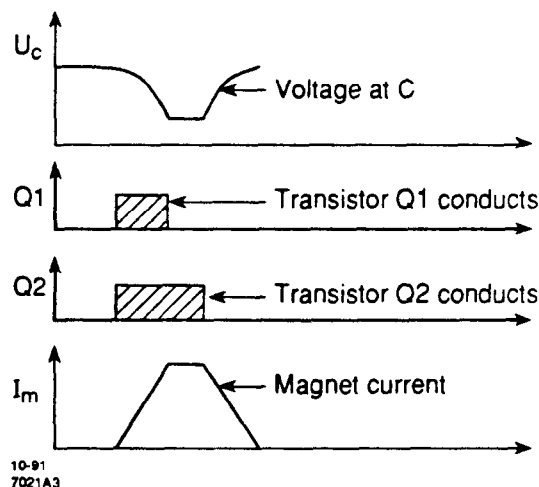

Figure 2

III. VOLTAGE DOUBLER SERIES CONNECTION

The highest operating voltage of the Transistor Pulse Generator is limited by the rating of transistors Q1 and

* Work supported by Department of Energy contract DE-AC03-76SF00515.

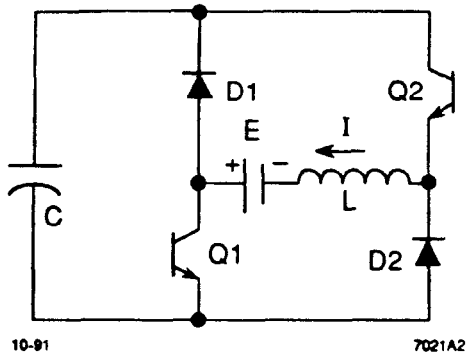

Figure 3

Q2: When more voltage is needed to achieve the required current in an inductive load a series connection of the Pulse Generators may be utilized to double the magnet voltage. Fig. 4 shows such a connection for the case of an inductive load without a mid-point tap, using two pulse generators. Both storage capacitors C1 and C2 are charged in parallel from the same d.c. power supply. The reverse diodes built into the Darlington transistors provide a path for the capacitor charging current. The series discharge of the storage capacitors C1 and C2 is achieved by simultaneously turning on all power transistors. Turning off any one of the transistors in both pulse generators will produce a flat top in the current pulse. And when all transistors in both generators are turned off the capacitors C1 and C2 will be connected in parallel to the inductive load through the D1, D5 and D3, D6 diodes. Because of this series discharge and parallel recharge of the two pulse generators, during the capacitor recharge period the inductive load sees only half the voltage it sees during the capacitor discharge period. The result is that the falling edge of the current pulse is twice as long as the rising one, as illustrated in the Fig. 5.

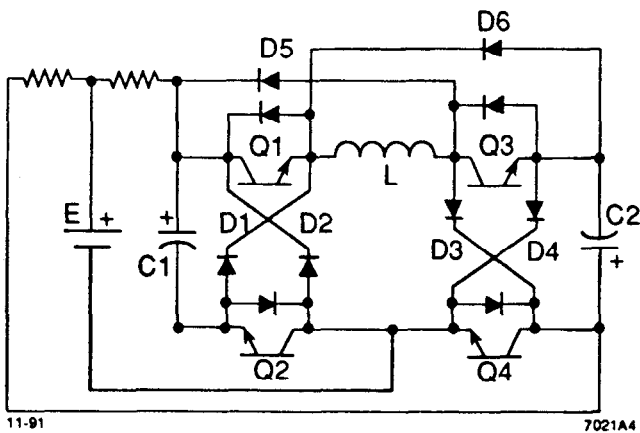

Figure 4

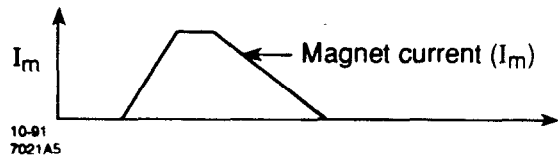

Figure 5

The series connection of two pulse generators for the case of a load with a mid-point accessible is shown in Fig. 6. In this configuration both capacitors C1 and C2 are discharged and recharged in series. Balance of the voltage between the two pulsers is maintained due to a transformer effect of the mid-point connection. The current pulse waveform for this configuration is shown in Fig. 7.

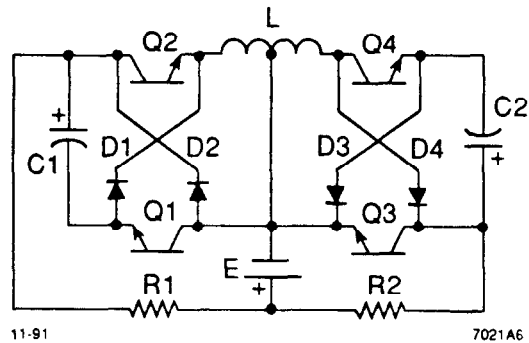

Figure 6

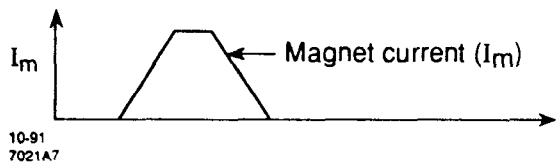

Figure 7

IV. BIPOLAR CONNECTION

Figure 8 shows two Pulse Generators connected not as a voltage doubler but in bipolar configuration. The Pulse Generator Controller has a special provision to insure that only one Pulse Generator is fired at any one time.

V. DESIGN CONSIDERATIONS

All the Transistor Pulse Generator components are typically contained in a single rack mounted chassis with the following dimensions: 19" wide, 12" high and 20" deep.

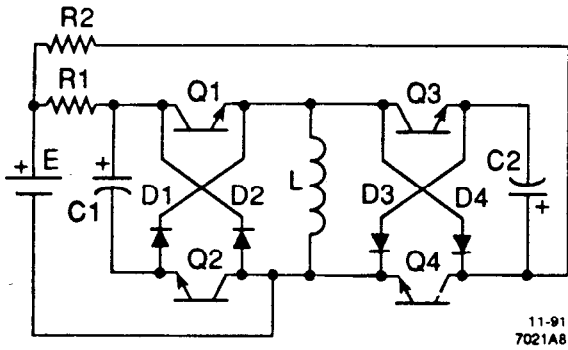

Figure 8

Darlington transistor modules and diode modules for Pulse Generators are mounted on a common water cooled heatsink. Particular attention was given to a mechanical layout of the Pulse Generator chassis to minimize the influence of all parasitic inductances during the transient

period of Q1 and Q2 transistor switching. Snubber networks and varistors are used across all power transistors to protect them from transient overvoltages. A crowbar protection SCR was also installed at the Pulse Generator output. A four channel Pulse Generator Controller and a four channel SCR Distributor, both developed at SLAC, allow the user to operate up to four independent inductive loads, selecting any one on a pulse to pulse basis.

VI. CONCLUSION

In several years of experience of continuous use these Transistor Pulse Generators have proved themselves to be easily serviceable and reliable sources of pulse power.

VII. ACKNOWLEDGEMENTS

The authors would like to thank Minh Nguyen for participation in the design of the Pulse Generator Controller, Scott Hewitt for technical support and Martin Berndt for his very valuable comments and editing help.