

**THE COMPLETED DESIGN OF THE SLC FINAL FOCUS SYSTEM\***

J. J. MURRAY, K. L. BROWN AND T. FIEGUTH

Stanford Linear Accelerator Center  
 Stanford University, Stanford, California 94305

**1. Summary**

The design of the SLC Final Focus System has evolved from its initial conceptual design<sup>1,2</sup> into its final form. This final design is described including a review of the critical decisions influencing the adoption of particular features. The creation of a feasible design has required that these decisions be tempered by practical considerations such as site constraints, correction of optical errors caused by imperfections, and accommodations requested by engineers and particle detector physicists. As this is the first such system to be built, it is hoped that the experience gained will be useful for the design of future systems.

**2. Introduction**

The part of the SLC between the ends of the arcs and the Interaction Point (IP) are called the Final Focus Systems (FFS). Overall, the functions of the FFS are to transform the beams at the ends of the arcs so as to form dispersion-free, round beams at the IP. This 1<sup>st</sup> order beam size is optimized to yield the maximum possible luminosity when the effects of various perturbations and aberrations have been accounted for and when 1<sup>st</sup> and 2<sup>nd</sup> order optical corrections have been applied. Site limitations required that length conserving measures be taken.

The FFS for electrons and positrons are essentially the same, each consisting of four subsystems as indicated in Fig. 1.

The functions of these subsystems are as follows:

**THE FINAL FOCUS BEND (FFB)**

- Removes dispersion which at the ends of the Arcs is given by  $\eta_x = 0.0474\text{m}$  and  $\eta'_y = \eta'_x = \eta'_y = 0$ .
- Transfers the Arc beams (with  $\beta_x = 8.70\text{ m}$   $\beta_y = 1.14\text{ m}$  and  $\alpha_{x,y} = 0$ ) to the next subsystem with a transfer matrix equal to the negative identity matrix.
- Provides a large, achromatic bend needed to satisfy global geometry constraints.
- Provides quad/skew-quad pairs separated in phase by  $\sim \pi/2$  to remove the accumulated anomalous dispersion at the IP due to perturbations in the Arcs and FFS.

**THE INITIAL TRANSFORMER (IT)**

- Initiates demagnification, and provides a round beam, with  $\beta_{x,y} = 0.12\text{ m}$  and  $\alpha_{x,y} = 0$ , to the next subsystem.
- Provides trims on the two last quadrupoles to adjust  $\beta_{x,y}$  at the IP.
- Provides a region where the  $e^+, e^-$  pathlength difference was adjusted.

**THE CHROMATIC CORRECTION SYSTEM (CCS)**

- Corrects the dominant 2<sup>nd</sup> order chromatic aberrations at the IP without significantly introducing others.
- Provides s bend geometry to reduce synchrotron radiation (SR) background in the particle detector.
- Provides space for a low field *soft bend* magnet to further reduce SR background.

**THE FINAL TRANSFORMER (FT)**

- Completes the demagnification process. The magnification in this transformer is the same in the  $x$  and  $y$  planes, so that at the IP the ideal beam is round, with an optimum  $\beta_{x,y}^* = 0.0075\text{ m}$  and  $\alpha_{x,y} = 0$ .
- Allows independent adjustment of the axial position of the beam waists to match the position of temporal coincidence at the IP. This is done by trimming QD2B and QF3 quadrupoles (see Fig. 1).
- Provides a skew quad for suppression of cross-plane coupling between  $x, y'$  and  $x', y$  at the IP.

**Details of the FT Design**

This is the most critical subsystem of the FFS in terms of sensitivity to chromatic aberrations, misalignments and other errors. Described below is the procedure that led to the adopted design. It is based on the attractive symmetries that occur when symmetric quadrupole triplets are used as building blocks. A basic optical model was adopted consisting of two quarterwave sections in series which form a halfwave transform with a diagonal transfer matrix given by the equation:

$$\begin{pmatrix} 0 & F_{2x,y} \\ -1/F_{2x,y} & 0 \end{pmatrix} \begin{pmatrix} 0 & F_{1x,y} \\ -1/F_{1x,y} & 0 \end{pmatrix} = \begin{pmatrix} -M_{x,y} & 0 \\ 0 & -1/M_{x,y} \end{pmatrix} \quad (1)$$

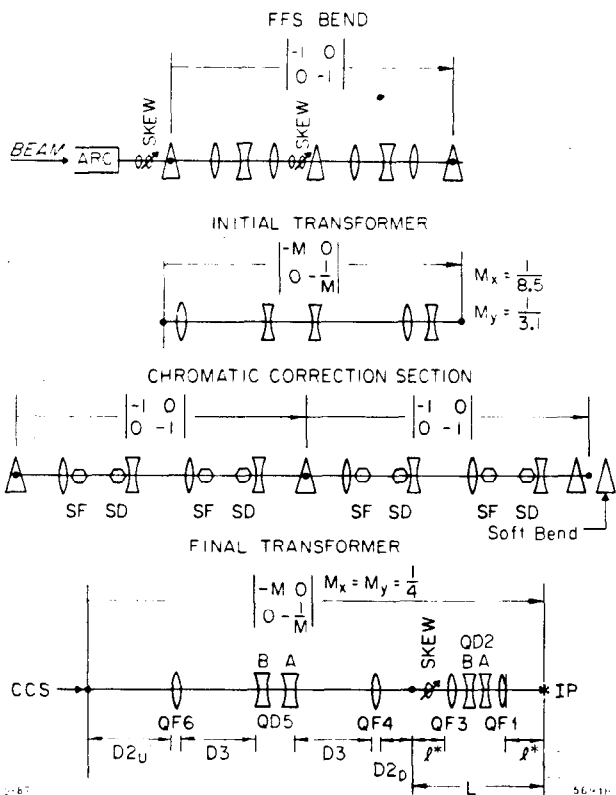

Fig. 1. Schematic of the SLC Final Focus System.

\*Work supported by the Department of Energy, contract DE-AC03-76SF00515.

where  $M_x = F_{2x}/F_{1x}$  and  $M_y = F_{2y}/F_{1y}$ . For the SLC

$$M_x = M_y = M \quad (2)$$

Consider the quarterwave section nearest the IP (see Fig. 1). It consists of a close-packed symmetric triplet with equal drifts,  $\ell^*$ , on both ends. This close-packed feature was adopted to conserve overall length which is of special significance in the final transformer where the 2<sup>nd</sup> order chromatic aberrations,  $T_{126}$  and  $T_{346}$ , are very large each with a magnitude approximately equal to the overall length of the *unreduced* configuration (defined below). The center quadrupole is split in half longitudinally to avoid impractical length/bore ratios. All four quadrupoles have the same bore and pole tip field, to utilize the maximum practical gradient and to permit powering them in series.

The minimum value for the drift  $\ell^*$  between the downstream face of QF1 and the IP depends on the particle detector requirements. For conventional quadrupoles and the MKII detector,  $\ell^*$  must be  $\geq 2.8$  m for QF1 to clear the stray field of the detector solenoid. For this value of  $\ell^*$  it is estimated that a quadrupole bore radius of about 2 cm is required to clear both the charged and neutral components of a fully disrupted beam. In turn, a maximum allowable pole tip field, conservatively chosen as 10 kg for conventional quadrupoles, determines the maximum common field gradient of the triplet magnets.

Leaving  $\ell^*$  and the common gradient fixed, and taking advantage of the chosen fore/aft symmetry, two free parameters (the equal lengths of QF1 and QF3 and the equal lengths of the QD2's) are sufficient to generate the desired quarterwave section with length  $L$ .

Now, consider the upstream quarterwave section. Scaling the quarterwave section just found (all lengths by  $1/M$  and the common gradient by  $M^2$ ) and combining the two sections satisfies Eq. (1). With  $1/M \sim 4$  or 5, however, this leads to an excessive overall length and excessive lengths of individual quadrupoles. We will refer to this as the *unreduced* configuration with overall length  $L_o$  given by,

$$L_o = \left(1 + \frac{1}{M}\right) L \approx 50 \text{ m} . \quad (3)$$

Steps are now taken to reduce these lengths to practical values:

- The quadrupole lengths are decreased by scaling the common gradient by an arbitrary factor which results in quadrupole lengths comparable to those in the downstream section. A four-fold adjustment is made using the lengths of QF4, QF6 and QD5A,B and the drifts  $D_{2u,d}$  and  $D3$  to satisfy Eq. (1). This maneuver has *no effect on overall length*.
- With a diagonal overall transfer matrix as given in Eq. (1), the foci can be moved in a coordinated fashion as follows with *no effect on the overall 1<sup>st</sup> order transfer matrix*.

$$\Delta \ell^* (\text{downstream}) = -M^2 \Delta D_{2u} (\text{upstream}) . \quad (4)$$

With  $D_{2u}$  decreased in this way, the overall length is decreased by  $(1/M^2 - 1) \Delta \ell^*$ , where  $1/M \sim 4$  or 5. It is desirable, however, to leave  $\ell^*$  fixed and compensate  $\Delta D_{2u}$  another way. An approximate procedure is to adjust the lengths of QF1,3 and QD2A,B and QF4,6 and QD5A,B with the same result except for the appearance of non-zero matrix elements  $R_{21}$  and  $R_{43}$  in the overall transfer matrix (this deviates from the telescopic condition which was initially chosen to minimize chromatic aberrations). These matrix elements are very small ( $\sim 0.1 \text{ m}^{-1}$ ) with no significant effect on the FT performance. Similarly, simultaneous reductions of drifts  $D_{2u}$ ,  $D_{2d}$  and  $D3$  can be approximately compensated in the same fashion.

The overall length of the FT is thus reduced to an acceptable value  $L_{FT} \approx 38\text{m}$  which still leaves space for a "soft" bend magnet, corrector dipoles, instruments and other required hardware. The drift  $D3$  is chosen so that QF4,6 and QD5A,B become identical.

### The Need for Chromatic Correction

It has been found using computer simulations that the only significant aberrations in the FT are those represented by the 2<sup>nd</sup> order matrix elements  $T_{126}$  and  $T_{346}$ . In the FT these terms are both almost equal to  $L_o$  to within about 10%, or

$$T_{126} \cong T_{346} \cong L_o = \left(1 + \frac{1}{M}\right) L \quad (5)$$

where  $L$ , the length of the quarterwave section nearest to the IP, has been uniquely determined by practical constraints.

The significance of these aberrations may be evaluated in terms of an "ideal" luminosity given by

$$\mathcal{L} = \left(\frac{N^2 f}{4\pi}\right) \frac{1}{\sigma_x \sigma_y} \quad (6)$$

where  $N$  is the number of particles per pulse in each beam,  $f$  is the pulse repetition rate and  $\sigma_x \sigma_y$  is a measure of the transverse beam size at the IP.

With an unaberrated ideal beam entering the FT ( $\beta_x = \beta_y = \beta$ ,  $\alpha_x = \alpha_y = 0$  and  $\epsilon_x = \epsilon_y = \epsilon$ ) we include the effect of the aberrations in the expression  $\sigma_x \sigma_y$  by writing

$$\sigma_x \sigma_y \approx \langle x_f^2 \rangle \approx \langle y_f^2 \rangle \approx \left[ M^2 \beta + \left(1 + \frac{1}{M}\right)^2 L^2 \sigma_\delta^2 / \beta \right] \epsilon \quad (7)$$

where  $\sigma_\delta$  is the rms momentum spread of the beam. This equation as a function of  $M$  (with  $\beta$  constant) has a minimum when

$$\frac{\sqrt{1+M}}{M^2} = \frac{\beta}{L\sigma_\delta} \quad (8)$$

with a corresponding  $\beta^*$  at the IP given by

$$\beta^* = M^2 \beta = L\sigma_\delta \sqrt{1+M} . \quad (9)$$

Then, for the following optimistic parameter values:

$$\begin{aligned} \beta &= 0.12 \text{ m} , & L &= 10.7 \text{ m} , \\ N &= 5 \times 10^{10} , & f &= 180 \text{ Hz} , \\ \sigma_\delta &= 2 \times 10^{-3} , & \text{and } \epsilon &= 3 \times 10^{-3} \text{ rad-m} , \end{aligned}$$

the optimum value of  $M$  would be

$$M = 0.46 \quad \text{with} \quad \beta^* = 0.026 \text{ m} , \quad (10)$$

and the expected luminosity becomes,

$$\mathcal{L}_{\text{max}} = 2.3 \times 10^{29} \text{ cm}^{-2} \text{ - sec}^{-1} . \quad (11)$$

A design value for  $\mathcal{L}$  that is this low is unacceptable and shows the need to correct these 2<sup>nd</sup> order chromatic aberrations.

## Design of the CCS

The need to correct the unavoidable 2<sup>nd</sup> order aberrations inherent in the FT led to the introduction of the CCS. This *chromatic correction section*, just upstream of the FT is designed to introduce regions of dispersion where sextupoles can be used to cancel the overall  $T_{126}$  and  $T_{346}$  matrix elements for the combined FT and CCS.

The optical model adopted for the CCS is that of a modified *Second Order Achromat*<sup>3</sup> (SOA) consisting of four cells with an overall unit magnification. These cells are identical to each other with respect to quadrupole and sextupole components. The quadrupoles are placed to form geometrically symmetric doublets with equal strengths of opposing sign.

The two sextupoles in each cell are also identical in strength and placement to those in the other cells. This ensures that the 2<sup>nd</sup> order *geometric* aberrations from the sextupoles will be cancelled overall. In principle, only those sextupoles separated by the negative of the identity matrix (i.e., 1<sup>st</sup>-3<sup>rd</sup> and 2<sup>nd</sup>-4<sup>th</sup> cells) need be identical. The sextupoles are placed as close to the quadrupoles as practically possible to maximize their respective coupling to the  $T_{126}$  and  $T_{346}$  matrix elements and are separated by only an intervening drift to reduce sensitivity to misalignment. The strengths of the two sextupole families are now increased from the values for an SOA thus introducing aberrations in the CCS which will cancel those in the FT. Thus for an FT magnification of  $M$  it can be shown that,

$$T_{126})_{overall} = T_{126})_{FT} - M T_{126})_{CCS} = 0 \quad (12)$$

$$T_{346})_{overall} = T_{346})_{FT} - M T_{346})_{CCS} = 0 \quad (13)$$

In addition to increasing the sextupole strengths, the CCS achromat is further modified by longitudinal displacement of the dipole components. For a true SOA, there are identical bends in each cell. However, this places some bends in regions where both  $\beta$  and dispersion are large. Such placement leads to severe emittance growth caused by quantum fluctuations in the synchrotron energy loss. To mitigate this effect, all bends are located near the foci of the CCS lattice as shown in Fig. 1.

A second reason for this placement stems from the 2<sup>nd</sup> order optics: because we have now deviated from a true SOA it becomes necessary to deal with the chromatic matrix elements  $T_{166}$  and  $T_{366}$  in the CCS. It can be shown that if the dispersion is made to be identical in the first and second halves of the CCS, i.e., sequentially symmetric, these matrix elements will vanish. In the CCS the effective bend centers must coincide with the foci. Deviations of only a few centimeters will result in significant values for  $T_{166}$  and  $T_{366}$  with resulting loss of luminosity.

Suppression of emittance growth due to quantum fluctuations requires that bend strengths should be minimized. However, the sextupole strengths vary inversely with bend strength and are limited by a maximum practical value or the onset of higher order geometric aberrations. At full SLC energy, the strongest sextupoles are near the maximum practical strength. For this case loss of luminosity due to quantum fluctuations in the CCS bends alone is  $\sim 15\%$ .

### Third Order Considerations

The adopted disposition of sextupoles in the SLC CCS is the best that could be found which satisfies all of the foregoing criteria, and at the same time minimizes the dominant residual

3<sup>rd</sup> order *chromatic* aberrations,  $T_{1266}$  and  $T_{3466}$ , which limit the ultimate luminosity that can be achieved. The loss of luminosity due to these aberrations is  $\sim 20\%$  for a momentum spread of  $\sigma_\delta = 0.5$  percent. The largest residual 3<sup>rd</sup> order *geometric* aberrations  $T_{1224}$  and  $T_{3442}$  cause a corresponding loss of  $\sim 10\%$ .

The origin of the residual 3<sup>rd</sup> order *chromatic* aberrations is interesting and suggestive of a procedure to reduce them. One of us (KLB) has shown that the overall 2<sup>nd</sup> and 3<sup>rd</sup> order chromatic aberrations are related to the intrinsic aberrations of the FT and CCS as follows,

$$T_{1266})_{overall} = T_{1266})_{FT} + T_{126})_{FT} T_{226})_{CCS} + T_{116})_{FT} T_{126})_{CCS} - M T_{1266})_{CCS} \quad (14)$$

$$T_{3466})_{overall} = T_{3466})_{FT} + T_{346})_{FT} T_{446})_{CCS} + T_{336})_{FT} T_{346})_{CCS} - M T_{3466})_{CCS} \quad (15)$$

When the sextupoles are powered in a two-family configuration and adjusted so that  $T_{126})_{overall}$  and  $T_{346})_{overall}$  vanish, the 3<sup>rd</sup> order residuals,  $T_{1266})_{overall}$  and  $T_{3466})_{overall}$ , do not vanish. In fact, they are significant and limit the momentum acceptance of the system. The dominant contributions come from the 2<sup>nd</sup> order products,  $T_{126})_{FT} T_{226})_{CCS}$  and  $T_{346})_{FT} T_{446})_{CCS}$ , and not from the intrinsic 3<sup>rd</sup> order terms. This suggests that with the sextupoles powered in a four-family configuration and adjusted so that  $T_{226})_{CCS}$  and  $T_{446})_{CCS}$  as well as  $T_{126})_{overall}$  and  $T_{346})_{overall}$  vanish, the 3<sup>rd</sup> order residuals might be suppressed. Suppression factors as large as 5 have been observed in computer simulations but at the expense of excessive sextupole strengths and a significant increase of 3<sup>rd</sup> order *geometric* aberrations. So—this procedure has been of no practical value to our present design.

### Conclusions

The final design of the FFS is both practical and shown to be effective in eliminating 2<sup>nd</sup> order aberrations. Other luminosity degrading effects still remain, namely, 3<sup>rd</sup> order *chromatic* and *geometric* aberrations, emittance growth due to quantum fluctuations, and the effects of component misalignment and fabrication errors.

We believe that within the framework of our optical model a compromise has been achieved which minimizes sensitivity to these effects. For a perfect beam entering the FFS with the following parameters:  $E = 50$  GeV,  $\sigma_\delta = 5 \times 10^{-3}$ ,  $\epsilon = 3 \times 10^{-10}$  rad-m,  $f = 180$  Hz and  $N = 5 \times 10^{10}$  particles/pulse in each beam (with perfect register and no pinch) residual aberrations and quantum fluctuations contribute more or less equally and limit the luminosity to  $\sim 1 \times 10^{30}$  cm<sup>-2</sup> - sec<sup>-1</sup>. If reasonable construction tolerances are met and 1<sup>st</sup> order optical corrections are successfully applied the effect of errors could be negligible.

### References

1. *SLC Design Handbook*, December 1984.
2. *Proceedings of the SLC Workshop* SLAC-Report-247, March 1982.
3. K. L. Brown, SLAC-PUB-2257, February 1979.