

SOME FAST BEAM KICKER MAGNET SYSTEMS AT SLAC*

F. BULOS, R. L. CASSEL, A. R. DONALDSON, L. F. GENOVA, J. A. GRANT,
 A. M. MIHALKA, B. A. SUKIENNICKI, W. T. TOMLIN, F. T. VELDUIZEN, D. R. WALZ,
 J. N. WEAVER AND D. S. WILLIAMS

Stanford Linear Accelerator Center
 Stanford University, Stanford, California 94305

Abstract

The Stanford Linear Collider requires very fast rise and fall times from its kicker magnets. The damping rings and positron source need either one or two bunches deflected from two or three that are separated in time by about 59 ns. The final focus region kicker magnets need a rise time of less than 700 ns and each one deflects only one bunch. This paper discusses the design and characteristics of a thyatron-switched, castor-oil-filled, coaxial, Blumlein line used for one bunch kicking. It discharges a 118 ns (at the base), 50 kV, 3 kA pulse into a 33 cm long, ferrite-loaded, kicker magnet of rectangular coaxial-line geometry, which in turn is terminated by a matched load. Reference is made to a Fermilab (FNAL) designed magnet and a dual-thyatron pulser that will deflect two serial bunches in or out of the electron ring. Also, a brief description of the final focus magnet is given. Work is continuing on the various subsystem components to decrease the pulse rise and fall times, flattop ripple and jitter and to reduce some of the sources of noise and hv breakdown.

1. Introduction

In order to provide the required kicks to the SLC bunches at the various places noted in Figure 1, two different (a one bunch and a two bunch), very-fast systems and a fast system were developed. The positron ring kicker magnetic field, as shown in Figure 2(a), must rise and fall in less than 118 ns in order to inject or eject one bunch without disturbing the second bunch in the ring. The position source kicker deflects the last bunch (electrons) in a train of three spaced by 59 ns; so its rise time must be less than 59 ns. A one bunch, very-fast system was designed and five were built at SLAC, which incorporates four subsystems: 1) a dc charging power supply, 2) a Blumlein line pulser, 3) a kicker magnet^{1,2}, and 4) a load³.

The electron ring must have two bunches transferred in and out each cycle; thus the injection kicker pulse can rise slowly, since the ring is empty for 13 μ s before injection, but it must have a flattop of at least 59 ns, as shown in Figure 2(b) and it must fall in less than 59 ns. The same ring's ejection kicker pulse must rise in less than 59 ns, remain there for more than 59 ns and can fall slowly, since it will be 13 μ s before reinjection. The 13 μ s is the round trip time for an electron bunch to go from the electron ring to the positron source and back to the positron ring as a positron bunch. When difficulties were encountered with a modified two bunch version⁴ of the above SLAC one bunch kicker, a group at FNAL was asked to produce an alternative design and one such system was delivered in mid-1986⁵.

The final focus kicker pulses must rise in less than 700 ns and fall in less than 5.5 ms⁶. These fast kickers together with dc septums deflect the spent e^+ and e^- bunches into beam dumps after they collide at the interaction point (IP), and thus prevent their reentrance into the arcs in the reverse direction, see Figure 2(c). Currently, a second FNAL, 12.5 Ω , two bunch, kicker pulser is being built at SLAC and FNAL is building several more of the segmented-ferrite kicker magnets, a 12.5 Ω unit for the above pulser and three 16.7 Ω units for use with SLAC's Blumlein line pulsers. Thus, plenty of opportunities for mixing and matching the two systems will be possible! The SLC cycle time can be as short as 5.5 ms (180 pps) or as long as 100 ms (10 pps).

*Work supported by the Department of Energy, contract DE-AC03-76SF00515.

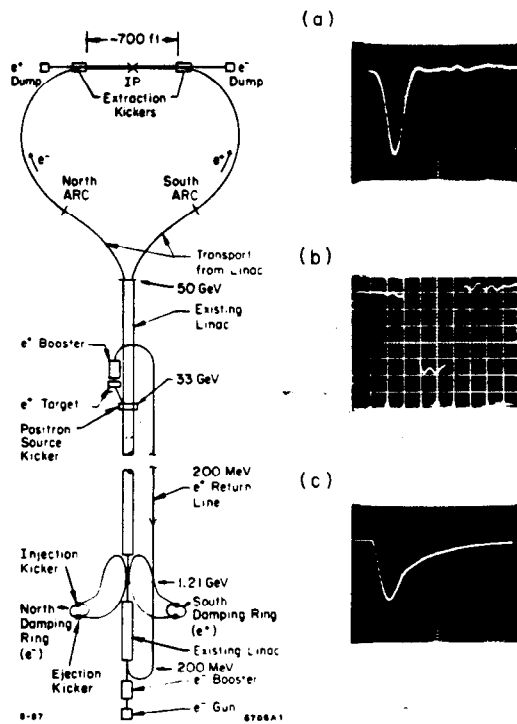

Fig. 1

Fig. 2

Figure 1. Locations and functions of the SLC fast and very-fast kicker magnets.

Figure 2(a). Pulsed magnetic field typical of the SLAC Blumlein circuit, installed in the linac positron source and in the positron damping ring. It deflects one bunch out of a series spaced by about 59 ns. AMPLITUDE SPECS.: i) positron ring - < 0.1% before and after a 118 ns pulse window; < 0.1% jitter at the mid-window pulse peak for injection and < 0.01% for ejection and ii) positron source - < 0.1% until 59 ns before the pulse peak and not critical after the pulse until the next beam cycle; < 0.1% jitter at the /ende peak. HORZ. SCALE: 50 ns/div.

Figure 2(b). Pulsed magnetic field from the FNAL pulser and its segmented-ferrite kicker magnet as installed on the electron damping ring. It deflects two bunches at a time that are separated by 59 ns. AMPLITUDE SPECS.: i) injection - not critical before the beginning of the flattop, equal within 0.1% at two points on the flattop spaced by 59 ns and < 0.1% after 59 ns after the second point on the flattop; < 0.1% jitter at the two points on the flattop ii) ejection - equal to within 0.1% at two points on the flattop spaced by 59 ns, < 0.05% until 59 ns before the first point on the flattop and not critical after the second point until the next beam cycle; < 0.01% jitter at the first point on the flattop and < 0.05% at the second point. HORZ. SCALE: 50 ns/div.

Figure 2(c). Pulsed current in the dump kicker magnet. AMPLITUDE SPECS.: < 0.015% both before 600 ns before and after 4.5 ms after the pulse peak; < 1% jitter at the pulse peak. HORZ. SCALE: 500 ns/div.

2. Design Details

The SLAC designed very-fast kicker magnet system is shown in Figure 3. Resonant charging is used with the Blumlein line voltage-doubler, which consists of a 2.7 m long, triaxial line with $Z_o = 8.4\Omega$ for both the inner and outer impedances. The total source impedance seen by the magnet is 16.7Ω . Three 50 Ω RG-220/U cables are used in parallel to interconnect the 17 Ω Blumlein line, magnet and load. Castor oil with a dielectric constant of 4.5, which is high for an oil, is used. A gear pump and heat exchanger will allow the oil to be circulated when operation at the higher repetition rates is desired. The pulse length obtained from the line is $t = 2\ell\sqrt{\epsilon}/c = 38$ ns. When the effects of the thyatron rise time, the magnet transit time and pulse distortion (mainly due to the loss and dispersion in the ferrite) are factored in, the pulse of Figure 2(a) results.

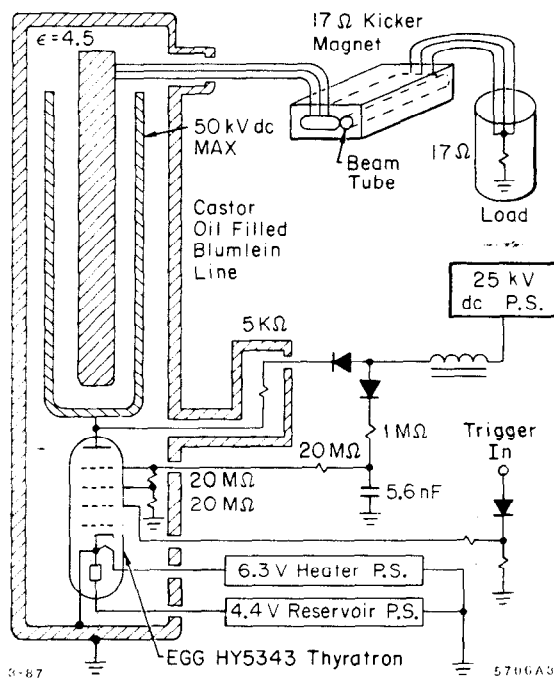

Figure 3. A simplified diagram of the SLAC, 17 Ω , Blumlein line, kicker magnet circuit.

Both the electric and magnetic fields of a kicker magnet deflect the beam. However, by design in this case, the ferrite causes the magnetic effect to dominate and the deflection angle is given by: Θ (mrad) = $0.03 \times B(G) \times \ell(m)/E$ (GeV). For the SLAC very-fast kicker magnet, B can be approximated by: $B = \mu_o \times I/(h+c/\mu)$. Furthermore, $V = I \times Z_o$, where Z_o is the characteristic impedance of the magnet. Thus, for $\Theta = 8$ mrad, $\ell = 0.33$ m, $E = 1.21$ GeV, $h = 0.023$ m, $c = 0.68$ m, $\mu = 125$ and $Z_o = 16.7\Omega$: $B = 980$ G, $I = 2.21$ kA and $V = 37$ kV. A 1.5 cm ID, 2.1 cm OD and 48 cm long alumina beam pipe passes through the magnet as shown in Figure 4. The inside of the tube is thinly coated with kovar⁷. The frequency components associated with the parasitic mode (PM) losses are much higher than those of the kicker pulse, so the tube should be transparent to the latter. A 10 Ω coating should result in about 160 W of loss ($k = 0.14V/pC$)⁸ for a 70 mA circulating beam with a damped bunch length of $\sigma_t = 20$ ns. A bellows and a ceramic disk dc block at one end of the tube increase the magnet's PM losses by about 10%. Also, there is some distortion of the magnetic field pulse due to the beam pipe [the ripple on the top of the pulse is reduced to 1/3 as much as shown in Figure 2(b), when the pipe is removed from the magnet].

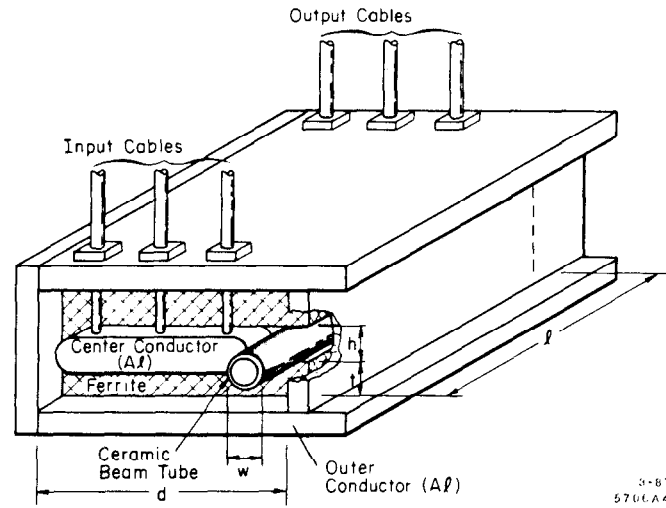

Figure 4. SLAC, 17 Ω , ferrite-loaded, matched, transmission-line, kicker magnet, where $c = 2d + h$, if $w = t$.

The matched load of Figure 5 is a modified version of a CERN design⁴. The FNAL two bunch kicker circuit of Figure 6 is shown only for comparison since it is described in detail in another paper of this conference⁵. The dump kickers use more conventional, parallel-plate magnets in a vacuum pipe, as shown in Figure 7. After the 0.05 μ F capacitors are resonantly charged, the thyatron is fired and each capacitor in turn then resonates with the inductance of its magnet. The rise time of the pulse is: $t = \pi/2\sqrt{LC} = 500$ ns. The decay time is more complicated because the HR-3 diodes de-Q the circuit through the 1.5 Ω resistors. Figure 8 shows a kicker installed in a damping ring vault.

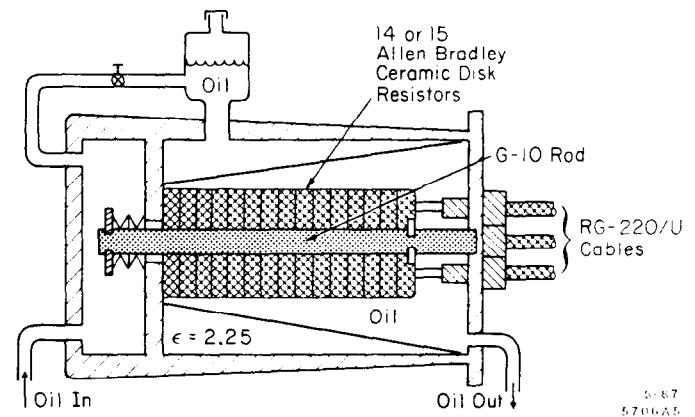

Figure 5. SLAC load for kicker magnets, shown with an oil expansion tank vented to air and a Belleville washer compressed stack of resistor rings, connected to three input cables for a 17 Ω load. One, two or four cables instead could be used with the appropriate resistor values to obtain a 50, 25 or 12.5 Ω load, if desired.

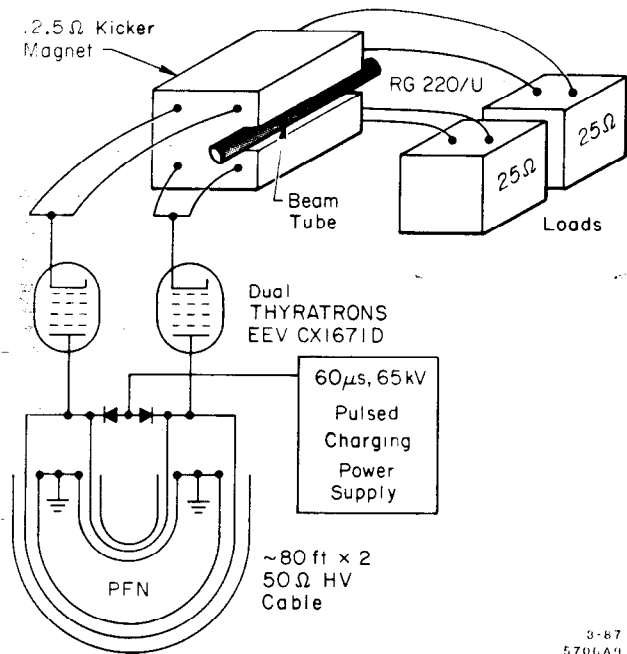

Figure 6. A simplified diagram of the FNAL, 12.5Ω, dual-thyratron, kicker magnet circuit.

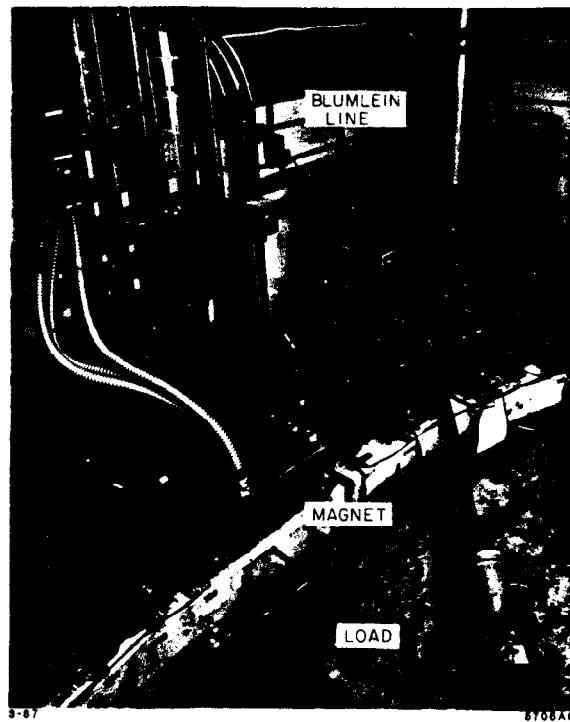

Figure 8. The Blumlein line kicker system as mounted in one of the damping ring vaults. The load is shown without its cooling circuit.

Conclusions

As seen from Figures 2(a), (b) and (c), and the specifications listed in the captions, the fast dump kicker system easily meets the requirements, but both of the very-fast kicker systems need improving. Sorting out transmission line mismatches and tracking down hv breakdown problems may help. In addition, in order to reduce the pulse distortion due to loss and dispersion in the ferrite, ways to decrease its volume and improve its high frequency response are being sought^{1,4}.

REFERENCES

1. F. Bulos, "Kicker Magnet and Pulser", SLAC CN-72, May 1981 (unpub.).
2. F. Bulos, et. al., "Damping Ring Kickers", SLAC CN-166, March 1982 (unpub.).
3. SLAC modified version of a CERN load. Refer to: D.C. Fiander, "FAK Magnet Terminating Resistors", CERN MPS/AE/NOTE 74-14, (unpub.).
4. F. Bulos et al, "Design of a Matched Fast Kicker System", SLAC-PUB-3453, Sept. 1984 (unpub.).
5. L. Bartelson et al, "Kicker for the Stanford Linear Accelerator Center Damping Ring", Particle Accelerator Conference Record 87CH2837-9, Washington, D.C., March 1987.
6. F. Bulos et al, "Beam-dump Kicker Magnets", SLAC CN-256, Dec. 1983 (unpub.).
7. R. Dixon et al, "Ultrafast Pulsed Magnets for Beam Manipulation in an Electron Storage Ring", IEEE Trans. Nucl. Sci. NS-24, 1337-9, June 1977.
8. P.B. Wilson, "Parasitic Mode Losses in the Damping Ring", SLAC CN-35, Dec. 1980 (unpub.).

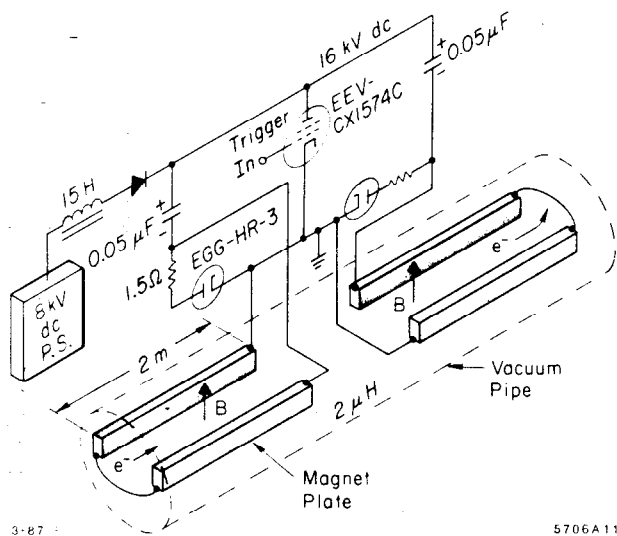

Figure 7. A simplified diagram of the SLAC, fast, dump kicker magnet circuit. For a 1.2 mrad bending angle at 50 GeV, a 2 kG·m magnet is required. This is achieved with two pairs of 2.54 cm wide by 0.3 cm thick by 2 m long copper strips spaced 2.54 cm apart in a vacuum beam pipe. With a current of 2 kA through one strip and back the other a 500 G field is generated.