

THE ANALOG PROCESSING SYSTEM FOR THE LIQUID ARGON CALORIMETER FOR SLD AT SLAC*

G. M. HALLER, D. NELSON, D. R. FREYTAG

Stanford Linear Accelerator Center, Stanford University, Stanford, California, 94305

ABSTRACT

The analog processing system for the Liquid Argon Calorimeter for the SLD project at SLAC is described. Amplification, storage of the analog information, and multiplexing is realized on specially developed hybrids, which will be mounted directly on the detector. This leads to a substantial reduction of the cable plant. Test results for the amplifier and for the sampling and multiplexing hybrid (CDU hybrid) are presented. The latter hybrid contains a custom monolithic device, the Calorimeter Data Unit (CDU).

1. INTRODUCTION

In High Energy Physics Instrumentation the trend over several decades has been towards the accumulation of more and more complete information about events of steadily increasing complexity. More recently this trend has accelerated to such an extent that even the great improvements in general purpose electronic devices do not suffice anymore, and devices need to be custom developed to satisfy the huge data handling requirements of the field.

This paper describes the analog processing system for the Liquid Argon Calorimeter (LAC) for the SLAC Linear Collider Detector (SLD)¹. The analog signals are amplified, sampled, and multiplexed in custom-made hybrids and integrated circuits mounted directly on the detector. For the required 44,000 channels for the SLD detector, this means a significant reduction in the number of analog signals which have to be routed to the outside. For this purpose three hybrids and two integrated circuits were developed. These are a sixteen-channel

protection hybrid, an eight-channel preamplifier, and a sixteen-channel sampling and multiplexing (CDU-) hybrid. The latter includes a custom integrated circuit, the Calorimeter Data Unit (CDU)². The circuits are integrated and hybridized because of space constraints on the detector and also for improved reliability. The analog data, piped optically³ out of the detector, is digitized and then corrected for offset, gain, and nonlinearity in a second specially developed integrated circuit, the Digital Correction Unit (DCU)⁴.

2. DESCRIPTION OF THE ANALOG ELECTRONICS FOR THE LAC

The outline of the electronics for the LAC is shown in Fig. 1. Protection, amplification, pulse-shaping, analog storage, and multiplexing are realized on three custom-made hybrids: a sixteen-channel protection hybrid, an eight-channel preamplifier hybrid, and a sixteen-channel CDU hybrid.

The detector elements are connected via the protection hybrid to the preamplifier hybrid. The preamplifier input has to be protected from destructive energy bursts caused by high voltage breakdown of either the tower stack or the decoupling capacitors. A maximum of 0.4 joules must be absorbed without significantly degrading the noise performance of the amplifier.

A two stage circuit is required to reduce the fault energy to safe limits. The first stage handles up to 200 amperes for several microseconds, absorbing most of the energy. Since this requires a very low ground resistance, the fairly large (80 x 80 mils) eight-ampere fast-recovery Schottky barrier diodes are assembled on a special hybrid. Each channel of the sixteen-channel protection hybrid consists of two diodes connected back-to-back, which are bonded to the substrate by 15 mil

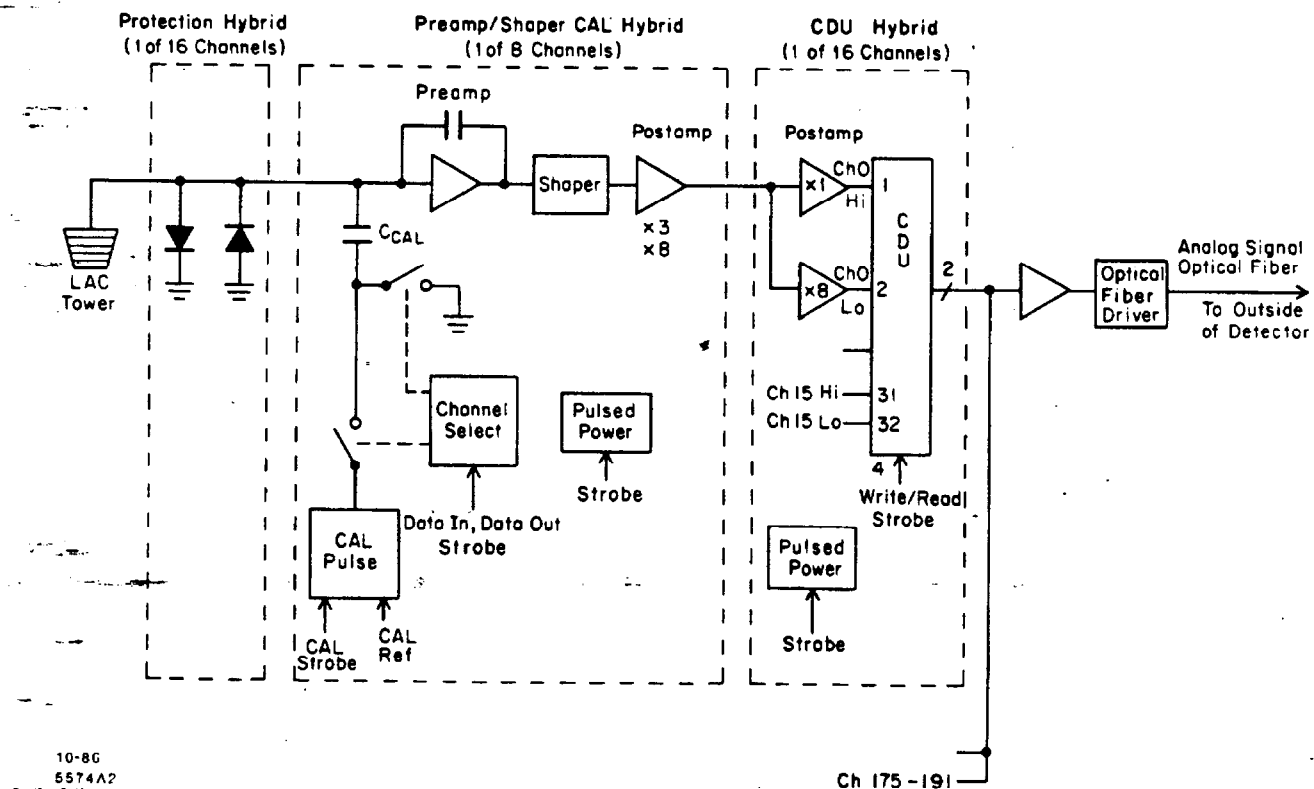

Fig. 1. Blockdiagram of the local electronics for the Liquid Argon Calorimeter.

*Work supported by the Department of Energy, contract DE-AC03-76SF00515.

wire bonds. The physical size of the hybrid is $2'' \times 0.6''$. The second protection stage reduces the remaining energy to less than 0.01 joules and is realized by a four-ohm resistor and two back-to-back high conductance signal diodes for each channel, which are placed directly on the preamplifier hybrid. Overall the protection circuit degrades the noise performance of the system by approximately 10%.

Since a liquid argon calorimeter has no gain in the sensitive medium and therefore produces very small signals, low noise amplifiers must be provided. The smallest direct signal expected is that due to a minimum ionizing particle in the first electromagnetic section, which produces 1.4×10^5 collected electrons. The largest signal, 1.2×10^8 electrons, corresponds to the charge deposited by a 50 GeV electromagnetic shower in the second calorimeter section. The signals are amplified by charge-sensitive preamplifiers with a gain of about 0.1 V/pC for the electromagnetic II, and 0.3 V/pC for the electromagnetic I and the hadronic section. Table 1 shows the tower capacitances and the electronic noise values measured for the preamplifier. Eight amplifier channels are integrated on a custom preamplifier hybrid together with circuits for shaping and post-amplification of the signals (Fig. 1). Since the primary event rate for the SLAC Linear Collider (SLC) is only 180 Hz, unipolar semi-Gaussian shaping is realized for good performance and for economical reasons. The signal-to-noise ratio is optimized for the second electromagnetic section where the intrinsic resolution is best. The optimal shaping time is 4 μ sec, determined by the average tower capacitance of 1.3 nF. Degradation of the noise performance of the other, nonoptimized sections from the optimum for their capacitance is less than $30\% \sqrt{E}$. This degradation is insignificant in the hadronic towers where the intrinsic resolution is less than $50\% \sqrt{E}$.

The high-pass first stage pulse-shaping circuit is followed by a times-eight amplifier for the first electromagnetic and the hadronic sections, or a times-three amplifier for the second electromagnetic section. As illustrated in Fig. 1 the preamplifier hybrid also includes a calibration system consisting of calibration capacitors, calibration pulse shaping, and channel select logic as well as a power switching circuit. Since the preamplifier requires 150 mW per channel (7 kW for the entire calorimeter), the power will be switched off between beam crossings to limit heating, increase reliability, and to save power. The thermal time constants are long enough that the electronics are not subject to thermal cycling stress when pulsed at 180 Hz. The preamplifier requires approximately 1 ms to stabilize, which forces a duty factor of no less than 20%. The electric energy to operate the preamplifiers in this pulsed mode is stored locally on capacitors, a technique which also reduces the required current capacity of the power supplies and cables. The preamplifier hybrid is manufactured on two separate substrates. The amplifier and the calibration section are shown in Fig. 2a and Fig. 2b, respectively. Both substrates are assembled back-to-back. The 40-pin surface-mount device measures $2'' \times 1.6''$.

The amplifier hybrid is followed by a 16-channel CDU-hybrid (Fig. 1). The device consists of post-amplifier stages for dual range operation (unity and times-eight gain to preserve the full dynamic range of the front-end electronics), final low-pass RC filters, and a custom monolithic device for storing

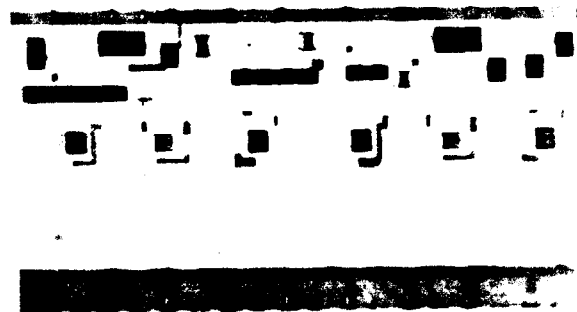
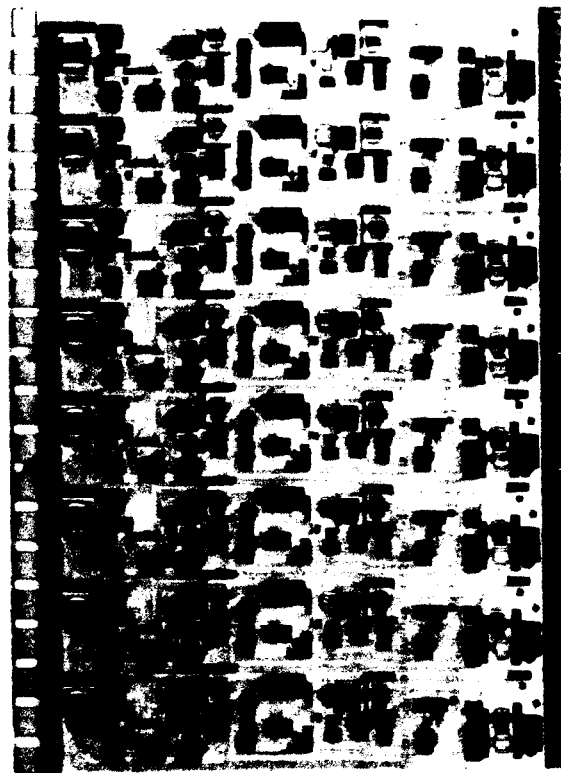

Fig. 2. Photograph of the eight-channel amplifier (Fig. 2a) and the calibration section (Fig. 2b) of the preamplifier hybrid.

and multiplexing of the analog information, the CDU². This integrated circuit is organized as 32 input channels, each consisting of four storage cells to take samples of the 32 analog signals at four separate times. For the SLD project at SLAC only two cells of each channel are used to sample the baseline

Table 1: Tower capacitances and electronic noise values.

	Tower Capacitance		Electronic Noise		Minimum Ionizing Signal (e^-)	Signal-to-Noise Ratio Minimum Ionizing	
	C_{min} (pF)	C_{max} (pF)	C_{min} (e^-)	C_{max} (e^-)		C_{min}	C_{max}
Electromagnetic							
Section 1	250	450	3000	3200	150000	50	48
Section 2	1000	1800	3900	5400	450000	117	84
Hadronic							
Section 1	3200	4900	8500	12500	300000	35	24
Section 2	4400	6300	11300	16000	300000	27	19

before beam-crossing and then the signal-peak, eliminating the baseline shift. The hybrid also contains a power pulsing circuit to minimize power consumption. Clamping transistors at the inputs of the CDU chip reduce the settling time of the coupling network during the power-up period.

The analog information stored in the CDU devices is read out serially via optical fibers to the outside of the detector. A picture of the surface-mount-CDU hybrid is shown in Fig. 3. The dimensions of the 38-pin device are 2" x 1.9".

The above described hybrids are placed on a 'daughter'-board, which processes 48 detector channels. The 7" x 5.5" board consists of three 16-channel protection hybrids, six 8-channel preamplifier hybrids, and three 16-channel CDU hybrids. Fig. 4 illustrates the organization and Fig. 5 shows a picture of the loaded 'daughter'-board. Three of the preamplifier hybrids, together with some support circuitry, are mounted on the back side of the board to optimize signal routing and to satisfy space constraints. The differential outputs of four

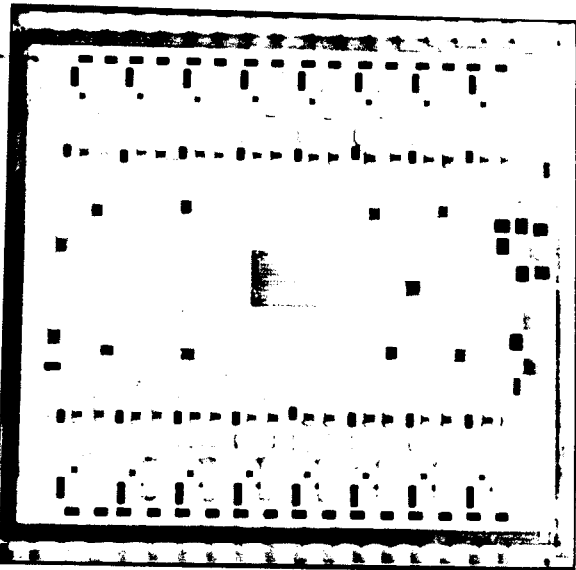

Fig. 3. Photograph of the sixteen-channel CDU hybrid.

such 'daughter'-boards, handling 192 detector channels, are bussed together and connected via a differential output stage to an optical transmitter. The analog information is then piped through an optical fiber to the outside of the detector, where digitizing, storage, and correction take place. The cable plant from the detector is therefore cut by a substantial amount through the multiplexing factor and by the ratio of the size of an optical fiber to that of a pair of wires. Furthermore the signals on optical fibers are immune to noise pick-up and ground loop currents. In a companion paper presented at this conference the analog data transmission via fiber optics is discussed³.

Since the output lines of four 'daughter'-boards are bussed together, one optical fiber carries the information of 192 detector channels or 768 storage cells (dual range, baseline and signal peak).

3-REPORT ON TESTS AND MEASUREMENTS

Figure 6 shows three modes of operation for the LAC analog processing system: write mode for calibration (Fig. 6a), write mode for signal acquisition (Fig. 6b), and read mode (Fig. 6c). In the calibration and signal acquisition modes two write strobes are provided. The first strobe samples the baselines, whereas the second records the amplified and shaped signal peaks caused by the calibration strobe or the detector signal. The baseline and peak signal level of each channel are stored on the CDU devices. The sequence of control pulses

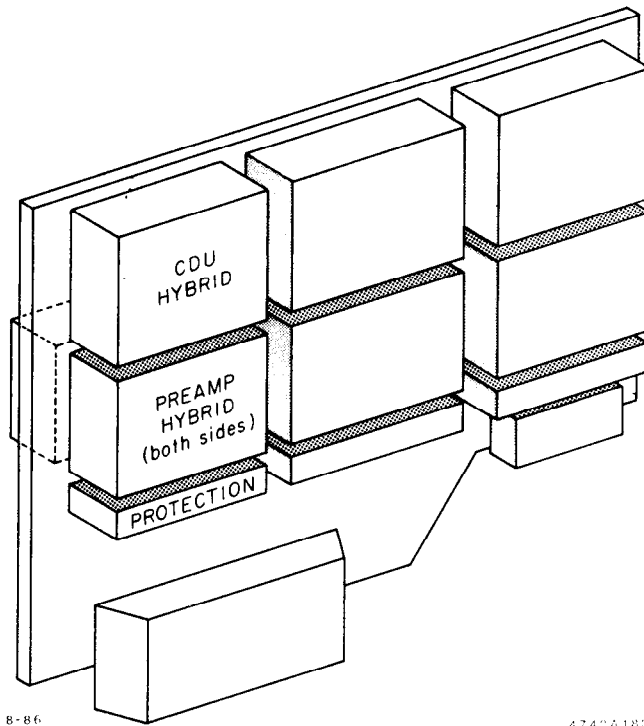

Fig. 4. Each LAC 'daughter'-board provides amplification, analog storage, and output multiplexing for 48 calorimeter towers. This board mounts directly on the liquid argon vacuum dewar.

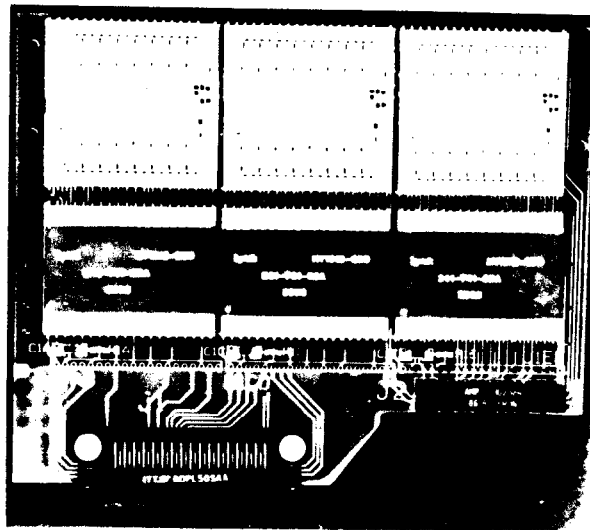

Fig. 5. Photograph of LAC 'daughter'-board serving 48 calorimeter towers.

during read-out is illustrated in Fig. 6c. All CDU devices are reset by coincident read clock 1 and read clock 2 pulses. Initiated by a START READ strobe the analog information is read out serially by a nonoverlapping two-phase clock. The 1.5 μ sec-clock is applied simultaneously to all CDU devices. Each device generates a carry-out when its last cell is selected, serving as the START READ for the next device². Figure 7 shows a typical output signal measured at the differential output driver which serves 192 detector channels. A 7 pC charge was injected by applying a 120 mV voltage step to a 60 pF

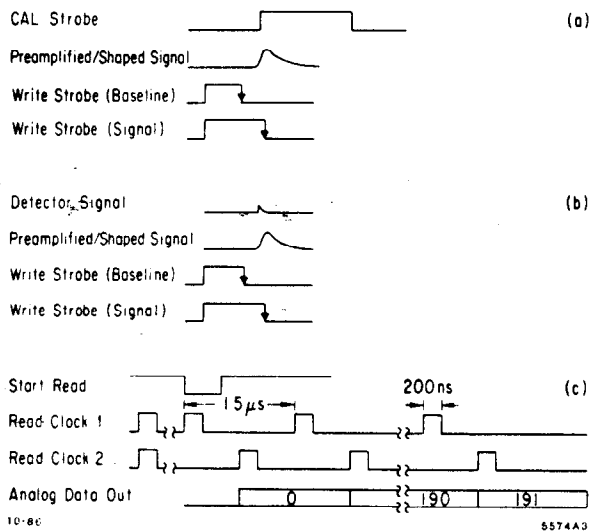
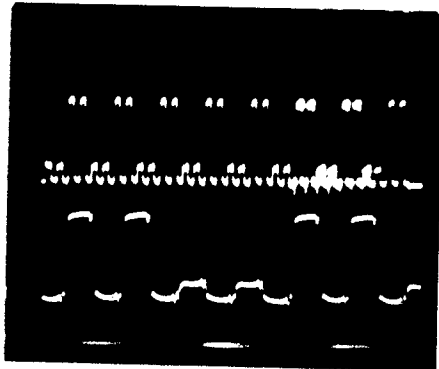

Fig. 6. Timing diagram of the most essential control signals for the LAC electronics.



10-86

5574A4

Fig. 7. Typical raw output data, repeated on an expanded time scale ($2 \mu\text{s}/\text{div}$) in the lower half of the figure. Vertical scale is $1 \text{ V}/\text{div}$. The read-out sequence is: Two signal channels at gain 1, each in the order signal and baseline. This is followed by the same channels at gain 8. The pattern is then repeated for all channels.

capacitor at the input of the preamplifier. In this test only 64 read pulse-pairs are sent to a loaded 'daughter'-board, reading out the equivalent of sixteen detector channels.

The interaction between the CDU hybrid and the preamplifier, when mounted adjacently on the 'daughter'-board, is investigated. The CDU requires strobe pulses of approximately 5 Volt amplitude coincident with the accumulation of the very small signal charge at the preamplifier input. Minimum signal charges resulting from the passage of a minimum ionizing particle are 24 fC . The maximum expected charges at the input of the preamplifier are 7 pC and 20 pC for the hadronic and the electromagnetic calorimeter, respectively. Two different versions of the preamplifier hybrid with a post-amplifier gain of three and eight give in both sections an output voltage range from 0 to 2 Volts. For the following results the 'daughter'-board was loaded with the low gain amplifiers.

The noise at the output of the CDU device (referred to the input of the preamplifier) is determined for different capacitive loads at the amplifier input. The peak value of the amplified and shaped signal at the output of the times-eight gain stage on the CDU hybrid (Fig. 1) is measured to be 0.18 V for a signal charge of 0.22 pC . This serves as a calibration for the noise measurements. The output signal read out from the CDU device is further amplified and then digitized. The equivalent noise charges at the input of the amplifier are obtained through repeated measurements and are listed in Table 2. These noise values are identical (within errors) with the results obtained for the amplifier alone (Table 1), showing no degradation for the full system.

Table 2. Equivalent noise charges at the input of the preamplifier as a function of capacitive load at the input.

Input Capacitance (nF)	RMS Noise (e^-)
0	2,500
1	3,200
2.2	4,500
4.7	12,500

At low capacitance the dynamic range is thus better than 15 bits for a channel with 20 pC full scale sensitivity.

The dynamic range of the CDU chip itself is determined by shorting the inputs of the integrated circuit to ground by the clamp transistors on the CDU hybrid. A noise voltage of 0.2 mV is measured at the input, which yields a dynamic range of more than 13 bits for the 2 Volt input range².

The cross-talk of the system is measured by applying a maximum signal and then no signal to all input channels except one. The change in a single channel is approximately 0.5% of full scale. The cross-talk measured by applying a maximum signal to a single channel while leaving the others floating is less than 0.3%.

4. SUMMARY

The analog processing of signals from the Liquid Argon Calorimeter system for the SLD detector at SLAC is described. The analog signals are amplified, sampled, and multiplexed on custom-made hybrids mounted on 'daughter'-boards directly on the detector.

Test results of a loaded 'daughter'-board with the preamplifier and the adjacently mounted CDU hybrid are presented.

Relating the measured noise charge of *e.g.*, 3200 electrons at 1 nF detector capacitance to the full scale sensitivity of the channel (20 pC), a dynamic range of better than 15 bits is determined. This signal-to-noise ratio is adequate for muon calibration and is more than adequate to provide the required energy resolution, position resolution, and pattern recognition capability.

The output voltage range is from 0 to 2 Volts. The cross-talk of the system, measured by applying a maximum signal and then no signal to all input channels except one, is $\sim 0.5\%$ of full scale. The baseline shift is eliminated by sampling before beam crossings and at signal peaks. The power consumption is 30 mW per channel for a 20% duty cycle.

Overall very good results are obtained for the performance of the system. It is shown that mounting the hybridized preamplifiers and analog storage and multiplexing circuits directly on the detector does not cause a deterioration in performance. Crosstalk and noise performance are optimized through a careful layout of the hybrids.

ACKNOWLEDGEMENTS

This project is an integral part of the SLD detector. The authors wish to acknowledge the contributions made by M. Breidenbach and R. S. Larsen in shaping this subsystem and matching it to the other parts of the apparatus. Thanks are also due to A. Gioumouisis for design and layout of the daughter board.

REFERENCES

1. SLD Design Report, SLAC-273, UC-34D (T/E/A)
2. G. M. Haller, D. R. Freytag, J. T. Walker, and S. I. Chae, "*Performance Report for Stanford/SLAC Multi-Channel Sample-and-Hold Device*", IEEE Trans. Nucl. Sci. NS-33, 221 (1986).
3. E. Cisneros, G. F. Burgueno, "*Analog Data Transmission via Fiber Optics*", these proceedings.
4. S. MacKenzie *et al.*, "*The Digital Correction Unit-A Data Correction/Compaction Chip*", these proceedings.