

LCLS LLRF UPGRADES TO THE SLAC LINAC*

R. Akre, D. Dowell, P. Emma, J. Frisch, B. Hong, K. Kotturi, P. Krejcik, J. Wu SLAC, Menlo Park, CA 94025, U.S.A. J. Byrd LBNL, Berkeley, CA, U.S.A.

Abstract

The Linac Coherent Light Source (LCLS) at SLAC will be the brightest X-ray laser in the world when it comes on line. In order to achieve the brightness a 200fs length electron bunch is passed through an undulator. To create the 200fs, 3kA bunch, a 10pS electron bunch, created from a photo cathode in an RF gun, is run off crest on the RF to set up a position to energy correlation. The bunch is then compressed by chicanes. The stability of the RF system is critical in setting up the position to energy correlation. Specifications derived from simulations require the RF system to be stable to below 200fs in several critical injector stations and the last kilometer of linac. The SLAC linac RF system is being upgraded to meet these requirements.

LCLS LLRF STATUS

Commissioning of the RF system through BC1 started in February 2007. By June 2007 all LCLS injector RF stations and the two L1 RF stations are on and operational [1]. Beam synchronous acquisition software to analyze stability has recently been completed and work to achieve the required stabilities for LCLS operation has begun.

LCLS INJECTOR-L1 RF SYSTEMS

The LCLS Injector RF system is outlined in figure 1. The LCLS Injector is off axis from the main SLAC linac and is powered from the last four klystrons in sector 20 of the main 2 mile linac. The RF Gun is powered by linac klystron station 20-6. L0 consist of two 9.5m accelerator structures powered by linac klystron stations 20-7 and 20-8. A single cell RF cavity to measure beam phase is located between L0A and L0B. The transverse accelerator, used for bunch length measurements, is powered by linac klystron station 20-5 and is located just past 20-8 in the off axis injector.

The electron beam is injected into the main linac at the beginning of Sector 21. It is then accelerated by a single S-Band station and decelerated by an X-Band station. These two RF stations are referred to as L1.

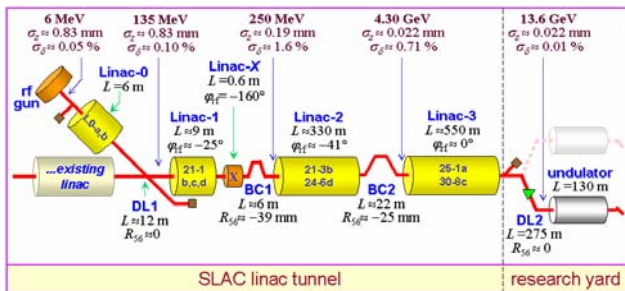

Figure 1 : LCLS Layout

After the X-Band accelerator the beam enters the chicane BC1. Linac 2, klystron stations 21-3 to 24-6, are

used to accelerate the beam to 4.3GeV before entering BC2. Linac 3, klystron stations 25-1 to 30-8, accelerates the beam to 13.6GeV.

RF Noise Specifications

The tolerances for short term (less than 2 seconds) RF stability are given in Table 1 [2]. This is often referred to as jitter and is dominated by the white noise floor in the system. The lowest noise floor is required in the X-Band system due to the bandwidth of 10 MHz.

Table 1: RF Jitter (< 2 Seconds) Specifications

ΔE/E ₀ < 0.1% and ΔI/I ₀ < 12%			
Parameter	Symbol	LCLS	Unit
Gun timing jitter	Δt ₀	0.50	psec
Initial bunch charge	ΔQ/Q ₀	2.0	%
mean L0 rf phase	φ ₀	0.10	deg
mean L1 rf phase	φ ₁	0.10	deg
mean Lh rf phase X-band	φ _h	0.50	X-deg
mean L2 rf phase	φ ₂	0.07	deg
mean L3 rf phase	φ ₃	0.15	deg
mean L0 rf voltage	ΔV ₀ /V ₀	0.10	%
mean L1 rf voltage	ΔV ₁ /V ₁	0.10	%
mean Lh rf voltage	ΔV _h /V _h	0.25	%
mean L2 rf voltage	ΔV ₂ /V ₂	0.10	%
mean L3 rf voltage	ΔV ₃ /V ₃	0.08	%

Longer term changes often referred to as drifts are dominated by electrical path length changes. The largest drifts are seen in devices with the largest electrical path lengths such as filters and long cables. Since these changes, if they can be accurately measured, can be corrected with feedbacks, the tolerances are much larger than the jitter tolerances and are given in Table 2.

Table 2: RF Drift (> 2 Seconds) Specifications

(Top 4 rows for Δσ/σ < 5%, bottom 4 limited by feedback dynamic range)		
Gun-Laser Timing	+2.4	deg-S
Bunch Charge	±3.2	%
Gun RF Phase	+2.3	deg-S
Gun Relative Voltage	+0.6	%
L0,1,X,2,3 RF Phase (approx.)	±5	deg-S
L0,1,X,2,3 RF Voltage (approx.)	±5	%

(Tolerances are peak values, not rms)

RF feedbacks will correct most of the actual errors in phase change due to temperature changes in the system. Errors in the reference system and cables which go from the monitor points to the Phase and Amplitude Detectors (PAD) are not seen by the RF system and must use beam based measurements to correct phase and amplitude of the RF system.

LLRF REFERENCE SYSTEM

The layout of the LLRF Reference system is shown in figure 2. 476 MHz is generated in Sector 0 of the linac and distributed for 3km along the linac. At Sector 20, 2km down stream a coupler picks off the 476 MHz and supplies the LCLS LLRF system. The LCLS LLRF system is in a temperature controlled RF Hut in the gallery at the end of sector 20. The room encloses a penetration down into the accelerator housing 25ft beneath the ground. The 476 MHz is multiplied by six to 2856 MHz. the 2856 MHz is divided to 25.5 MHz which is single side band modulated with the 2856 MHz to make the local oscillator frequency of 2830.5 MHz. The 2830.5 MHz is used as the local oscillator frequency, or phase reference, for the PADS.

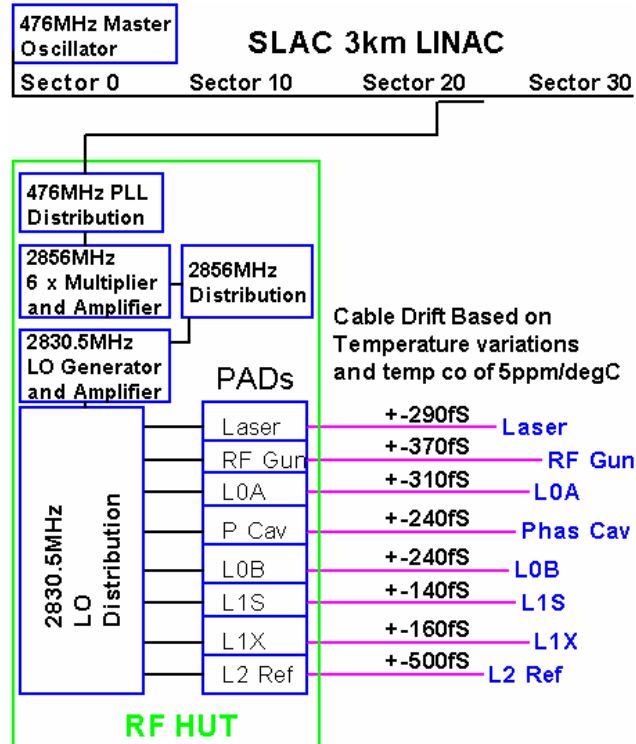

Figure 2: Reference and Signal Cables.

The cables from the RF devices to the PADS are run in temperature controlled environments. The cable used is 1/2 inch superflex and has a temperature coefficient of about 5ppm/°C. Table 3 shows the temperature requirements for different areas and the expected phase change in the cable.

Table 3: Calculated RF Cable Phase Variations

Area	$\Delta T \pm ^\circ F$	Cable Ft	Phas Error $\pm fS$
RF Hut	1.0	16	0.18
Penetration	0.1	25	0.02
Linac	0.2	12	0.02
Shield Wall	0.1	10	0.01
Injector	1.0	40	0.27
Laser Conduit	2.0	25	0.17
Laser Room	1.0	40	0.27

Phase noise measurements of the reference system in the lab were done with an Agilent E5052A Signal Source Analyzer to determine the ability of the reference system to meet the jitter requirements. Figure 3 shows the phase noise of the 476 MHz source in the lab compared to the noise level of the 476 MHz distributed in the SLAC Linac. The jitter from 10 Hz to 10 MHz is 126 fS for the linac and 20 fS for the LCLS reference oscillator. The linac RF noise levels are expected to decrease to the LCLS levels once the upgrade is complete.

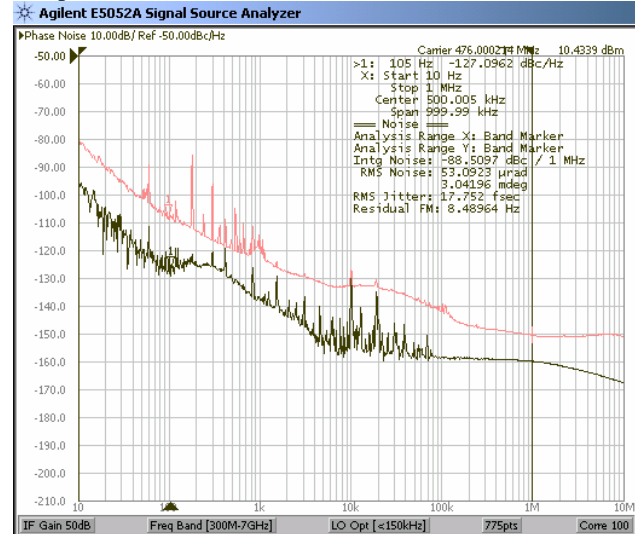

Figure 3: Phase noise spectrum of the LCLS oscillator, bottom, compared to Linac RF, Top 10 Hz to 10 MHz.

Integrated phase noise levels, jitter, of the other frequencies in the reference system compared to requirements are given in Table 4.

Table 4: RF rms jitter measurements of the reference system compared to maximum allowed values.

Frequency	Max Jitter Allowed	Measurement
476 MHz	100 fS	20 fS
2856 MHz	70 fS	22 fS
2830.5 MHz	70 fS	22 fS
102 MHz	2 pS	281 fS

At all frequencies the measured jitter is well below the maximum values, above which LCLS specifications can not be met.

The reference for the X-Band station is generated by multiplying the 2856 MHz by four to get 11.424 MHz. The same 25.5 MHz used in to generate the 2830.5 MHz LO is used to generate the LO for the X-Band system. Phase noise measurements have not yet been done for the X-Band system.

KLYSTRON RF STATION

The SLAC linac is powered by 240 60 MW SLAC klystrons. Most of the functionality of the existing

klystron stations was preserved during this upgrade. The existing system uses an "Isolator Phase Amplitude" (IPA) chassis to control the phase and amplitude of the RF for the station. The chassis is typically powered by 3 kW from a 60 kW sub-booster klystron which drives 8 klystrons in a sector. The 3 kW phase shifter is a rotary vane type driven with stepper motors. To meet the RF stability requirements for LCLS, pulse to pulse feedback is necessary, which this chassis could not handle. Due to the diagnostic capability of the old control system, this chassis remained and the new LCLS control system provides 1 kW of drive from a Solid State Sub-Booster (SSSB) to the input of the IPA Chassis. Figure 4 shows the point at which the new LCLS LLRF system ties in.

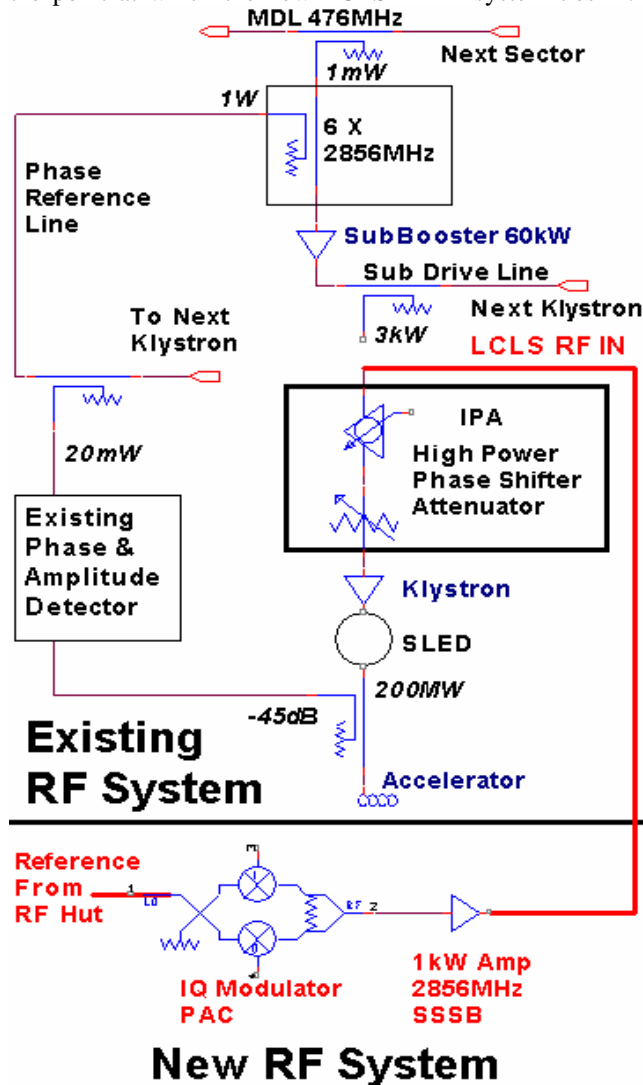

Figure 4: SLAC Linac RF System and LCLS Input.

The new system consisted of the addition of three chassis at each RF station, a Phase and Amplitude Controller (PAC), a Solid State Sub-Booster (SSSB), and a diagnostic PAD. The 2856 MHz reference, the 2830.5 MHz LO and a 102 MHz clock is distributed to each of the klystrons from the RF Hut. The 2856 MHz reference is modulated (pulse shaped) by the PAC chassis. The PAC chassis uses an IQ modulator driven by 2 high speed

16 bit DACs at 102 MHz. The PAC chassis can output any arbitrary waveform with a maximum buffer length of 2048 samples, 20 μ S. The I and Q inputs are balanced by loading I with a sine wave and Q with a cosine wave and creating a Single Side Band modulator of 49.8 kHz (102 MHz/2048 samples). The output of the PAC chassis drives the SSSB which can output up to 1 kW of power. There is about 3 dB of loss between the input of the IPA chassis and the klystron. High power SLAC klystrons that saturate at 300 W or less are selected for installation in stations driven by SSSBs.

The PAD chassis uses the 2830.5 MHz LO from the reference system to down mix the 2856 MHz RF signals to an IF of 25.5 MHz. The 25.5 MHz IF waveform is digitized with a 16 bit ADC clocked 102 MHz, four times the IF. There is a diagnostic PAD located by each of the klystron stations. All PADs which take phase critical data are located in the temperature controlled RF Hut.

EPICS BASED CONTROL SYSTEM

The LLRF controls system includes software for the three main types of controllers: the PADs, the VME IOC as a source of timing triggers and floating point processor and the PACs. The PAD and PAC modules both use an Arcturus uCdim Coldfire 5282 [3]. The realtime operating system used on both the PADs/PACs and on the VME is RTEMS [4]. The EPICS toolkit [5] runs on top of RTEMS and is useful for managing process variables. The controllers communicate via the EPICS communications protocol "Channel Access". As of June 2007, the RF system is running RTEMS 4.7.0 and epics 3.14.8.2 in production.

FUTURE TESTING

The RF feedbacks are on and running. Beam based measurements will be used to determine how stable the RF system is. The short term jitter requirements have been met for some systems, but others require further work. Long term drifts which are not measured and corrected by the RF system will be determined with the use of beam based measurements. Over the next several months there will be significant effort put into determining how the RF system performs in comparison to the specifications.

REFERENCES

- [1] P. Emma *et al.*, "Initial Commissioning Experience with the LCLS Injector" these PAC'07 proceedings, <http://www.jacow.org>.
- [2] P. Emma, "Issues and R&D Critical to the LCLS", Proceedings of the 2001 Particle Accelerator Conference, Chicago <http://accelconf.web.cern.ch/AccelConf/p01/PAPERS/TOPA008.PDF>
- [3] <http://www.arcturusnetworks.com/coldfire5282.shtml>
- [4] <http://www.rtems.com>
- [5] <http://www.aps.anl.gov/epics>

