

# DESIGN OF A FAST EXTRACTION KICKER FOR THE ACCELERATOR TEST FACILITY\*

S. De Santis<sup>#</sup>, A. Wolski<sup>†</sup>, LBNL, Berkeley, CA 94720, U.S.A.  
M.C. Ross, SLAC, Menlo Park, CA 94025, U.S.A.

## Abstract

We present a preliminary study for the design of a fast extraction kicker to be installed in the Accelerator Test Facility ring at KEK. The purpose of this project is to test the technologies to be used in the design of the extraction kickers for the International Linear Collider damping rings. The kicker's rise and fall times are important parameters in the final configuration of the rings, since they constrain the minimum distance between bunches and ultimately define a lower limit for the rings length. We investigated a stripline kicker composed of several 20-cm long sections, grouped in two different locations in the ATF damping ring. An analytical study of the kicker's parameter and computer simulations using Microwave Studio\* point out the ambitious requirements on the pulsers, in order to be able to satisfy the design specifications.

## INTRODUCTION

The injection/damping/extraction cycle in the International Linear Collider damping rings requires being able to target individual bunches for extraction without perturbing appreciably the nearby bunches. The extraction kicker performance is therefore a factor of paramount importance in the damping rings design. Depending on the kicker's rise and decay time the minimum distance between bunches will be determined, ultimately deciding the minimum length for the rings. It has been proposed to design a fast extraction kicker to be installed on the damping ring at the Accelerator Test Facility at KEK as a test bench for the technologies that will be used for the ILC design. The ATF ring and the fast kicker's relevant parameters are reported in Tab.1. In this paper we calculate analytically the kicker specifications and present the initial results of computer simulations realized using Microwave Studio.

We chose a standard stripline design for our kicker, where electric and magnetic fields of a pulse feed on the downstream termination combine to deflect transversally electrons traveling on axis. Matched load are placed on the upstream termination, in order to cancel reflected waves.

\*Work supported by the U.S. Department of Energy under Contract No. DE-AC0-05CH11231.

<sup>#</sup>[sdesantis@lbl.gov](mailto:sdesantis@lbl.gov) <sup>†</sup> Presently at Daresbury Laboratory - U.K.

Table 1: Relevant ATF parameters and fast kicker specifications.

Beam energy $E_b$	1.28 GeV
Beam pipe radius $r_p$	12 mm
Bunch spacing $t_b$	2.8 ns
Deflection angle $\theta_k$	5 mrad
Kick repetition rate $f_{rep}$	3 MHz
Total kicker length $L_T$	1.4 + 0.8 m
Kicker field at $t=t_0 + t_b$ $E(t_0 + t_b)$	$<7 \cdot 10^{-4} E(t_0)$

## ANALYTICAL CALCULATION OF THE KICKER FUNDAMENTAL PARAMETERS

Based on the specifications listed in Tab.1 we can calculate the principal kicker parameters, using the well known formulas reported, for example in [2]. First of all we want the time response of the kicker  $t_c$  to be less than the bunch spacing of 2.8 ns. Therefore from the equation

$$t_c = \frac{2\ell}{c} \quad (1)$$

we determine the maximum length of the striplines to be 20 cm.

Since there are two straight sections in the ring available for the extraction kicker long 1.4 m and 0.8 m respectively, we see that the maximum number of kicking elements is  $N_k=11$ .

We also chose to keep the distance between kicker electrodes equal to the beam pipe diameter  $r_p$ , in order to minimize the undesired effects on the circulating beam (beam coupling impedance). Naturally, the trade off of this is a higher required voltage from the pulsers. Anyway, while to some extent it is always possible to increase the voltage supplied to the striplines, corrections to the coupling impedance are usually a complicated affair. In fact, it is standard practice to use the beam pipe diameter as a first guess for the stripline distance and reduce it if the required voltage turns out to be too high.

A standard value for the stripline transverse size, which ensures a good transverse uniformity of the kick, is  $120^\circ$ . At a distance of 12 mm from the pipe axis this corresponds to a width  $w=25$  mm, so that we can estimate the stripline coverage factor from the following equation (strictly valid for parallel electrodes):

$$g = \tanh\left(\frac{\pi w}{4r_p}\right) \approx 0.93 \quad (2)$$

At this point we can calculate the voltage between electrodes required to achieve the design deflection of  $\theta_k=5$  mrad from the equation:

$$V_{\perp} = g \frac{h E_{TeV} / q_e}{2\ell} (\theta_K / N_K) \approx 37.7 \text{ kV} \quad (3)$$

where we have assumed that the betatron tune doesn't change much at the various stripline locations.

The value for  $V_{\perp}$  obtained in Eq.(3) means that the pulsers used to excite each individual stripline must generate a voltage pulse of the order of 20 kV, shorter than 1.4 ns, with a 3 MHz repetition rate. The pulser development is presently being carried out at LLNL/SLAC [3]. Depending on the maximum voltage those pulsers will achieve, we may have to reduce the distance between the kicker striplines.

The kicker shunt impedance is given by:

$$R'_s(\omega) = 2Z_c \left( \frac{2c g}{\omega h} \right)^2 \sin^2 \left( \frac{\omega}{c} \ell \right) \quad (4)$$

where  $Z_c$  is the stripline characteristic impedance, which we will design equal to 50  $\Omega$ , and is essentially the Fourier transform of the kicker impulse response. Fig.1 shows the shunt impedance function with our design parameters.

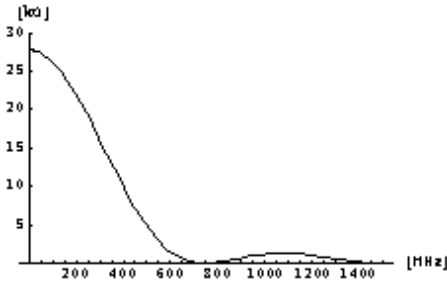

Figure1: Kicker shunt impedance.

From the shunt impedance value obtained in Eq.(4) we can calculate the maximum pulser power  $P_K$  as

$$P_K = V_p^2 / R'_s \approx 13 \text{ kW} \quad (5)$$

where  $V_p=V_{\perp}/2$  is the single stripline voltage and the average power dissipated by each kicker module:

$$P_{avg} = P_K f_{rep} 2t_c \approx 215 \text{ W} \quad (6)$$

## COMPUTER MODELLING OF THE KICKER

We used the Microwave Studio computer RF modeling code to design the kicker modules, based on the specifications obtained in the previous section.

### 2D Computer Simulations

The first step once we decided to use 120° striplines with a radius of 12 mm, is to calculate their thickness and the beam pipe radius in order to obtain a 50  $\Omega$  characteristic impedance for the *odd* TEM mode (kicking mode) that propagates in such a structure. This value is equal to the standard output impedance of RF devices and minimizes reflected waves on the pulsers, which could

damage them, and from the loads, which would increase the kicker decay time.

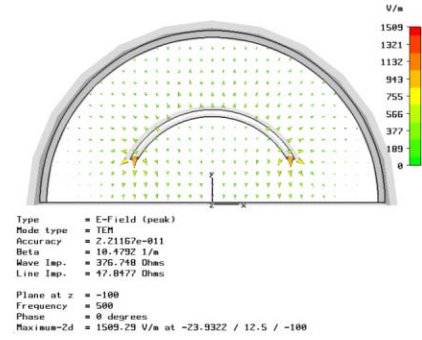

Figure 2: Microwave Studio output for the *odd* (kicking) TEM mode.

Figure 2 shows the Microwave Studio output for the *odd* TEM mode, with a stripline thickness of 0.5 mm and a beam pipe radius of 22 mm, which give characteristic impedance very close to the desired 50  $\Omega$ .

It is also standard practice to design the impedance of the *even* TEM mode equal to 50  $\Omega$ . Such a mode, where the voltage has the same phase on the two striplines, is induced by the beam itself and can perturb the circulating bunches if not properly damped.

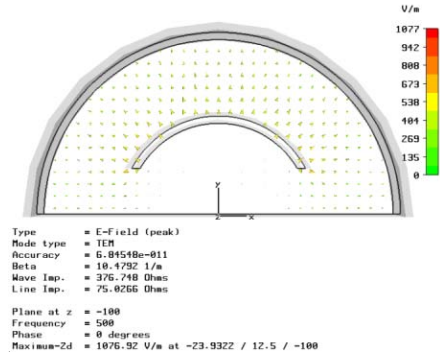

Figure 3: Microwave Studio output for the *even* TEM mode.

Figure 3 shows the computer output for the even mode. The characteristic impedance is calculated equal to 75  $\Omega$ . To bring it down to the ideal 50  $\Omega$  value we can introduce an appropriate perturbation on in the beam pipe boundary, which would leave the kicking mode unaffected, since the field transverse geometry is different for the two modes. Alternatively, one can design the matched loads to also minimize reflections from the even mode, taking advantage of the fact that the two waveform have a different frequency spectrum, since the kicking pulse has a repetition rate of 3 MHz, while the induced even mode has a repetition rate of about 357 MHz, corresponding to the bunch spacing of 2.8 ns. The frequency response of the loads can therefore be designed to be 50  $\Omega$  at one

frequency and  $357 \Omega$  at the other, although this requires specially designed loads.

### 3D Computer Simulations

At this stage we have just started the full 3D modeling of the kicker modules, which is expected to be completed by the end of September 2006.

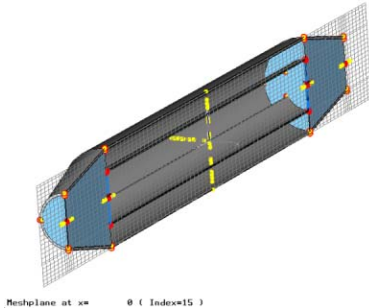

Figure 4: 3D mesh of the kicker with tapers.

We included in the design 4-to-1 tapers to connect the enlarged beampipe at the stripline location to the standard 12 mm radius beampipe, as shown in Fig.4, and we are analyzing the structure time response to different pulse shapes (Fig.5).

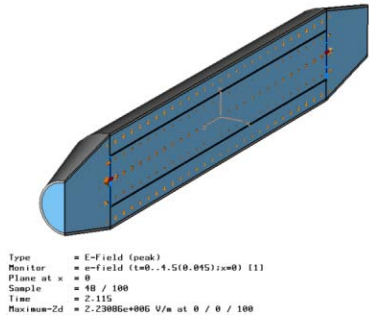

Figure 5: Example of time frame of the electric field on the kicker vertical mid-plane.

Figure 6 shows the electric field map of the kicker vertical mid-plane at the time the following bunch enters the structure after the preceding one has been kicked.

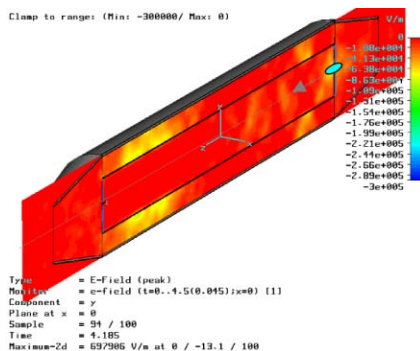

Figure 6: Electric field map at the time the trailing bunch enters the kicker structure.

From this data we can identify eventual trapped modes, should those be present. The model utilized in Figs.4-6 doesn't include the stripline feedthroughs in order to keep the processing time to a minimum.

### CONCLUSIONS

We have calculated the basic parameters for a fast extraction kicker to be installed on the Accelerator Test Facility. This kicker constitutes a test bench for the technologies that will be used for the extraction kickers in the ILC damping rings. Full 3D modeling of the stripline kicker modules is underway and is expected to be completed by the end of September 2006.

### ACKNOWLEDGEMENTS

The authors wish to thank T. Naito at KEK and A. Kransnykh at SLAC for their continuous support and advice.

### REFERENCES

- [1] <http://www.cst.com>
- [2] G. Lambertson and D. Goldberg LBNL-31664 (1992).
- [3] <http://www-project.slac.stanford.edu/ilc>