

Timing Stability and Control at the E163 Laser Acceleration Experiment*

C. McGuinness[†], E. Colby, R. Ischebeck, R. Noble, C.M.S. Sears,
R.H. Siemann, J. Spencer, D. Walz, SLAC, Menlo Park, CA, USA

T. Plettner, R.L. Byer, Stanford University, Stanford, CA 94305, USA

Abstract

The laser acceleration experiments conducted for the E163 project at the NLC Test Accelerator facility at SLAC have stringent requirements on the temporal properties of the electron and laser beams. A system has been implemented to measure the relative phase stability between the RF sent to the gun, the RF sent to the accelerator, and the laser used to generate the electrons. This system shows rms timing stability better than 1 psec. Temporal synchronicity between the 0.5 psec electron bunch, and the 0.5 psec laser pulse is also of great importance. Cherenkov radiation is used to measure the arrival time of the electron bunch with respect to the laser pulse, and the path length of the laser transport is adjusted to optimize temporal overlap. A linear stage mounted onto a voice coil is used to make shot-by-shot fine timing adjustments to the laser path. The final verification of the desired time stability and control is demonstrated by observing the peak of the laser-electron interaction signal over the course of several minutes.

INTRODUCTION

The NLC accelerator used for the E163 experiments[1] consists of an S-band photocathode gun followed by two X-band accelerator sections. A 79.333 MHz master oscillator is the source of the RF signals used in the accelerator. This signal is multiplied in two stages to produce a 2.856 GHz signal, and then multiplied additionally by 4x to produce an 11.424 GHz signal. The S-band (2.856 GHz) signal is sent to the photocathode gun, while the X-band (11.424 GHz) signal is sent to the accelerator. A portion of the original 79.333 MHz signal is also sent to a lock-to-clock unit that locks the laser master oscillator to the RF. Each of these three signals are split and a portion is sent into a phase-amplitude measurement chassis described below.

The laser master oscillator beam is split and each arm is sent through a regenerative amplifier. One of the beams is used to produce the electrons at the photocathode, while the other is sent to the experimental chamber and used to perform the laser acceleration experiments. The relative timing between the laser pulse sent to the experimental chamber and the electron bunch arriving from the accelerator can be adjusted by changing the path length of the laser transport line. A coarse timing adjustment is done using a manual linear stage guided by streak camera images of

Cherenkov radiation and laser light. The resolution of this procedure is on the order of 50 psec. Once this step is complete fine timing adjustments are done using a linear stage mounted on a voice coil while looking for an interaction signal.

PHASE STABILITY

We designed and implemented a system to measure the phase and amplitude of the RF signals. A schematic of the phase portion of this system is shown in Figure 1. The

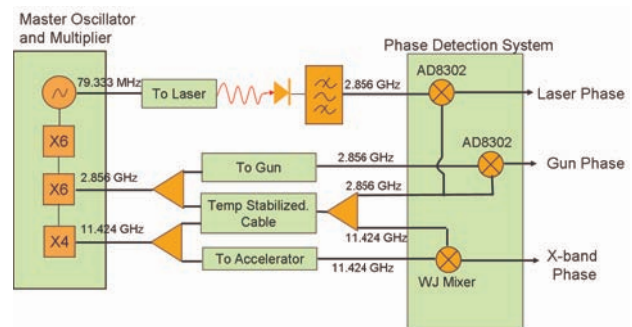

Figure 1: Schematic of the RF phase detection system implemented at the NLC Test Accelerator at SLAC.

79.333 MHz oscillator signal is multiplied in three stages yielding 2.856 GHz and 11.424 GHz signals. Each of these signals are split. One of the outputs is kept as the low level reference, and the other is amplified to high powers. The 2.856 GHz signal is sent to a klystron and then to a pulse compression system to produce 30 MW, 2.5 μ sec pulses. This high level S-band signal is sent into the electron gun. A small fraction of the signal is coupled out and sent into the phase detection system. The 11.424 GHz signal is also amplified and sent to a klystron to produce 100 MW, 200 nsec pulses, which are fed into the accelerator. A small fraction of this signal is coupled out and sent into the phase system as well. The 79.333 MHz master oscillator signal is also used to synchronize the laser to the S-band signal in the gun. A lock-to-clock box locks the phase of the mode-locked Ti:Saph laser so the 0.5 psec electron bunches produced at the photocathode ride on the proper phase of the S-band. A small fraction of the laser oscillator is picked off and measured by a fast photodiode. Many harmonics are produced by the photodiode, and a narrow band filter is used to filter all but the 2.856 GHz harmonic, which is then fed into the phase detection system.

The phase detection system is housed in a temperature

*This work is supported by Department of Energy contracts DE-AC02-76SF00515 and DE-FG06-97ER41276

[†] cmcg@slac.stanford.edu

controlled chassis mounted inside the accelerator tunnel. The S-band signal from the gun, the X-band signal from the accelerator, the laser signal from the photodiode, and the two reference signals are all fed into the chassis. An Analog Devices 8302 Evaluation board is used to measure the phase of the S-band and laser signals. This board functions as a mixer, but the output is not proportional to the amplitude of the input. This has the virtue that drifts in amplitude do not appear as drifts in phase. The X-band signals are mixed using a WJ M79 double-balanced mixer. Figure 2 shows data for a 1-2 hour period. The plots on the right are histograms of these phase values demonstrating rms phase stability better than 1 psec. The slow drift of the X-band phase is due to daily temperature drifts, and a feedback system is being developed to compensate for this effect.

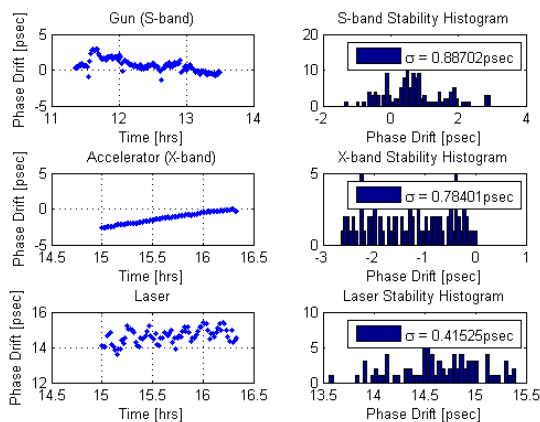

Figure 2: Phase measurement of the S-band in the gun, the X-band in the accelerator, and the laser sent to the photocathode. The y axis is phase between the reference and the signal of interest, and the x axis is time of the day in hours. The rms stability of each of the phases is shown in the histograms to the right.

TIMING CONTROL

Each of the experiments planned for E163 rely on high spatial and temporal overlap of the laser and electrons. The spatial overlap for the current set of experiments is achieved by imaging fluorescing yag screens. X and Y corrector magnets are used to steer the electrons, and motorized mirrors are used to steer the laser. Once sufficient spatial overlap is observed, the temporal overlap is addressed. This is done in two steps. The first step is a course timing adjustment, involving a streak camera and a cherenkov cell, allowing us to synchronize the laser and electron pulse to within 50 psec of each other. The second step is a fine timing adjustment, using a translation stage mounted to a voice coil. The stage is used to put random time delays in the laser beam path, effectively scanning the remaining time window for an interaction signal.

Coarse Timing Control

Prior experience from the LEAP experiments performed at the HEPL facility at Stanford University gave insight to the need for a course timing diagnostic. The electron and laser have pulse widths on the order of 0.5 psec, making it extremely difficult to find an interaction signal if the overlap is not confined to better than a few hundred picoseconds. In order to reduce the time space needed to search for the signal, we use a streak camera to simultaneously image light produced from the electrons and light from the laser directly.

Cherenkov radiation from the electron beam is used as the source of light. We pass the beam through a slice of aerogel, with an index of refraction of 1.01. This radiation is emitted at an angle given by $\cos \theta = \frac{1}{\beta n}$ [2]. For a 60MeV electrons and $n = 1.01$, this corresponds to an emission angle of 8.05° . An optical transport line was constructed to image this radiation, using UV achromatic lenses and enhanced aluminum mirrors in order to transport as much of the cherenkov light as possible. The laser was also transported along the same transport line, after being highly attenuated, and imaged with the streak camera simultaneously. An example of a typical streak is shown in Figure 3. The x-axis is time, the y-axis is position, and the intensity is denoted in color. The weak signal to the left in Figure 3(a) is the cherenkov radiation and the strong signal to the right is the laser pulse. A manual translation stage is adjusted until the overlap is optimized as shown in Figure 3(b). At this point we are confident the two beams arrive at the interaction point within less than 50 psec of each other

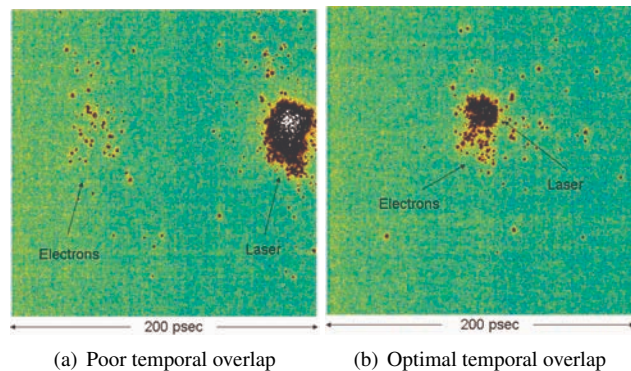

Figure 3: The path length in the laser transport line was adjusted until the faint image from the cherenkov radiation in 3(a) overlapped the clear image from the laser. The result is shown in 3(b). This allows for coarse timing overlap better 50 psec.

Fine Timing Control

The coarse timing adjustment restricts the time space needed to search down to less than 50 psec. Once this is done an automated translation stage is used to perform the fine timing adjustments. The translation stage consists

of a retroreflector mounted to a voice coil shown in Figure 4(a)¹. The stage has a range of 15 mm, allowing for path length adjustments up to 30 mm, or 100 psec. The resolution and settling time of the stage was measured using an optical encoder with an analog output. Figure 4(b) shows a plot of this measurement. The blue data is the command position, the yellow data is the response of the stage, and the red data is the response of the stage when the damping constants are optimized for the mass of the retroreflector. The accuracy was repeatably shown to be better than $25\ \mu\text{m}$ (.083 psec) with a settling time less than 75 msec for the maximum travel. These measurements demonstrate the ability to adjust the delay up to 100 psec on a shot-by-shot basis, with a temporal resolution of 0.083 psec.

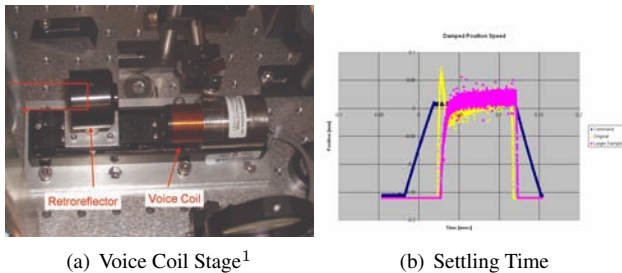

Figure 4: The voice coil controlled translation stage is used to adjust the laser transport path length at a 10 Hz rep rate, with an accuracy of $25\ \mu\text{m}$ (.083 psec), and a range of 30 mm (100 psec).

One of three methods is used to search for the laser-electron interaction. A sequential scan can be done, where the delay is sequentially increased across the entire time window. Drifts in energy spread over time lead to correlations between time and energy spread however, which can often lead to false flagging of electron-laser interactions. A second option is to generate a random number used to select the delay within the time window allotted by the coarse timing adjustment. This compensates for the time correlated energy spread, but can take quite a while to uniformly sample the entire time space. A pseudorandom number generator, following a Halton Sequence[3], is a third option that is most often used. A Halton sequence is defined for a given numerical base b . The series is computed by incrementing a variable j , in base b , reversing the digits, and putting a radix point in front of the resulting number. Computing the first six digits of the Halton Sequence for base three and converting back to base ten yields [.333 .666 .111 .444 .777 .222]. This sequence is useful for efficiently sampling a range of values in a pseudorandom fashion, and is used to efficiently sample the time space while compensating for the time energy spread correlation.

CONCLUSION

Practical issues involving the temporal overlap of electron and laser beams have been addressed and promising

¹Equipment Solutions, Sunnyvale, CA, www.equipsolutions.com

results have been demonstrated. Figure 5(a) shows data from one of the current inverse transition radiation experiments. The red data points are the events where the laser

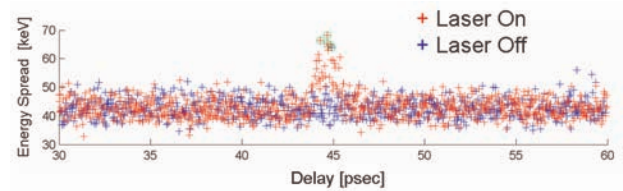

(a) Energy spread of electron beam

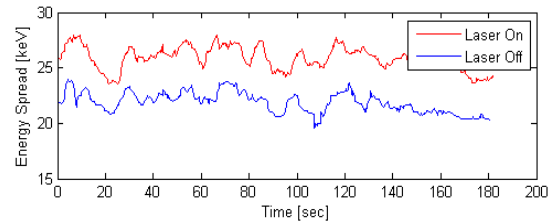

(b) Energy spread at a fixed delay time taken over the course of several minutes

Figure 5: Data from an IFEL interaction run. The energy modulation signature is clear at a 45 psec delay. The time delay was fixed at this point and data was taken for several minutes to verify the stability of the accelerator and laser systems. The fairly constant interaction signal over a three minute verifies the stability of the system.

was on, and the blue are for those where the laser was off. A clear interaction is evident by the increase in the energy spread of the beam near 45 psec. Once this signal was observed, the timing was fixed at the peak of the interaction, and data was taken over a three minute period, shown in Figure 5(b). The difference in the energy spread remains fairly constant over the three minute period, providing conclusive evidence for the stability of the beam parameters, as well as the timing control. The success of the work carried out thus far leaves us optimistic about the success of the future experiments at E163.

ACKNOWLEDGEMENTS

The authors would like to thank Janice Nelson, Doug McCormick, Justin May, Tonee Smith, and Richard Swent for all their help and time in commissioning E163 and running the experiments. Thanks also to Ron Akre for designing and engineering the master oscillator.

REFERENCES

- [1] T. Plettner, et. al. "Structure Loaded Vacuum Laser-Driven Particle Acceleration Experiments at SLAC", *12th Advanced Accelerator Concepts Workshop* **877** pp. 103 (2006).
- [2] J.D. Jackson, "Classical Electrodynamics", (1999), pg. 638.
- [3] J.H. Halton, *Numerische Mathematik* vol.2, pg. 84 (1960).