

# Study of Lattice Beams and their Limitations\*

R. Noble and J. Spencer<sup>†</sup>  
SLAC, Menlo Park, CA 94025, USA

## Abstract

Luminosity from microscale accelerators for high energy physics place a high premium on bunch repetition rate and phase space density at the interaction point (IP). The NLC Test Accelerator (NLCTA) at SLAC was built to address such beam dynamics issues. Because an S-Band, RF photoinjector has been installed together with a low-energy, high-resolving power spectrometer (LES), it is useful to explore alternatives to conventional scenarios that can be tested with minimal modifications. Interesting cases include producing simultaneous multiple bunches from the cathode in different formats such as a 2D planar matrix or 3D tensor beam made of smaller bunches or bunchlets that replace a higher charge bunch. We simulate interacting bunchlets  $n_{ij}$  or  $n_{ijk}$  coming from the cathode and passing through a solenoid that is either matched to the linac or on the LES focal plane at 5 MeV. Parmela calculations show mixed space charge and RF effects such as emittance increases for bunchlet charges summing to 50 pC.

## INTRODUCTION

Because the NLCTA[1] has a newly commissioned RF photoinjector and diagnostics section[2] it is interesting to study ways to produce exotic bunches that include bunch shaping, partition and recombination schemes. Relevance for the ILC has been discussed[3] but it also appears useful for mediating other space charge effects, experiments where a precursor bunch is needed e.g. plasma creation or for positron production schemes for a single linac collider or to improve injection rates in storage ring colliders such as BEPC[4] as well as FELs. Both RF[5] and thermionic guns[6] have been proposed for asymmetric emittances and closely spaced bunches but have space charge problems and may require sub-harmonic bunching systems and special transport. We explore how RF photoinjectors, used in novel ways, might help overcome such problems.

While the system shown in Fig. 1 was built to provide low emittance, 50 pC bunches, the NLCTA requires a variety of bunch characteristics with charges up to 1 nC. Our previous simulations[1] showed serious space charge effects for all bunch charges down to 5 pC. Beyond the usual gun and cathode diagnostics, a low energy spectrometer (LES) allows analysis and tuning of bunch energy and spread for  $\leq 7$  MeV beams with good resolution within the 1.5 m transport line between S-band cathode and X-band linac shown in Fig. 1.

\* Supported by U.S. Dept. of Energy contract DE-AC02-76SF00515.

<sup>†</sup> jus@slac.stanford.edu

## BENCHMARK DESIGNS/MODELS

Our interest and benchmark requirements began with those required for a laser acceleration experiment[7]. To keep RF induced energy spread low in the linac requires short electron bunches of order 0.1 mm for 1-2° X band. Obtaining short bunches from an S-band RF gun is straightforward at a reduced charge of 50 pC where transverse emittances are not too demanding[7]. Nevertheless, since serious space charge effects were observed for all bunch charges down to 5 pC, we take 50 pC as our total charge in any RF bucket and use a sharp cutoff, uniform distribution unless otherwise noted. Our goal is not to design specific bunch characteristics but to readily compare different ones beginning with round and flat single bunches in the system shown in Fig. 1 using the computer code Parmela[8].

**Charge Distribution Models** The system of Fig. 1, with solenoid focusing, is ideal for round beams that stay round until encountering non-axisymmetric elements. At the same time, non-axisymmetric beams require these. One can manipulate round or flat beams with well placed coupling elements such as skew quads to change shapes or exchange x-y phase space but this is not our interest. While uniform, N dimensional distributions are arguably impractical, they can be quite useful. We used a uniform, 6D, unit hyperspheroid to help design transport lines[1]. Likewise, they provide insights and limits on achievable figures of merit such as the 6D brightness when defined in Lorentz invariant ways. For linear transport in uncoupled beam lines, all 2D normalized emittances are invariant. However, for N=6, only the 4D projection remains uniform and the resulting 2D projections have peak densities that are 3 times those of uniformly filled ellipsoids i.e. projecting the bunch onto the x-y plane gives the normalized distribution:

$$\rho_n(x,y) = 3[1 - (x/x_o)^2 - (y/y_o)^2] / \pi x_o y_o \quad (1)$$

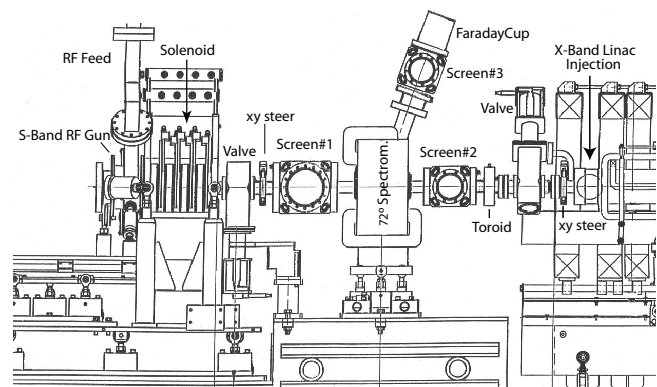

Figure 1: Layout of SLAC's NLCTA RF photoinjector line.

Because our bunches are essentially pancakes, short in the longitudinal direction, it is common to assume a uniform cylinder in  $z$  and take the transverse phase space as a uniformly filled 4D ellipsoid. This gives 2D uniformly filled ellipsoids and essentially linear space charge forces inside. Regardless of any assumed distribution  $\rho$ , one defines a bunch in terms of 6D phase space variables  $\rho(\vec{q},\vec{p},t)$  or equivalently  $\rho(x,y,z,x',y',p_z,t)$  where number density  $\delta n$  at any point in phase space  $\{\vec{q},\vec{p}\}$  is given by  $n\rho_n\delta V_6$  with overall volume  $\int dV_6$ . This hypervolume and its projections are directly related to the hyperemittances and brightnesses by various units and scaling factors depending on what is wanted e.g. geometric or normalized emittances[9]. In equilibrium,  $\rho$  does not depend on time even though individual  $\{\vec{q}_i,\vec{p}_i\}$  do so that one must integrate numerically at fixed times  $t$  or RF phase. The plots below give the  $x$ - $y$  projections at fixed RF phases but are labelled by their nominal  $z$  distances from the cathode.

Figure 2: 2D Projections in cm of a 9:1 aspect ratio bunch.

Figure 2 shows the initial projections in cm assumed at the cathode for two cases called  $n_1$  and  $n_{11}$  where the circle shows the cross section for one of the two uniform bunchlets used for  $n_{11}$  (Fig. 4) having the same cross sectional area as the single elliptical bunch  $n_1$  in Fig's. 2-3. Because we assumed a cold beam with no angular divergences, the projected areas are representative of the relative emittances with  $n_{11}$  being either twice or more than three times that of  $n_1$  depending on how one chooses to represent it. This is discussed further below in relation to Fig. 5. Finally, other than the RF cavity and solenoid in the first 40 cm or  $1400^\circ$  of S-Band phase there are no other elements since we have replaced the X-Band linac with a drift but still tuned the solenoid to produce a waist at 150 cm near its entrance as shown in Fig. 1.

**Round or Elliptical Single Bunches  $n_1$**  Figure 3 shows some of the problems encountered for single bunches  $n_1$  at two drift distances downstream of the cathode for an upright, uniform elliptical cross section bunch at the cathode having an  $x_o:y_o=9:1$  aspect ratio. From Fig. 2, the uniform laser spot on the cathode is assumed to produce a maximum, horizontal, half size of  $x_o=0.75$  cm. Phase space filamentation of the charge density is evident at both locations in Fig. 3. While these locations have similar phases  $\text{Mod}[\phi,2\pi]$ , we note that the phase itself is not important until we include the linac. Because the beam is

brought to a solenoidal focus near linac entrance at 150 cm, it follows that distortions are due to space charge and not to non-axisymmetric or nonlinear RF fields. Higher currents from thermionic cathodes may well produce different conclusions for S-Band RF. Also, rather than larger spots on the cathode to avoid space charge effects, this suggests that smaller spots or more peaked distribution or somewhat larger bunch charges and aspect ratios are possible with weaker focusing but these are subjects for further study.

Figure 3: X-Y cross sections of the 9:1 aspect ratio bunch in Fig. 2 at  $z=133$  and 300 cm before and after the focus.

**Two Round Bunchlets  $n_{11}$**  Figure 3 shows a case with two round ( $r=0.25$  cm), uniform bunches in the 1st and 3rd quadrants of the cathode centered at  $x=y=\pm 0.30$  cm with 25 pC per bunch. Thus, each point in the figure is a macro-particle carrying 0.25 pC. The idea is to study how to reduce some of the problems encountered for the single bunches in Fig. 2, without introducing new ones. In all examples, the solenoid is tuned for injection into the linac at  $\approx 150$  cm from the cathode. At 200 cm the bunches have passed through one another and are beginning to distribute back to uniformity with a much better result than for single bunches as discussed next.

Figure 4: X-Y cross sections for two bunches (25 pC each).

## DISCUSSION

In Fig. 3 a combination of RF and solenoid fields rotate and focus the beam from its initial upright shape in Fig. 2. Space charge (SC) opposes this action until it dominates without intervening optics or the linac. Unopposed there is further growth and eventual beam loss. Figure 5 shows that SC dominates near the focus to increase 2D emittance at  $z \approx 5500^\circ$  (S-Band) or 150 cm from the cathode for both cases but single bunch emittance suffers far worse being at least twice that for two bunches even though it started better by a factor of at least two. Figure 5 shows the emittances of all three single bunches as well as the emittance calculated for the two bunches of  $n_{11}$  with  $x=y=0$  as origin. The lowest curve in the rightmost figure is essentially an overlay of the two single bunch values based on using their individual mean values.

The most prominent feature is the apparent (correlated) emittance blowup and recovery through the range of the solenoid. This results from converting longitudinal into transverse phase space and peaks after the peak field of the solenoid. Figure 6 shows the invariant longitudinal emittance for explanation. The broad rounded peak just below  $1000^\circ$  is the solenoid and the sharper peaks below that are from the 1.6 cell RF cavity. Because there is no  $z$  separation between the two bunches in  $n_{11}$  the three curves overlay here although the granularity of 100 macro-particles is more apparent in this direction.

Figure 5: Invariant X emittance vs RF phase for  $n_1$  &  $n_{11}$ . Notice that the scales are very different in the two figures.

## CONCLUSIONS

We predict improved properties by partitioning the usual bunch from a single RF bucket into smaller charge bunchlets. We believe that we have seen such multi-bunchlet beams as discussed here that were unintentionally produced by the laser that appear to propagate tens of meters through the full linac, chicane, and dogleg extraction section to the spectrometer focal plane where they are distinctly resolved. Increased, variable and remotely controlled aperturing of the laser spot on the cathode together with correlation scans between the virtual image of the cathode profile and focal plane image could confirm or deny this. Also, this suggests other methods for using

the laser (low, higher order modes) or special, external profile screens to produce such beams beyond those proposed earlier[10] using an internal array to produce a matrix light profile. While many alternatives remain to be explored the apparent advantages make it very interesting to proceed both with the calculations and their tests.

## ACKNOWLEDGMENTS

We thank Steve Gierman for help with the Mathematica calculations used here. This work was supported by U.S. Dept. of Energy contract DE-AC02-76SF00515.

## REFERENCES

- [1] "Beam Dynamics Studies for a Laser Acceleration Experiment", E. Colby et al., PAC2005, May, Knoxville TN.
- [2] "Beam Dynamics Measurements for the SLAC Laser Acceleration Experiment", E. Colby et al., PAC2007, June, Albuquerque, NM. This Conference.
- [3] J.E. Spencer, "Limitations Imposed by Beam-Beam Effects and their Remedies I, II", Int'l. Jnl. Mod. Phys. A, Vol. 13(1998)2479-2492; Vol. 15(2000)2543-2554.
- [4] Shi-Lun Pei, "Studies on Two-Bunch Acceleration in Electron Linear Accelerators", SLAC Presentation, Feb. 2007.
- [5] J.B. Rosensweig, "Flat-Beam Photocathode for Linear Collider Applications", PAC1991, San Francisco, CA, May 1991.
- [6] R.T. Bhatt et al., "3D Theory and Simulation of Large-Aspect Ratio Ellipse-Shaped Charged-Particle Beam Gun", PAC2005, May, Knoxville TN.
- [7] T. Plettner, et al., "The LEAP Experiment at Stanford", PAC1999, New York, NY, May 1999. See also: T. Plettner, et al., "Visible Laser Acceleration of Relativistic Electrons in Semi-Infinite Vacuum", Phys.Rev.Lett 95,134802(2005).
- [8] H. S. Deavon, et al., LA-UR-90-1766, p. 137 (1990).
- [9] A. Chao and M. Tigner, Ed's., "Handbook of Accelerator Physics", World Publishing, Singapore, 2002.
- [10] J.E. Spencer, "The Silicon Lattice Accelerator", Int'l. Jnl. Mod. Phys. A, Vol. 18(2003)2903-2919.

Figure 6: 2D Invariant Z emittance vs phase for  $n_1$  &  $n_{11}$ .