

STATUS OF A LINAC RF UNIT DEMONSTRATION FOR THE NLC/GLC X-BAND LINEAR COLLIDER*

David Schultz, Chris Adolphsen, David Burke, Jose Chan, Steffen Doebert, Valery Dolgashev, Joe Frisch, Keith Jobe, Doug McCormick, Christopher Nantista, Janice Nelson, Marc Ross, Tonee Smith, Sami Tantawi, (SLAC, Menlo Park, California, USA), Yong Ho Chin, Sergei Kazakov, Andrei Lounine, Toshiyuki Okugi, Nobu Toge (KEK, Tsukuba, Ibaraki, Japan), Dennis Atkinson (LLNL, Livermore, California, USA)

Abstract

Designs for a future TeV scale electron-positron X-band linear collider (NLC/GLC) require main linac units which produce and deliver 450 MW of rf power at 11.424 GHz to eight 60 cm accelerator structures. The design of this rf unit includes a SLED-II pulse compression system with a gain of approximately three at a compression ratio of four, followed by an over-moded transmission and distribution system. We have designed, constructed, and operated such a system as part of the 8-Pack project at SLAC. Four 50 MW X-band klystrons, running off a common 400 kV solid-state modulator, drive a dual-moded SLED-II pulse compression system. The compressed power is delivered to structures in the NLCTA beamline. Four 60 cm accelerator structures are currently installed and powered, with four additional structures and associated high power components available for installation late in 2004. We describe the layout of our system and the various high-power components which comprise it. We also present preliminary data on the processing and initial high-power operation of this system.

THE NLC/GLC RF UNIT

Future TeV scale linear colliders have two main linacs to accelerate beams of electrons and positrons to the full center-of-mass energy.[1,2] In the design of the main linacs for the NLC/GLC X-Band linear collider this acceleration is done with ~2000 linac sub-units. Each linac sub-unit consists of a high voltage modulator powering two X-band klystrons, a SLED-II RF power pulse compression system and eight accelerator structures, as shown in figure 1.

The modulator provides a 500 kV, 500 A pulse to the two klystrons. The voltage is constant to $\pm 1\%$ over a 1.6 μs flat-top. This is accomplished using IGBT switched drivers on single turn primary cores. The primaries are summed inductively through a multi-turn secondary transformer. The use of fast 6.5 kV IGBTs makes this modulator more efficient and more easily maintainable than thyatron-switched PFN modulators.

The main linac design klystrons are 75 MW, 11.424 GHz devices. The klystron's beam is focused using a periodic permanent magnet (PPM) stack. The PPM stack

* Work supported by the U.S. Department of Energy under contract number DE-AC03-76SF00515

replaces a more conventional solenoid magnet which would use a significant amount of electrical power.

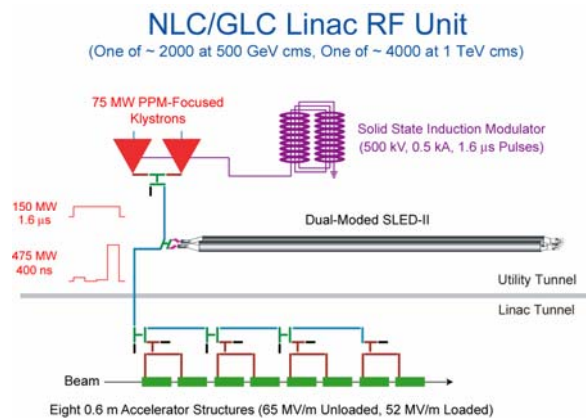

Figure 1: Schematic of the main linac RF sub-unit for the NLC/GLC.

The power from the klystrons is compressed in a second generation SLED system. The SLED-II system stores the combined power from the klystrons in a 400ns long resonant delay line. After storing the RF power in the delay lines for 1.2 μs the phase of the incoming power is flipped and the 400 ns long stored pulse is added to the last 400 ns of the incoming pulse to produce high output power. The system thus compresses the incoming RF pulse by a factor of four in time and increases the output RF power by a factor of 3.2.

Over-height and over-moded waveguide then efficiently transports this power, delivering a total of 450 MW to the accelerator structures without issues associated with excessive surface fields and breakdowns in the waveguides. The accelerator structures are capable of maintaining accelerating gradients of 65 MV/m with a breakdown rate of less than 0.1 breakdown per hour.

The full sub-unit operates at 120 Hz in the NLC and 150 Hz in the GLC.

THE '8-PACK' SYSTEM

The '8-Pack' system was originally designed to incorporate eight klystrons in a DLDS pulse compression demonstration at the Next Linear Collider Test Accelerator at SLAC. When the NLC/GLC baseline was changed to use a SLED-II pulse compression system, the

'8-Pack' system was redesigned to demonstrate the efficiency and reliability of the baseline system. The system is comprised of a 400 kV solid-state modulator powering four 50 MW X-band klystrons. The power from the four klystrons drives a dual-moded SLED-II pulse compression system.

The 8-Pack solid-state modulator was originally specified to provide power to eight 500 kV, 250A, PPM klystrons. To drive the four 50MW klystrons the modulator operates well under its original design requirements. The 1.6 μ s output high voltage pulse is held flat by delaying the turn-on of some of the IGBT driver cards. The voltage pulse is held to 400 kV \pm 0.7% over 1.6 μ s. The modulator repetition rate is 60 Hz., limited by the cooling system for the IGBTs.

As 75MW PPM klystrons were not available, the RF power is generated with four 50 MW, 11.424 GHz, solenoid-focused, X-band klystrons. The 50 MW klystrons require 300A each at 400 kV. Although they have been tested to 120 Hz, these klystrons are typically run at 60 Hz at NLCTA and elsewhere at SLAC, and have been in service for many years and have proven very reliable.

The klystron power is combined in pairs in single-moded WR90 wave guide and transported to the SLED-II pulse compression system. Here the power from the two klystron pairs is combined and manipulated in over-



Figure 2: The 8-Pack system, showing the SLED delay lines (white) attached to the copper over-height SLED head, and the high power loads above. The klystrons are in the lower right.

height, multi-moded, rectangular waveguide. The height of the waveguide was designed to keep the electric fields within the waveguide less than 50 MV/m and to keep the pulsed heating to less than 40°C.

The SLED-II 400ns long resonant delay lines are made half that length physically by storing energy in the lines in two modes [3,4]. The power from the over-height rectangular waveguide system is converted into the cylindrical TE01 mode near the entrance of the delay lines. The power propagates to the shorted end of the delay line where it is reflected and converted to the TE02 mode with an appropriately designed short. The TE02 power propagates back the entrance of the delay line where it is fully reflected in the TE02 mode. The TE02 power propagates to the shorted end of the lines where it is reflected and converted back into the TE01 mode. The TE01 power propagates to the entrance of the delay line where it is mixed with incoming TE01 power. The two round trips of the power in the dual-moded delay lines allow the lines to be approximately half the physical length of a single mode system. A detailed description of the high power system can be found in reference [5].

HIGH POWER TESTING

Following 3 weeks of high power RF processing, the SLED system reached a maximum power of 580 MW in the 400 ns output pulse. The system was then run at 500-510 MW for 200 hours at 30 Hz and 100 hours at 60 Hz to measure RF breakdown rates in the system. During the 30 Hz operation, 11 RF breakdowns were observed in the SLED system and in the over-height high power waveguide, while none were measured during the 60 Hz running. The average rate of 0.06 breakdowns per hour (60 Hz equivalent) is better than the NLC/GLC requirement of < 0.16 per hour (for 475 MW operation), and the improvement during the last 100 hours indicates the breakdown rate was decreasing.

The power in the SLED system is shown in figure 3. The relatively flat trace shows the 1.6 μ s. pulse of ~160 MW power being delivered to the SLED-II delay lines. The delivered microwave power has a 180° phase flip after 1.2 μ s, which causes a dip in the power. The other trace shows the compressed pulse coming from the SLED-II system. In addition to the ~520 MW, 400 ns. main pulse, one sees power coming from the SLED-II system at earlier times. This off-time power is inherent in SLED systems and represents the major contribution to their efficiency loss.

POWER TO STRUCTURES

Following the successful demonstration of the SLED system at full power with good reliability, the configuration was modified to deliver the power to four 60 cm accelerator structures on the NLCTA beamline. The addition of these four structures to the four structures already on the beamline transforms the NLCTA into a 360 MeV X-band accelerator.

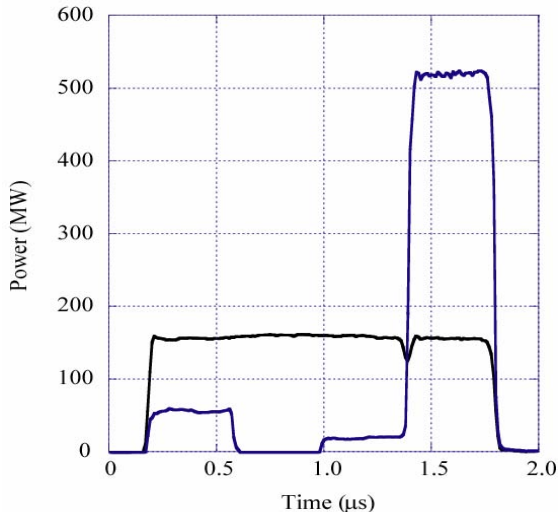

Figure 3: The power going into (flat trace) and out of (other trace) the 8-Pack SLED system

The microwave power generated by the SLED system was transmitted into the NLCTA tunnel in over-moded waveguide; in cylindrical waveguide in the TE₀₁ mode and in over-height rectangular waveguide H-bends. The power was divided near the structures in an over-height 3dB splitter. The power was then split again and directed to the structures in WR90 waveguide.

Power was delivered from the 8-Pack system to the structures on April 1st 2004. The system processed very rapidly with the structures reaching full gradient 10 days later, but as the system is only powering four accelerator structures the system upstream from the final over-height 3dB splitter is running at half of its design capacity. The RF in the four structures was then brought into phase with respect to each other by physically moving the structures up and down the beamline. Beam was then accelerated with the structures and the combined accelerator gradient verified.

The four accelerator structures powered by the 8-Pack system and the four previous structures on the NLCTA beamline have been operating at the NLC/GLC design accelerating gradient of 65 MV/m for 850 hours. During this time the 8-Pack system was up ~90% of the time. The breakdown rate, averaged over the eight structures, during the most recent 150 hours of operation, is 0.085 per hour. This rate is better than the <0.1 breakdown per hour NLC/GLC goal, and it is decreasing (the rate was 0.163 per hour after 300 hours of operation at 65 MV/m). A complete discussion of the structure testing program can be found in reference [6].

The 8-Pack system runs around-the-clock in an unattended mode. Various faults, including RF breakdown in the accelerator structures, are detected, recorded and reset by the control system. Feedback systems maintain a constant rf power. Feedback systems also maintain the tuning of the SLED resonant delay lines as the physical SLED lines change length with ambient temperature. The system can be turned off for

maintenance and restarted with little operator intervention.

FUTURE PLANS

With the high power capability and reliability of the system demonstrated, the direction of future development will be toward higher efficiency and lower costs. The power transmission of the 8-Pack project was not specifically designed to be efficient, with liberal use of the pliable but high-loss WR90 waveguide both at the klystrons and at the accelerator structures. To meet the requirements of the NLC/GLC X-Band linear collider these losses will need to be reduced.

One of the efforts toward lower cost and higher efficiency is the development of a 2-Pack modulator. The 2-Pack is a solid state modulator designed for improved reliability and manufacturability, powering two PPM klystrons. A prototype 2-Pack modulator has been built and tested to full power. It is to be installed adjacent to the NLCTA this summer and connected to two SLAC-built PPM klystrons. Power from these klystrons will be used to demonstrate the necessary power handling efficiency.

CONCLUSIONS

The 8-Pack system has been built and successfully operated. The high power capability and reliability of the system has been demonstrated during 100's of hours of operation. The system is robust, with excellent availability and little operator effort required. The system is now being used to characterize the breakdown performance of X-Band accelerator structures.

REFERENCES

- [1] "International Linear Collider Technical Review Committee, Second Report," SLAC-R-606, Feb. 2003.
- [2] C. Adolphsen et al, "International Study Group Progress Report on Linear Collider Development," SLAC-R-559, KEK-REPORT-2000-7, April 2000.
- [3] S. Tantawi, "Multimoded Reflective Delay Lines and their Application to Resonant Delay Line RF Pulse Compression Systems," Phys.Rev.ST Accel.Beams 7:032001,2004
- [4] S. Tantawi et al, "Multimoded rf delay line distribution system for the Next Linear Collider," Phys. Rev. ST Accel. Beams 3, 082001 (2000).
- [5] S. Tantawi et al, "High-Power Multimode X-Band RF Pulse Compression System for Future Linear Colliders," submitted to Physical Review STAB., also in SLAC-PUB-10520
- [6] C. Adolphsen et al, "Progress on X-band Accelerator Structure Development for NLC/GLC," EPAC'04, Lucern, July 2004, these proceedings.