

DEVELOPMENT OF A POLARIZED ELECTRON GUN BASED ON AN S-BAND PWT PHOTOINJECTOR*

D. Yu, D. Newsham, Y. Luo, A. Smirnov, *DULY Research Inc., Rancho Palos Verdes, CA 90275*
J. Clendenin, D. Schultz, *Stanford Linear Accelerator Center, Menlo Park, CA 94025*

Abstract

An RF polarized electron gun utilizing the unique features of an integrated, plane-wave-transformer (PWT) photoelectron injector [1] is being developed by DULY Research Inc. in collaboration with SLAC. Modifications to a DULY S-band device [2] include: a re-design of the photocathode/RF backplane interface to accommodate a GaAs cathode; change in the design of the vacuum ports to provide 10^{-11} Torr operation; the inclusion of a load-lock photocathode replacement system to allow for reactivation and cesiation of the GaAs photocathode in a vacuum; and alteration of the magnet field coils to make room for the load-lock. The use of a stainless steel outer tank and cooling rods without copper plating may also provide better vacuum performance at the expense of diminished Q-factor. The effectiveness of both the standard cooling rods and synthetic diamond heat sinks for disk cooling is investigated for future linear collider applications operating at a rep rate of 180 Hz and a bunch charge of 2 nC.

INTRODUCTION

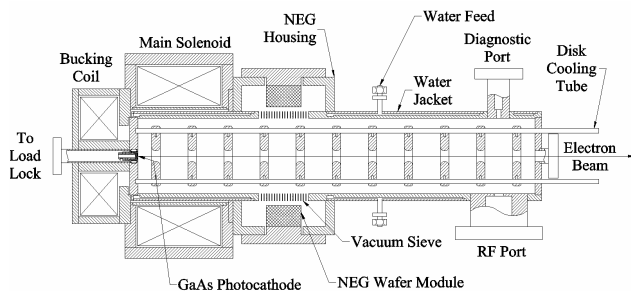

Figure 1: Schematic of the DULY S-band integrated PWT linac as modified for polarized electron production.

A polarized electron beam will be essential in future linear colliders for high-energy physics experiments to study the spin structure of fundamental particles. Important qualities required for a polarized electron source include large electron spin polarization (80%), high quantum efficiency (QE), long cathode life, high peak and average currents, and low beam emittance. An activated GaAs photocathode under extremely high vacuum can produce the required electron beam which is accelerated in an emittance-compensating rf cavity. The high vacuum conductance of the DULY S-band PWT [2], and its ability to provide excellent beam quality at low accelerating gradient make the PWT a good choice for a polarized electron gun. The new PWT design uses NEG pumps to achieve and maintain vacuum in the 10^{-11} Torr

range. Figure 1 shows a schematic of the S-band PWT as modified for use as a polarized electron gun.

VACUUM

The large vacuum conductance provided by the large annular region between the disk and the tank wall is an important feature of the PWT photoinjector. A fundamental change in the design is the incorporation of non-evaporable getter (NEG) pumps that have the unique advantage of maintaining their high pumping speed even at low vacuum pressures.

Vacuum Sieve

The S-band PWT installed at UCLA (DULY/UCLA PWT) uses a single vacuum port with a sieve consisting of 280 1/8" holes. This sieve, along with the associated piping, has a vacuum conductance that is comparable to (but less than) the conductance from the pumping port to the cathode. Two methods for increasing the effective pumping speed on the chamber exist. The first is to increase the number of identical pumping ports around the circumference of the tank, allowing for a conductance that is 3-4 times the single port value. The other option is particularly attractive if the tank is made from pure copper (not plated) and is depicted in Figure 2.

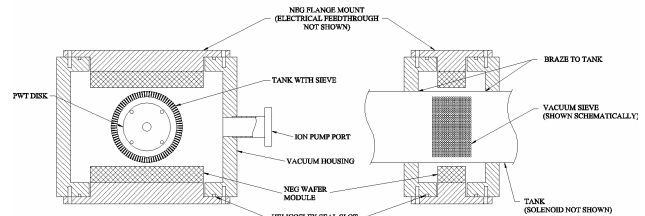

Figure 2: Schematic showing the circumferential sieve layout including the NEG modules and vacuum housing.

Instead of using several localized sieves, the holes can be drilled directly into the wall of the tank and can cover the entire circumference of the tank. This location would be surrounded by a chamber that is carefully brazed to the tank wall and contains standard NEG wafer modules capable of providing a pumping speed over 1000 l/s within the housing.

Pumping Location

The location of the pumping port can have a significant effect on the vacuum conductance from the cathode to the pumping port. The DULY/UCLA PWT has the pumping port at the 5th cell from the cathode. By moving the pumping port closer to the cathode, the vacuum conductance will increase. Table 1 shows the vacuum conductance to the photocathode of the accelerating

* Work supported by DOE SBIR grant no. DE-FG03-02ER83401.

structure based on the number of cells away from the cathode that the pumping port is located. The size of the main solenoid prevents locating the pumping port any closer than 3 cells from the cathode.

Table 1: Vacuum conductance for the DULY/UCLA PWT calculated at various cell positions.

# of cells from cathode	Vacuum Conductance (l/s)
3	94
4	71
5 (DULY/UCLA PWT)	56

Despite the increase in the vacuum conductance of the accelerating structure, with either the multiple or the full circumferential sieve option, it still limits the overall conductance of the system. In addition to compensating for the degradation in Q caused by using stainless steel, increasing the tank diameter will also improve vacuum conductance. Figure 3 shows the vacuum pressure at the cathode as the diameter of the tank is increased, assuming a fully circumferential sieve and a NEG pump speed of 1000 l/s. The different data sets correspond to location of the pumping port in terms of the number of full cells from the cathode.

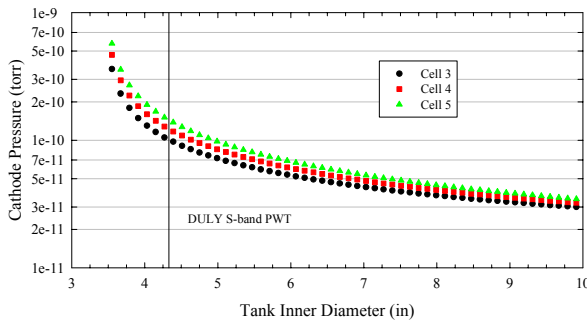

Figure 3: Pressure in the polarized PWT gun for increasing tank diameter and fully circumferential sieve.

Materials

The DULY/UCLA PWT used copper-plated 304 stainless steel for both the tank wall and the cooling/support rods. In general, clean stainless steel has an outgassing rate that is an order of magnitude lower than copper [3]. However, the increased rf losses at the tank and rods would result in an increased cooling requirement and a reduction in the Q of the structure. Thus, a higher power rf source would be required to maintain the same gradient in the $10+2\frac{1}{2}$ cell accelerating structure. Table 2 shows the Q values of a single cell without end plates when the walls and rods are made of 304 stainless steel instead of copper.

Table 2: Q-values for components made of stainless steel instead of copper, and for different tank diameters.

Stainless Steel Surface	Tank Diameter (in)			
	4.33	6.0	8.0	10.0
None	21,800	32,000	41,800	50,100
Tank wall only	8,980	14,900	21,500	27,600
Rods only	8,260	11,500	14,600	17,200
Wall and rods	5,360	8,160	11,000	13,400

The increase in Q that comes from increasing the tank diameter can compensate for the use of stainless steel walls. It is also possible to make the tank and rods from solid copper to reduce possible contamination from plating; however, the rod diameter would have to be increased to maintain strength.

CATHODE AND LOAD LOCK

An activated GaAs cathode requires a load lock system to maintain the high vacuum during the replacement or activation of the GaAs. Figure 4 shows a block diagram of the load lock system under design. In this design, the cathode puck is inserted into the vacuum system with the PWT gun isolated from the activation chamber. A magnetically coupled linear device brings the puck into the chamber through an all-metal gate valve, a wobble stick grabs the puck from the linear transporter which is then retracted, and the gate valve is closed. The wobble stick is used to lower the puck to a heater that is located inside the vacuum chamber, and is shown schematically in Figure 5. Heat cleaning of the cathode requires that the GaAs be held at 600°C for 1 hour, then rapidly cooled.

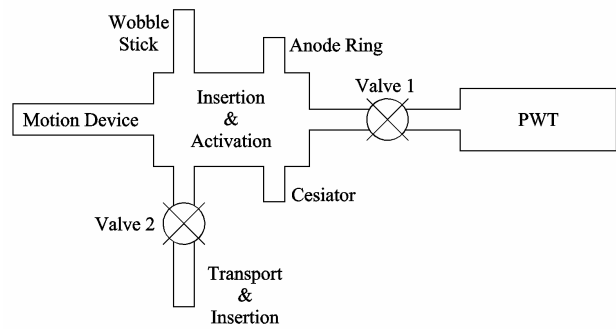

Figure 4: Block diagram of the load lock system.

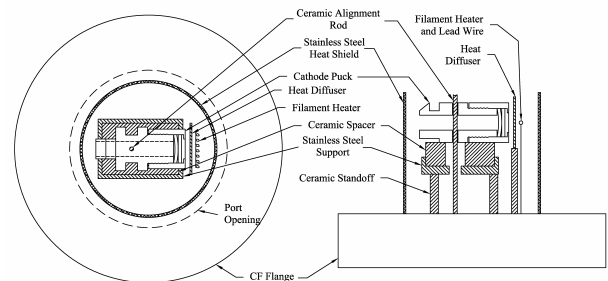

Figure 5: Schematic of the vacuum based heater used to activate the GaAs cathode.

After cleaning, the wobble stick is used to grab the cathode puck and maneuver it for mounting on the main magnetically coupled linear motion device that provides the axial transport of the puck. This linear device will place the puck in position for activation. Commercial cesium dispensers are arranged in a square pattern that will allow the puck to pass through the center. Driving current through the dispensers produces a cesium cloud that covers the surface of the GaAs. To activate the

GaAs, an oxidizing gas (O_2 or NF_3) is introduced during the cesiation process. The QE of the GaAs surface is monitored by illuminating the cathode with a laser and collecting the photoelectrons with a biased anode ring. The anode ring must be large enough for the cathode puck to pass through and is shown schematically in Figure 6.

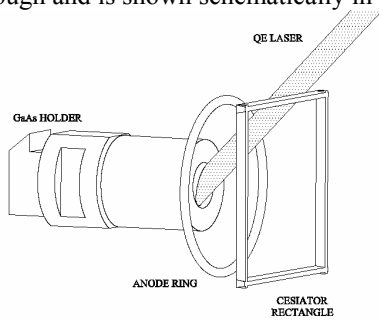

Figure 6: Schematic orientations of the anode ring, cesiator and QE diagnostic laser, showing that the laser clears the anode ring and the cesium dispensers.

After activation, the main motion device is used to move the cathode puck through a gate valve for mounting on the back plane of the PWT as shown in Figure 1. As the QE of the cathode drops, the puck is retracted back to the activation position where a new layer of cesium is deposited without the oxidizing gas.

In order to accommodate the larger size of the cathode puck, the back plane of the PWT is modified. The modifications include a larger beam pipe and flanges, as well as redesigned magnetic field coils. The rf seal at the cathode is provided by a watch-band style spring. Figure 7 shows both the axial and radial component of the magnetic field in the new solenoid design. The small radial magnetic field (Figure 7b) at the cathode of a few tens of Gauss is not expected to significantly change the longitudinal electron polarization.

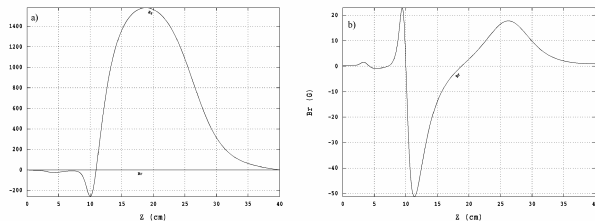

Figure 7: a) Axial and b) radial magnetic fields in the new PWT solenoid magnets. The radial field is taken near the edge of the electron beam envelope. The cathode plane is at $z = 10.92$ cm, where the axial field is null.

THERMAL SIMULATION

Steady-state thermal simulations of the S-band PWT have shown that for a 25 MW, 2.5 μs pulse width klystron operating at 10 Hz, the thermal gradient across each accelerating disk is $\sim 0.25^\circ C$, and the coldest point on the disk is $1^\circ C$ hotter than the cooling fluid. This model assumed a 1 l/s flow rate in the internal cooling channels of the PWT disk. In order to be of practical use in an advanced accelerator, the gun should operate at a higher repetition rate. Figure 8 shows the results of a finite

element analysis (COSMOS/M) of a PWT operating at 180 Hz and a field gradient of 55 MV/m for increasing values of the fluid flow rate.

An alternative design for PWT cooling could eliminate the need for rods by providing support and heat transfer with synthetic diamond [4]. Thermal simulations indicate that the performance of the water cooled structure with a flow rate of 5 l/min is equivalent to cooling with a 1 mm thick diamond heat conductor. In both models, the thermal gradient across the disk is dominated by the thermal conductivity of the copper disk, not the efficiency of cooling. Because of the cost of producing synthetic diamond, the cooling/support rod design is preferable.

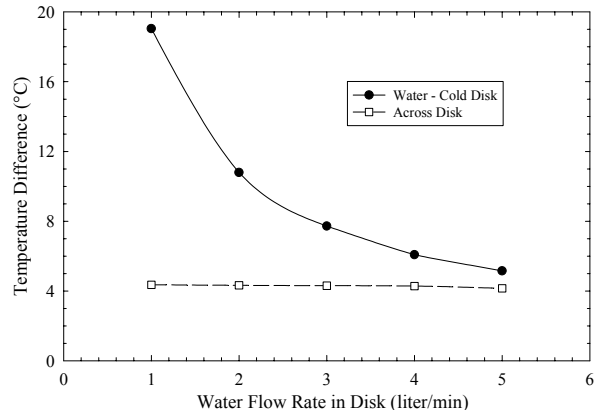

Figure 8: Temperature difference for the PWT disk as a function of flow rate. Solid line: temperature difference between the water and the coldest point on the disk; dashed line: thermal gradient across the disk.

CONCLUSION

The DULY S-band PWT integrated photoinjector has been carefully studied for use as an rf polarized electron source. The large vacuum conductance and good beam performance at low peak accelerating field make the PWT well suited for adaptation to activated GaAs use. The modifications required for the addition of a load locked activation chamber, and improved vacuum performance have been studied. Beam performance calculations, including the study of the potential problem of electron backstreaming into the cathode are discussed in a companion paper [5]. Additional advantages of operating the PWT at a low peak field (55 MV/m) are also discussed in the paper.

REFERENCES

- [1] D. Yu, J. Clendenin, R. Kirby, US patent application no. 10/261831, 9/30/02.
- [2] X. Ding *et al.*, PAC '99, p. 2021; D. Yu, in *The Physics of High Brightness Beams*, World Scientific (2000), p.585.
- [3] R.B. Neil, ed., *The Stanford Two-Mile Accelerator*, p. 889.
- [4] D.U.L. Yu, T. Lee, U.S. Patent No. 6,025,681.
- [5] Y. Luo *et al.*, WPAB042 in these proceedings.