

BEAM AMPLITUDE BEHAVIOR UPON CROSSING  
A LINEAR COUPLING RESONANCE WITH DAMPING IN ONE DIMENSION\*

SLAC-PUB-549  
AADD-152  
February 1969  
(ACC)

M. J. Lee, E. D. Courant,  
Brookhaven National Laboratory  
Upton, New York

C. Pellegrini,  
Laboratori Nazionali di Frascati  
Frascati, Rome, Italy

A. M. Sessler  
Lawrence Radiation Laboratory  
Berkeley, California

Introduction

A small coupling perturbation in a synchrotron can cause instability of the particle motions as a beam is being accelerated through a resonance.<sup>1</sup> Such a resonance may occur whenever  $n_1\nu_1 + n_2\nu_2 = n_3$ , where  $n_1$ ,  $n_2$  and  $n_3$  are integers and  $\nu_1$  and  $\nu_2$  are the ratios of the frequencies of horizontal and vertical betatron oscillations to the frequency of revolution. Recently, large growth of beam dimensions in the horizontal direction relative to the vertical direction has been observed<sup>2</sup> in the ZGS for some acceleration routes in which several resonances were crossed. The experimental observation suggests that the damper used for the vertical beam instability may be responsible for this effect.

A study has been conducted to investigate theoretically the effects of vertical damping on the betatron oscillations for particles passing through a resonance. This report describes a calculation for a single-particle model and for the case of the  $\nu_1 + \nu_2 = 1$  resonance.

Theory

The coordinates of the system are taken to be:

$x(z)$  = horizontal (vertical) displacement from the equilibrium orbit;

$P_x(P_z)$  = canonically conjugate momentum of  $x(z)$ .

The equilibrium orbit is assumed to be in a horizontal plane and the independent variable is chosen to be

$$\theta = \frac{s}{R},$$

where  $R$  is the average radius of the equilibrium orbit and  $s$  is the particle position measured along the equilibrium orbit.

In general, the Hamiltonian is of the form<sup>1</sup>

$$\mathcal{H}(x, P_x, z, P_z, \theta) = \frac{1}{2}(\nu_1^2 x^2 + P_x^2) + \frac{1}{2}(\nu_2^2 z^2 + P_z^2) + \sum_{n=2} \epsilon_n \mathcal{H}_n, \quad (1)$$

\*Work supported by the U.S. Atomic Energy Commission.

where  $\epsilon_n$  is a coupling constant and  $\mathcal{H}_n$  is a polynomial of  $n$ th degree in the variables  $(x, P_x, z, P_z)$  with coefficients which are functions of  $\theta$ .

In this analysis, we treat the case of quadrupole coupling so that

$$\begin{aligned} \mathcal{H}_n &= 0, \quad n \neq 2; \\ \mathcal{H}_2(x, z, \theta) &= \nu_1 \nu_2 xz \cos \theta. \end{aligned} \quad (2)$$

The value of  $\nu_1$  is taken to be a constant,  $\nu_2$  is assumed to be a function of  $\theta$ . As  $\theta$  increases from zero to its maximum value  $\theta_{\max}$ , the resonance condition is satisfied for  $\theta = \theta_0$ , i.e.,

$$\nu_1 + \nu_2(\theta_0) = 1. \quad (3)$$

Consider a generating function

$$\begin{aligned} S_1(x, \phi_1, z, \phi_2, \theta) &= \frac{1}{2} \nu_1 x^2 \tan [\phi_1 + X_1(\theta)] \\ &+ \frac{1}{2} \nu_2 z^2 \tan [\phi_2 + X_2(\theta)] \end{aligned} \quad (4)$$

which effects the transformation between the sets of variables  $(x, P_x, z, P_z)$  and  $(J_1, \phi_1, J_2, \phi_2)$ . If we choose  $X_1(\theta) = -\nu_1$  and  $X_2(\theta) = -\nu_2$  then the transformed Hamiltonian is of the form:

$$\begin{aligned} G_1(J_1, \phi_1, J_2, \phi_2, \theta) &= \\ &= 2\epsilon \sqrt{\nu_1 \nu_2 J_1 J_2} \cos(\phi_1 + X_1) \cos(\phi_2 + X_2) \cos \theta \\ &+ \frac{\dot{\nu}_2}{\nu_2} J_2 \cos(\phi_2 + X_2) \sin(\phi_2 + X_2). \end{aligned} \quad (5)$$

A second generating function

$$S_2(J_1, \psi_1, J_2, \psi_2, \theta) = J_1(\psi_1 - X_1) + J_2(\psi_2 - X_2) \quad (6)$$

transforms  $G_1$  into the form

$$\begin{aligned} G_2(J_1, \psi_1, J_2, \psi_2, \theta) &= 2\epsilon \sqrt{\nu_1 \nu_2 J_1 J_2} \cos \psi_1 \cos \psi_2 \cos \theta \\ &+ \frac{\dot{\nu}_2}{\nu_2} J_2 \cos \psi_2 \sin \psi_2 + \nu_1 J_1 + \nu_2 J_2 \end{aligned} \quad (7)$$

with the new variables defined by

$$\begin{aligned} J_1 &= \frac{1}{2\nu_1} \left( \nu_1^2 x^2 + P_x^2 \right), & \psi_1 &= \tan^{-1} \frac{P_x}{\nu_1 x}, \\ J_2 &= \frac{1}{2\nu_2} \left( \nu_2^2 z^2 + P_z^2 \right), & \psi_2 &= \tan^{-1} \frac{P_z}{\nu_2 z}. \end{aligned} \quad (8)$$

The equations of motion, as in all Hamiltonian systems, are:

$$\begin{aligned} \frac{dJ_1}{d\theta} &= \frac{\partial G_2}{\partial \psi_1}, & \frac{d\psi_1}{d\theta} &= -\frac{\partial G_2}{\partial J_1}, \\ \frac{dJ_2}{d\theta} &= \frac{\partial G_2}{\partial \psi_2}, & \frac{d\psi_2}{d\theta} &= -\frac{\partial G_2}{\partial J_2}. \end{aligned} \quad (9)$$

We now suggest that the effect of the damper used for the vertical beam instability may be described by adding a term proportional to  $\dot{z}$  in the equation of motion for the vertical direction, i.e., we consider a model in which:

$$\begin{aligned} \frac{dP_z}{d\theta} &= -\frac{\partial \mathcal{H}}{\partial z} - \beta \dot{z}, \\ &= -\nu_2^2 z - \epsilon \nu_1 \nu_2 x \cos \theta - \beta \dot{z}, \end{aligned} \quad (10)$$

where  $\beta$  is a damping constant. Since

$$\frac{dJ_2}{d\theta} = \frac{\partial J_2}{\partial z} \dot{z} + \frac{\partial J_2}{\partial P_z} \dot{P}_z$$

and a similar relation holds for  $\psi_2$ , we deduce that to first order in  $\beta$  the corresponding changes in the equations of motion are given by:

$$\frac{dJ_2}{d\theta} = \frac{\partial G_2}{\partial \psi_2} - \beta \dot{z} \frac{\partial J_2}{\partial P_z} \quad (11)$$

and

$$\frac{d\psi_2}{d\theta} = -\frac{\partial G_2}{\partial J_2} - \beta \dot{z} \frac{\partial \psi_2}{\partial P_z} \quad (12)$$

Combining Eqs. (7), (9), (11) and (12), the equations of motion for particles crossing a sum resonance in the presence of vertical damping are found to be:

$$\begin{aligned} \frac{dJ_1}{d\theta} &= -2\epsilon \sqrt{\nu_1 \nu_2 J_1 J_2} \cos \theta \sin \psi_1 \cos \psi_2 \\ \frac{dJ_2}{d\theta} &= -2\epsilon \sqrt{\nu_1 \nu_2 J_1 J_2} \cos \theta \cos \psi_1 \sin \psi_2 \\ &\quad + \frac{\dot{z}}{\nu_2} J_2 \left( \cos^2 \psi_2 - \sin^2 \psi_2 \right) - 2\beta J_2 \sin^2 \psi_2 \end{aligned}$$

$$\begin{aligned} \frac{d\psi_1}{d\theta} &= -\epsilon \sqrt{\frac{\nu_1 \nu_2 J_2}{J_1}} \cos \theta \cos \psi_1 \cos \psi_2 - \nu_1 \\ \frac{d\psi_2}{d\theta} &= -\epsilon \sqrt{\frac{\nu_1 \nu_2 J_1}{J_2}} \cos \theta \cos \psi_1 \cos \psi_2 - \nu_2 \\ &\quad - \left( \frac{\dot{z}}{\nu_2} + \beta \right) \cos \psi_2 \sin \psi_2. \end{aligned} \quad (13)$$

### Numerical Calculation and Results

The effect of vertical damping upon the betatron oscillations for particles passing through a  $\nu_1 + \nu_2 = 1$  coupling resonance has been studied by integrating, stepwise,<sup>3</sup> Eqs. (13). In the calculation, we assume  $\nu_1 = 0.3$ ,  $\nu_2$  varies linearly from 0.6 to 0.8 in one hundred revolutions, and  $\epsilon = 0.04$ . The growths of  $J_1$  and  $J_2$  are calculated as functions of  $\theta$  for various values of  $\beta$ . Figure 1 shows the values of  $J_1$  after 25, 50, 68 and 100 revolutions for particles having initial values of  $J_1$ ,  $J_2$ ,  $\psi_1$  and  $\psi_2$  as represented in Fig. 2. It has been found that, in general, for particles having  $J_1(0) < J_{1\max}(0)$ , then  $J_1(\theta) < J_{1\max}(\theta)$  so that the horizontal growth of the beam may be characterized by the values of  $J_{1\max}$ . Similar results are obtained for  $J_2$ , as indicated in Figs. 3 and 4.

To illustrate the growth of the beam, the values of  $J_{1\max}$  and  $J_{2\max}$  as functions of  $\nu_2(\theta)$  are plotted in Fig. 5 for the case of  $\beta = 0.004$ . At resonance,  $\nu_2 = 0.7$ . It may be seen that except in the neighborhood of resonance,  $J_{2\max}$  decreases with increasing  $\nu_2(\theta)$  or  $\theta$  as a consequence of having vertical damping. The values of  $J_{1\max}$ , however, are relatively unaffected by damping. In the vicinity of resonance, both  $J_{1\max}$  and  $J_{2\max}$  grow larger and reach their maximum values after crossing the resonance.

Figure 6 shows the final values and maximum values of  $J_1$  and  $J_2$  as functions of the damping constant,  $\beta$ . The growth of  $J_{2\max}$  is affected more by the values of  $\beta$  than that of  $J_{1\max}$ . In particular, for  $\beta = 0.005$ , after 100 revolutions,  $J_{1\max}$  increases by a factor of 2, but  $J_{2\max}$  returns to its initial value.

### Summary

We have shown that in a one-particle model, and for a linear sum resonance it is possible to obtain a small growth of vertical beam dimensions relative to that of the horizontal dimensions by having sufficient vertical damping. Whether the one-particle model of this paper is an adequate approximation to the n-body problem of a beam, subject to a clearing electrode, has not been studied. However, the interesting results obtained here, strongly motivate further study of this point, especially as the calculation suggests the possibility of generally controlling resonant beam growth by means of damping electrodes.

References

1. See, for example, G. K. Green and E. D. Courant, Handbuch der Physik, Vol. 44 (Springer-Verlag, Berlin, Germany, 1959); p. 312.
2. J. H. Martin, "Radial Beam Instabilities in the Zero Gradient Synchrotron," in Proc. 6th International Conference on High Energy Accelerators, Cambridge, Mass. (1967); p. 423.
3. R. W. Hamming, Numerical Methods for Scientists and Engineers, (McGraw-Hill and Co., New York, 1962); p. 212.

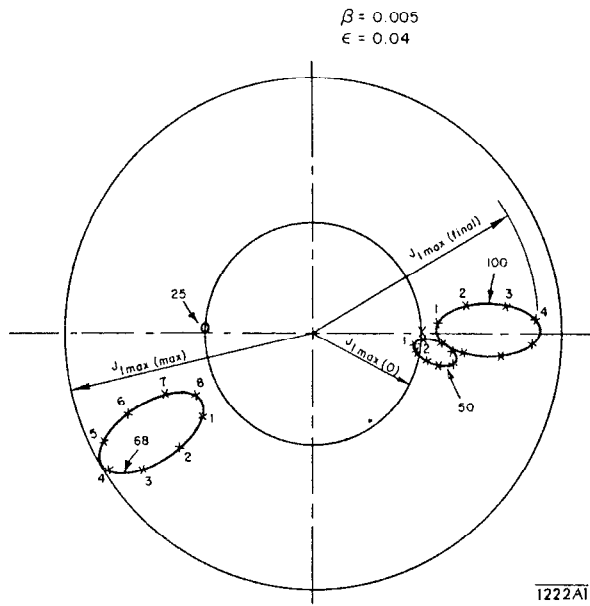

FIG. 1--Particle coordinates  $(J_1, \psi_1)$  after 25, 50, 68 and 100 revolutions for initial coordinate values represented in Fig. 2;  $\nu_1 = 0.3$  and  $\nu_2$  varies linearly from 0.6 to 0.8 in 100 turns.

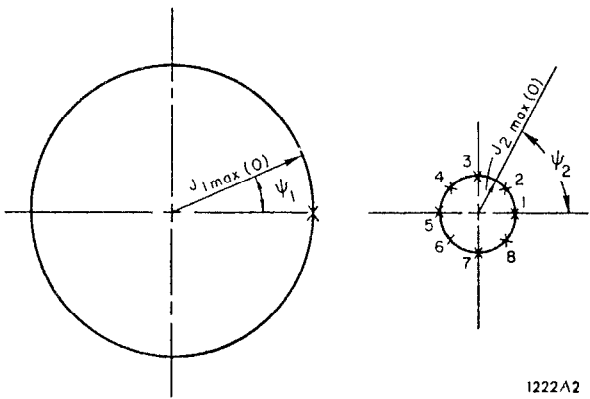

FIG. 2--Initial values of particle coordinates  $(J_1, \psi_1, J_2, \psi_2)$ .

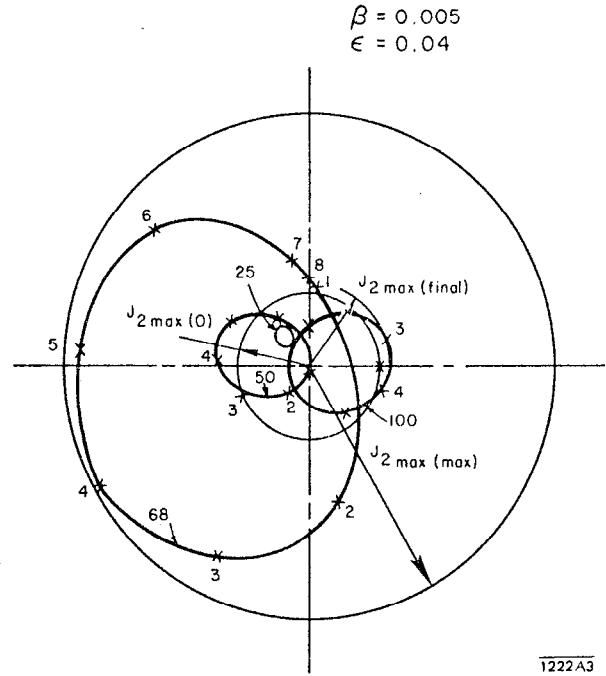

FIG. 3--Particle coordinates  $(J_2, \psi_2)$  after 25, 50, 68 and 100 revolutions for initial coordinate values represented in Fig. 4;  $\nu_1 = 0.3$  and  $\nu_2$  varies linearly from 0.6 to 0.8 in 100 turns.

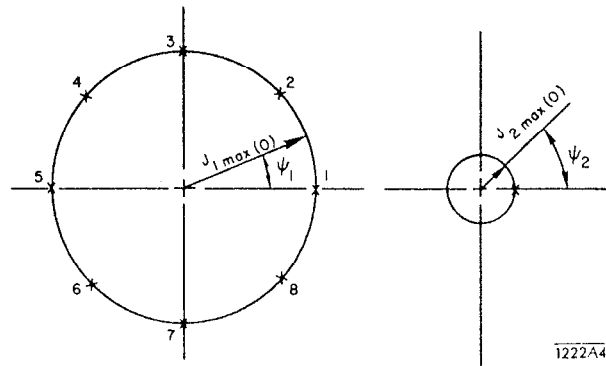

FIG. 4--Initial values of particle coordinates  $(J_1, \psi_1, J_2, \psi_2)$ .

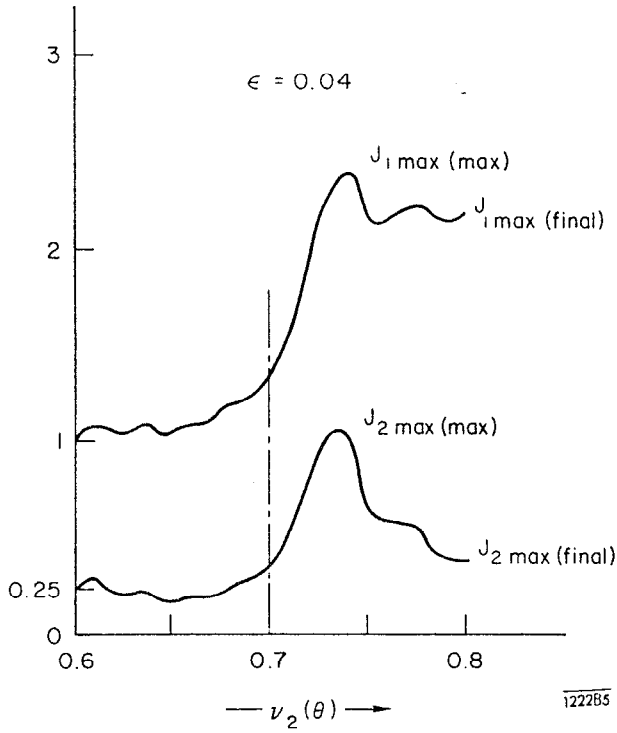

FIG. 5--Growth of beam dimensions in crossing a linear sum resonance at  $\nu_2 = 0.7$  as characterized by the values of  $J_{1\max}$  and  $J_{2\max}$  for the case of  $\beta = 0.004$ .

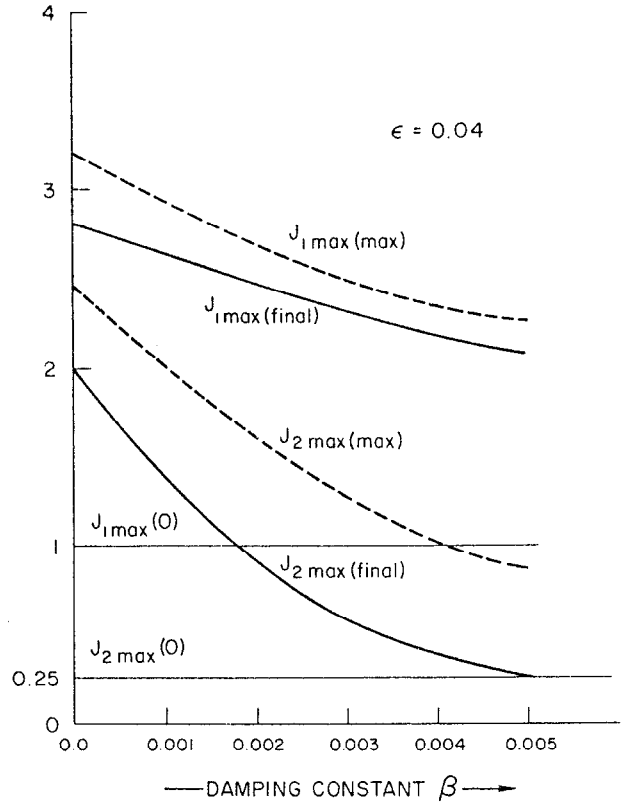

FIG. 6--Effects of damping upon the beam dimensions.