

Comment on "Design Digital Comparators Logically"¹

By recognizing that $(A B + \bar{A} \bar{B}) = \overline{(A \bar{B} + \bar{A} B)}$, the identity function $A=B$ can be more economically implemented using wired outputs on IC gates. The $A=B$ (6 Bit) comparator illustrated below utilizes 6 gates and 6 inverters compared with 10 gates and 7 inverters used in the original design (page 55).

The output is true (HIGH) when every A input is identical to the corresponding B input. If type 930 gates are used, then only 8 outputs can be tied together and drive a following input. If open collector circuits such as the MC858P or SN7401N are used, then the number of outputs which may be paralleled is limited only by speed and leakage currents. (See ED Nov. 7, 1968, pages 80-82).

The general technique described here can be used to advantage in other types of comparators.

(1) Part 1, Electronic Design 23, Nov. 7, 1968 (page 51-57).

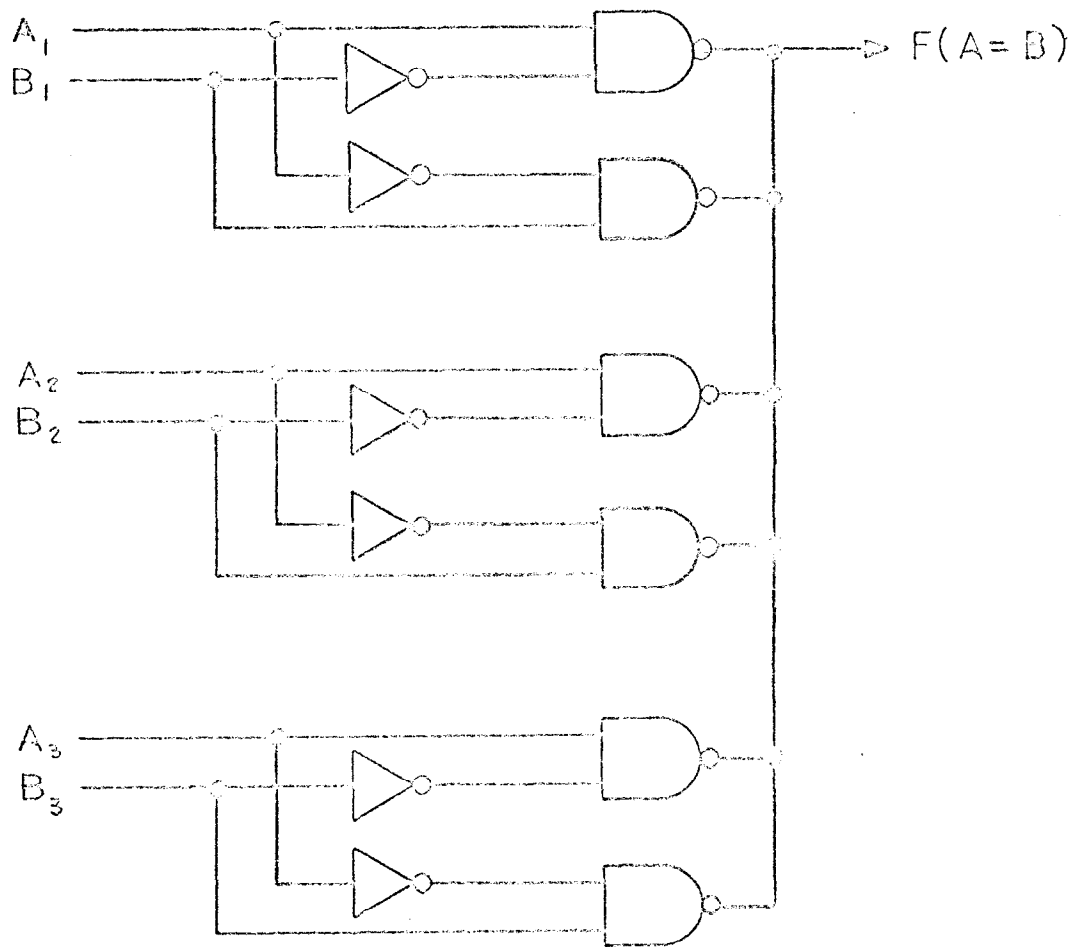

6 BIT IDENTITY COMPARATOR