



**Series IP440 Industrial I/O Pack
32-Channel Isolated Digital Input Module
With Interrupts**

USER'S MANUAL

ACROMAG INCORPORATED

30765 South Wixom Road

P.O. BOX 437

Wixom, MI 48393-7037 U.S.A.

Tel: (248) 624-1541

Fax: (248) 624-9234

Copyright 1996, Acromag, Inc., Printed in the USA.
Data and specifications are subject to change without notice.

8500-551-E01D006

The information contained in this manual is subject to change without notice. Acromag, Inc. makes no warranty of any kind with regard to this material, including, but not limited to, the implied warranties of merchantability and fitness for a particular purpose. Further, Acromag, Inc. assumes no responsibility for any errors that may appear in this manual and makes no commitment to update, or keep current, the information contained in this manual. No part of this manual may be copied or reproduced in any form, without the prior written consent of Acromag, Inc.

Table of Contents	Page
1.0 GENERAL INFORMATION	2
KEY IP440 FEATURES.....	2
INDUSTRIAL I/O PACK INTERFACE FEATURES.....	3
SIGNAL INTERFACE PRODUCTS.....	3
INDUSTRIAL I/O PACK SOFTWARE LIBRARY.....	3
2.0 PREPARATION FOR USE	3
UNPACKING AND INSPECTION.....	3
CARD CAGE CONSIDERATIONS.....	4
BOARD CONFIGURATION.....	4
CONNECTORS.....	4
IP Field I/O Connector (P2).....	4
Noise and Grounding Considerations.....	5
IP Logic Interface Connector (P1).....	5
3.0 PROGRAMMING INFORMATION	5
ADDRESS MAPS.....	5
Standard (Default) Mode Memory Map.....	6
Enhanced Mode Memory Map.....	6
REGISTER DEFINITIONS.....	7
THE EFFECT OF RESET.....	11
IP440 PROGRAMMING.....	11
Basic Input Operation.....	11
Enhanced Operating Mode.....	11
Event Sensing.....	11
Change-Of-State Detection.....	12
Debounce Control.....	12
Interrupt Generation.....	12
Programming Example.....	12
4.0 THEORY OF OPERATION	13
IP440 OPERATION.....	13
LOGIC/POWER INTERFACE.....	14
5.0 SERVICE AND REPAIR	14
SERVICE AND REPAIR ASSISTANCE.....	14
PRELIMINARY SERVICE PROCEDURE.....	14
6.0 SPECIFICATIONS	14
GENERAL SPECIFICATIONS.....	14
INPUTS.....	15
INDUSTRIAL I/O PACK COMPLIANCE.....	15
APPENDIX	15
CABLE: MODEL 5025-550. & 5025-551.....	15
CABLE: MODEL 5029-900.....	15
TERMINATION PANEL: MODEL 5025-552.....	16
TERMINATION PANEL: MODEL 5029-910.....	16
TRANSITION MODULE: MODEL TRANS-GP.....	16
DRAWINGS	Page
4501-434 IP MECHANICAL ASSEMBLY.....	17
4501-593 IP440 FIELD CONNECTIONS.....	17
4501-603 IP440/445 LOOPBACK CONNECTIONS.....	18
4501-594 IP440 BLOCK DIAGRAM.....	18
4501-462 CABLE 5025-550 (NON-SHIELDED).....	19
4501-463 CABLE 5025-551 (SHIELDED).....	19
4501-464 TERMINATION PANEL 5025-552.....	20
4501-465 TRANSITION MODULE TRANS-GP.....	20

IMPORTANT SAFETY CONSIDERATIONS

It is very important for the user to consider the possible adverse effects of power, wiring, component, sensor, or software failures in designing any type of control or monitoring system. This is especially important where economic property loss or human life is involved. It is important that the user employ satisfactory overall system design. It is agreed between the Buyer and Acromag, that this is the Buyer's responsibility.

1.0 GENERAL INFORMATION

The Industrial I/O Pack (IP) Series IP440 module provides 32 channels of isolated digital inputs for interfacing to the VMEbus or ISAbus, according to your carrier board. Four units may be mounted on a single carrier board to provide up to 128 inputs per system slot.

Inputs of this module are bipolar and can be used to sense positive or negative voltages in 3 ranges according to the model:

MODEL	INPUT RANGE	THRESHOLD
IP440-1	± 4V to ±18V DC or AC peak	± 4V Maximum
IP440-2	± 16 to ±40V DC or AC peak	± 16V Maximum
IP440-3	± 38 to ±60V DC or AC peak	± 38V Maximum

MODEL	OPERATING TEMPERATURE RANGE
IP440-X	0 to +70°C
IP440-XE	-40 to +85°C

The inputs normally function as independent input level detectors without interrupts. However, each input line includes built-in event sense circuitry with programmable polarity, debounce, and interrupt support. Inputs also include hysteresis for increased noise immunity. The IP440 utilizes state of the art Surface-Mounted Technology (SMT) to achieve its wide functionality and is an ideal choice for a wide range of industrial I/O applications that require a high-density, highly reliable, high-performance interface at a low cost.

KEY IP440 FEATURES

- **High Channel Count** - Provides programmable monitor and control of 32 optically-isolated input points. Four units mounted on a carrier board provide 128 isolated input points in a single VMEbus or ISAbus (PC/AT) system slot.
- **High-Speed/0 Wait States** - No wait states are required for all read/write cycles (all cycles complete in 250ns) and hold states are supported.
- **Wide Range Bipolar Input Voltage** - Three model ranges provide interface capability for bipolar voltages from ±4 to ±60V DC or AC peak (see Specifications section).
- **Optically Isolated** - Individual bipolar opto-couplers provide isolation. There are four groups (ports) of 8 channels each which include separate port commons to ensure port-to-port isolation. Individual ports are isolated from each other and from the logic.
- **Programmable Polarity Event Interrupts** - Interrupts are software programmable for positive (low-to-high) or negative (high-to-low) input level transitions on all 32 channels. Using two channels per input, change-of-state transitions may also be configured.

- **Input Hysteresis** - Isolated inputs include hysteresis for increased noise immunity.
- **Programmable Debounce** - The event sense input circuitry includes programmable debounce times for all 32 channels. Debounce time is the duration of time that must pass before the input transition is recognized as valid at the ASIC input. This helps prevent false events and increases noise immunity.
- **Reverse Polarity Protection** - Bipolar inputs are not polarized and are inherently reverse polarity protected.
- **No Configuration Jumpers or Switches** - All configuration is performed through software commands with no internal jumpers to configure or switches to set.
- **ASIC Based Monitor** - State of the art ASIC (Application Specific Integrated Circuit from Ziatech Corporation) provides the 32 channel input and event functionality.
- **Loopback Compatible with IP445 Output Module** - The field side P2 pinouts of this model are directly compatible with those of the Acromag Model IP445 32-Channel Digital Output Module for direct closed-loop monitoring of the output states. The IP440 also shares the same P2 pinout used on the Acromag non-isolated IP400 40 Channel Input Module, IP405 40-Channel Output Module, and IP408 32-Channel I/O Module, for channels 0-31. Likewise, this model may interface with industry standard I/O panels, termination panels, and relay racks when used with an Acromag Model 5025-655 I/O Adaptor Card. However, since relay racks generally provide isolation, it may be more efficient to interface with them using the non-isolated IP400 input module.

INDUSTRIAL I/O PACK INTERFACE FEATURES

- **High density** - Single-size, industry standard, IP module footprint. Four units mounted on a carrier board provide up to 128 isolated input points in a single system slot. Both VMEbus and ISAbus (PC/AT) carriers are supported.
- **Local ID** - Each IP module has its own 8-bit ID PROM which is accessed via data transfers in the "ID Read" space.
- **8-bit I/O** - Port register Read/Write is performed through 8-bit data transfer cycles in the IP module I/O space.
- **High Speed with No Wait States** - Access times for all data transfer cycles are described in terms of "wait" states--0 wait states are required for all read and write operations of this model. See Specifications section for detailed information.

SIGNAL INTERFACE PRODUCTS

(See Appendix for more information on compatible products)

This IP module will mate directly to any industry standard IP carrier board (including Acromag AVME9630/9660 3U/6U non-intelligent VMEbus carrier boards). Additionally, PC carrier boards are also supported (see Acromag Model APC8600). A wide range of other Acromag IP modules are also available to serve your signal conditioning and interface needs.

Note: Since all connections to field signals are made through the carrier board which passes them to the individual IP modules, you should consult the documentation of your carrier board to ensure compatibility with the following interface products.

Cables:

Model 5025-551-X (Shielded Cable), or Model 5025-550-X (Non-Shielded Cable): A Flat 50-pin cable with female connectors at both ends for connecting AVME9630/9660, or other compatible carrier boards, to Model 5025-552 termination panels.

The unshielded cable is recommended for digital I/O, while the shielded cable is recommended for optimum performance with precision analog I/O applications. The "-X" suffix of the model number denotes the length in feet.

Model 5029-900 APC8600 High-Density Cable: A 36-inch long interface cable that mates the high-density (25mil pitch) 50-pin I/O connectors of the APC8600 PCbus carrier board, to the high-density connectors on the APC8600 Termination Panel (described below).

Termination Panels:

Model 5025-552: A DIN-rail mountable panel that provides 50 screw terminals for universal field I/O termination. Connects to Acromag AVME9630/9660, or other compatible carrier boards, via flat 50-pin ribbon cable (Model 5025-550-X or 5025-551-X).

Model 5029-910 APC8600 High-Density-to-Screw-Terminal Termination Panel: This panel converts the high-density ribbon-cable connectors coming from the APC8600 carrier board (Acromag cable Model 5029-900) to screw terminals, for direct-wired interfaces.

Transition Module:

Model TRANS-GP: This module repeats field I/O connections of IP modules A through D for rear exit from a VMEbus card cage. It is available for use in card cages which provide rear exit for I/O connections via transition modules (transition modules can only be used in card cages specifically designed for them). It is a double-height (6U), single-slot module with front panel hardware adhering to the VMEbus mechanical dimensions, except for shorter printed circuit board depth. It connects to Acromag Termination Panel 5025-552 from the rear of the card cage, and to AVME9630/9660 boards within the card cage, via flat 50-pin ribbon cable (cable Model 5025-550 or 5025-551).

INDUSTRIAL I/O PACK SOFTWARE LIBRARY

Acromag provides an Industrial I/O Pack Software Library diskette (Model IPSW-LIB-M03, MSDOS format) to simplify communication with the board. Example software functions are provided for both ISAbus (PC/AT) and VMEbus applications. Software functions of the IP440 are shared by the IP470. All functions are written in the "C" programming language and can be linked to your application. For more details, refer to the "README.TXT" file in the root directory on the diskette and the "INFO440.TXT" file in the appropriate "IP470" subdirectory off of "VMEIP" or "PCIP", according to your carrier.

2.0 PREPARATION FOR USE

UNPACKING AND INSPECTION

Upon receipt of this product, inspect the shipping carton for evidence of mishandling during transit. If the shipping carton is badly damaged or water stained, request that the carrier's agent be present when the carton is opened. If the carrier's agent is absent when the carton is opened and the contents of the carton are damaged, keep the carton and packing material for the agent's inspection.

For repairs to a product damaged in shipment, refer to the Acromag Service Policy to obtain return instructions. It is suggested that salvageable shipping cartons and packing material be saved for future use in the event the product must be shipped.

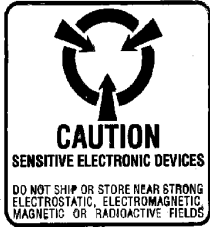

This board is physically protected with packing material and electrically protected with an anti-static bag during shipment. However, it is recommended that the board be visually inspected for evidence of mishandling prior to applying power.

The board utilizes static-sensitive components and should only be handled at a static-safe workstation.

CARD CAGE CONSIDERATIONS

Refer to the specifications for loading and power requirements. Be sure that the system power supplies are able to accommodate the power requirements of the carrier board, plus the installed IP modules, within the voltage tolerances specified.

IMPORTANT: Adequate air circulation must be provided to prevent a temperature rise above the maximum operating temperature.

The dense packing of the IP modules to the carrier board restricts air flow within the card cage and is cause for concern. Adequate air circulation must be provided to prevent a temperature rise above the maximum operating temperature and to prolong the life of the electronics. If the installation is in an industrial environment and the board is exposed to environmental air, careful consideration should be given to air-filtering.

BOARD CONFIGURATION

Power should be removed from the board when installing IP modules, cables, termination panels, and field wiring. Refer to Mechanical Assembly Drawing 4501-434 and your IP module documentation for configuration and assembly instructions. Model IP440 digital input boards have no hardware jumpers or switches to configure.

CONNECTORS

IP Field I/O Connector (P2)

P2 provides the field I/O interface connections for mating IP modules to the carrier board. P2 is a 50-pin female receptacle header (AMP 173279-3 or equivalent) which mates to the male connector of the carrier board (AMP 173280-3 or equivalent). This provides excellent connection integrity and utilizes gold-plating in the mating area. Threaded metric M2 screws and spacers are supplied with the module to provide additional stability for harsh environments (see Mechanical Assembly Drawing 4501-434). The field and logic side connectors are keyed to avoid incorrect assembly.

P2 pin assignments are unique to each IP model (see Table 2.1) and normally correspond to the pin numbers of the field I/O interface connector on the carrier board (you should verify this for your carrier board).

Table 2.1: IP440 Field I/O Pin Connections (P2)

Pin Description	Number	Pin Description	Number		
P O R T 0	IN00	1	P O R T 2	IN16	21
	IN01	2		IN17	22
	IN02	3		IN18	23
	IN03	4		IN19	24
	NC	5		NC	25
	IN04	6		IN20	26
	IN05	7		IN21	27
	IN06	8		IN22	28
	IN07	9		IN23	29
	ACOM	10		CCOM	30
P O R T 1	IN08	11	P O R T 3	IN24	31
	IN09	12		IN25	32
	IN10	13		IN26	33
	IN11	14		IN27	34
	NC	15		NC	35
	IN12	16		IN28	36
	IN13	17		IN29	37
	IN14	18		IN30	38
	IN15	19		IN31	39
	BCOM	20		DCOM	40
		No Connection	41		
		No Connection	42		
		No Connection	43		
		No Connection	44		
		No Connection	45		
		No Connection	46		
		No Connection	47		
		No Connection	48		
		No Connection	49		
		No Connection	50		

Input channels of this module are divided into four ports of eight channels each. Channels of a port share a common signal connection with each other. Isolation is provided between ports and between each port and the IP logic. With respect to interrupt generation and events, event polarities may be defined as positive (low-to-high), or negative (high-to-low) for individual nibbles (groups of 4 input lines, or half ports). Change-of-State detection would require 2 input channels--one detecting positive events, one detecting negative events.

P2 pinouts are arranged to be compatible with similar industry models. This model is directly loopback compatible with the Acromag Model IP445 Digital Output Module. Likewise, pin assignments are identical to those of Acromag Model IP400 40-Channel Digital Input Boards for channels 0-31. This model may also interface with industry accepted I/O panels, termination panels, and relay racks when used with the Acromag Model 5025-655 I/O Adapter Card. Consult the factory for information on these and other compatible products.

Refer to Drawing 4501-593 for example input connections. See Drawing 4501-603 for loopback connections to Acromag Model IP445 Output Modules. Drawing 4501-603 also gives an example of how to interface the IP440-1 with open-drain TTL outputs signals.

Note that the inputs of this device are bipolar, and may be connected in any direction with respect to the port common. Further, do not confuse port commons with signal ground. For the IP440, port common only infers that this lead is connected common to the 8 inputs of the port (a separate port common for each port). Likewise, the port commons of the IP440 input module and IP445 output module are normally not connected together for loopback interconnection (see Drawing 4501-603).

Noise and Grounding Considerations

Input lines of the IP440 are optically isolated between the logic and field input connections. Likewise, separate port commons facilitate port-to-port isolation. Consequently, the field I/O connections are isolated from the carrier board and backplane, thus minimizing the negative effects of ground bounce, impedance drops, and switching transients. However, care should be taken in designing installations to avoid inadvertent isolation bridges, noise pickup, isolation voltage clearance violations, equipment failure, or ground loops.

IP Logic Interface Connector (P1)

Table 2.2: Standard Logic Interface Connections (P1)

Pin Description	Number	Pin Description	Number
GND	1	GND	26
CLK	2	+5V	27
Reset*	3	R/W*	28
D00	4	IDSEL*	29
D01	5	<i>DMAReq0*</i>	30
D02	6	MEMSEL*	31
D03	7	<i>DMAReq1*</i>	32
D04	8	IntSel*	33
D05	9	<i>DMAck0*</i>	34
D06	10	IOSEL*	35
D07	11	<i>RESERVED</i>	36
<i>D08</i>	12	A1	37
<i>D09</i>	13	<i>DMAEnd*</i>	38
<i>D10</i>	14	A2	39
<i>D11</i>	15	<i>ERROR*</i>	40
<i>D12</i>	16	A3	41
<i>D13</i>	17	INTRReq0*	42
<i>D14</i>	18	A4	43
<i>D15</i>	19	<i>INTRReq1*</i>	44
BS0*	20	A5	45
<i>BS1*</i>	21	<i>STROBE*</i>	46
-12V	22	A6	47
+12V	23	ACK*	48
+5V	24	<i>RESERVED</i>	49
GND	25	GND	50

An Asterisk (*) is used to indicate an active-low signal. **BOLD ITALIC** Logic Lines are NOT USED by this IP Model.

P1 of the IP module provides the logic interface to the mating connector on the carrier board. The pin assignments of P1 are standard for all IP modules according to the Industrial I/O Pack Specification (see Table 2.2). This connector is a 50-pin female receptacle header (AMP 173279-3 or equivalent) which mates to the male connector of the carrier board (AMP 173280-3 or equivalent). This provides excellent connection integrity and utilizes gold-plating in the mating area.

Threaded metric M2 screws and spacers are supplied with the IP module to provide additional stability for harsh environments (see Drawing 4501-434 for assembly details). Field and logic side connectors are keyed to avoid incorrect assembly.

3.0 PROGRAMMING INFORMATION

ADDRESS MAPS

This board is addressable in the Industrial Pack I/O space to control the configuration and status monitoring of 32 digital input or event channels.

This board operates in two modes: Standard Mode and Enhanced Mode. Standard Mode provides digital input voltage monitoring of 32 isolated signal lines. In Standard Mode, each input line is configured as a simple input without interrupts. Data is read from (or written to) one of eight groups (ports) as designated by the address and read and write signals. The ASIC of this model is capable of I/O, but this model is intended for input only. A Mask Register is used to disable writes to I/O ports designed for input only. Enhanced Mode includes the same functionality of Standard Mode, but adds access to 32 additional event sense inputs connected to each input point of ports 0-3. Individual inputs also include selectable hardware debounce in Enhanced Mode. For event sensing, the Enhanced Mode allows a specific input level transition (High-to-Low, Low-to-High, or Change-of-State) to be detected and optionally generate an interrupt.

Memory is organized and addressed in separate banks of eight registers or ports (eight ports to a bank). The Standard Mode of operation addresses the first group of 8 registers or ports (ports 0-3 for reading inputs, Ports 4, 5, & 6 which are not used on this model, and Port 7 which is the Mask Register). The mask register is included to mask writes to input points, since the input points of this model are intended for input only, while the digital ASIC is capable of output control. If the Enhanced Mode is selected, then 3 additional banks of 8 registers are accessed to cover the additional functionality in this mode (events, interrupts, and debounce). The first bank of the Enhanced Mode (bank 0) is similar in operation to the Standard Mode. The second bank (bank 1) provides event sense and interrupt control. The third bank is used to configure the debounce circuitry to be applied to input channels in the Enhanced Mode. Two additional mode-independent registers are provided to enable the interrupt request line, generate a software reset, and store the interrupt vector.

The I/O space may be as large as 64, 16-bit words (128 bytes) using address lines A1..A6, but the IP440 uses only a portion of this space. The I/O space address map for the IP440 is shown in Table 3.1. Note the base address for the IP module I/O space (see your carrier board instructions) must be added to the addresses shown to properly access the I/O space. All accesses are performed on an 8-bit byte basis (D0..D7).

This manual is presented using the "Big Endian" byte ordering format. Big Endian is the convention used in the Motorola 68000 microprocessor family and is the VMEbus convention. In Big Endian, the lower-order byte is stored at odd-byte addresses. Thus, byte accesses are done on odd address locations. The Intel x86 family of microprocessors use the opposite convention, or "Little Endian" byte ordering. Little Endian uses even-byte addresses to store the low-order byte. As such, use of this module on an ISA bus (PC/AT) carrier board will require the use of the even address locations to access the 8-bit data, while a VMEbus carrier will require the use of odd address locations.

Note that some functions share the same register address. For these items, the address lines are used along with the read and write signals to determine the function required.

Standard (Default) Mode Memory Map

The following table shows the memory map for the Standard Mode of operation. This is the Default mode reached after power-up or system reset. Standard Mode provides simple monitoring of 32 digital input lines without interrupts. Data is read from or written to one of eight groups (ports) as designated by the address and read and write signals. A Mask Register is used to disable writes to input ports, since this model is intended for input only. That is, the ASIC used by this model is capable of output, and since this model is intended for input only, then each port (group of 8 input lines) must be blocked (masked) from writes.

To switch to Enhanced Mode, four unique bytes must be written to port 7, in consecutive order, without doing any reads or writes to any other port and with interrupts disabled. The data pattern to be written is 07H, 0DH, 06H, and 12H, and this must be written after reset or power-up.

Table 3.1A: IP440 R/W Space Address (Hex) Memory Map

EVEN Base Addr+	MSB		LSB		ODD Base Addr+
	D15	D08	D07	D00	
STANDARD MODE (DEFAULT) REGISTER DEFINITIONS:					
00	Not Driven ⁴		READ ¹ - Port 0 Register IN00-IN07		01
02	Not Driven ⁴		READ ¹ - Port 1 Register IN08-IN15		03
04	Not Driven ⁴		READ ¹ - Port 2 Register IN16-IN23		05
06	Not Driven ⁴		READ ¹ - Port 3 Register IN24-IN31		07
08	Not Driven ⁴		READ/WRITE ² - Port 4 NOT USED		09
0A	Not Driven ⁴		READ/WRITE ² - Port 5 NOT USED		0B
0C	Not Driven ⁴		READ/WRITE ² - Port 6 NOT USED		0D
0E	Not Driven ⁴		READ/WRITE - Port 7 WRITE MASK REGISTER AND ENHANCED MODE SELECT REGISTER ³		0F
10 ↓ 7E	NOT USED ⁵				11 ↓ 7F

Notes (Table 3.1A):

- Writes to these registers are possible, but this model is intended for input only and writes should not be done. Writes to these registers may be blocked via the Write Mask Register of Port 7.
- The ASIC of this model is capable of a greater channel count, but only 32 channels are used by this model, and as a result, ports 4, 5, & 6 are not used.
- Writing four unique bytes (07H, 0DH, 06H, and 12H) to port 7, in consecutive order, will switch to Enhanced Mode. Do this without doing any reads or writes to any other port, with interrupts disabled, and after reset or power-up.
- The upper 8 bits of these registers are not driven and pullups on the carrier data bus will cause these bits to read high (1's).
- The IP will not respond to addresses that are "Not Used".

Enhanced Mode Memory Maps

The following table shows the memory maps used for the Enhanced Mode of operation. Enhanced Mode includes the same functionality of Standard Mode, but allows each input port's event sense input and debounce logic to be enabled.

In Enhanced Mode, a memory map is given for each of 3 memory banks. The first memory bank (bank 0) has the same functionality as the Standard Mode. Additionally, its port 7 register is used to select which bank to access (similar to Standard Mode where port 7 was used to select the Enhanced Mode). Bank 1 provides read/write access to the 32 event sense inputs. Bank 2 provides access to the registers used to control the debounce circuitry of these event sense inputs.

Table 3.1B: IP440 R/W Space Address (Hex) Memory Map

EVEN Base Addr+	MSB		LSB		ODD Base Addr+
	D15	D08	D07	D00	
ENHANCED MODE, REGISTER BANK [0] DEFINITIONS:					
00	Not Driven ¹		READ ⁴ - Port 0 Register IN00-IN07		01
02	Not Driven ¹		READ ⁴ - Port 1 Register IN08-IN15		03
04	Not Driven ¹		READ ⁴ - Port 2 Register IN16-IN23		05
06	Not Driven ¹		READ ⁴ - Port 3 Register IN24-IN31		07
08	Not Driven ¹		READ/WRITE ⁵ - Port 4 NOT USED		09
0A	Not Driven ¹		READ/WRITE ⁵ - Port 5 NOT USED		0B
0C	Not Driven ¹		READ/WRITE ⁵ - Port 6 NOT USED		0D
0E	Not Driven ¹		READ - Port 7 READ MASK REGISTER (Also Current Bank Status)		0F
0E	Not Driven ¹		WRITE - Port 7 WRITE MASK REGISTER (Also Bank Select Register)		0F

Table 3.1B: IP440 R/W Space Address (Hex) Memory Map

EVEN Base Addr+	MSB		LSB		ODD Base Addr+
	D15	D08	D07	D00	
ENHANCED MODE, REGISTER BANK [1] DEFINITIONS:					
00	Not Driven ¹		READ - Port 0 Event Sense Status Reg. (Port 0 Input points 0-7)		01
00	Not Driven ¹		WRITE - Port 0 Event Sense Clear Register (Port 0 Input points 0-7)		01
02	Not Driven ¹		READ - Port 1 Event Sense Status Reg. (Port 1 Input points 8-15)		03
02	Not Driven ¹		WRITE - Port 1 Event Sense Clear Register (Port 1 Input points 8-15)		03
04	Not Driven ¹		READ - Port 2 Event Sense Status Reg. (Port 2 Input points 16-23)		05
04	Not Driven ¹		WRITE - Port 2 Event Sense Clear Register (Port 2 Input points 16-23)		05
06	Not Driven ¹		READ - Port 3 Event Sense Status Reg. (Port 3 Input points 24-31)		07
06	Not Driven ¹		WRITE - Port 3 Event Sense Clear Register (Port 3 Input points 24-31)		07
08	Not Driven ¹		READ - Port 4 NOT USED		09
08	Not Driven ¹		WRITE - Port 4 NOT USED		09
0A	Not Driven ¹		READ - Port 5 NOT USED		0B
0A	Not Driven ¹		WRITE - Port 5 NOT USED		0B
0C	Not Driven ¹		READ - Port 6 Event Status for Ports 0-3 and Interrupt Status Reg.		0D
0C	Not Driven ¹		WRITE - Port 6 Event Polarity Control Register for Port 0-3		0D
0E	Not Driven ¹		READ - Port 7 Current Bank Status Reg.		0F
0E	Not Driven ¹		WRITE - Port 7 Bank Select Register		0F
ENHANCED MODE, REGISTER BANK [2] DEFINITIONS:					
00	Not Driven ¹		READ/WRITE - Port 0 Debounce Control Register (for Ports 0-3)		01
02	Not Driven ¹		READ/WRITE - Port 1 Debounce Duration Reg. 0 (for Ports 0-3)		03
04	Not Driven ¹		NOT USED		05
06	Not Driven ¹		WRITE ONLY - Port 3 Debounce Clock Select		07
08 ↓ 0C	Not Driven ¹		Port 4,5,6 NOT USED ²		09 ↓ 0D
0E	Not Driven ¹		READ/WRITE - Port 7 Bank Status/Select Register		0F

Table 3.1B: IP440 R/W Space Address (Hex) Memory Map

EVEN Base Addr+	MSB		LSB		ODD Base Addr+
	D15	D08	D07	D00	
INDEPENDENT FIXED FUNCTION REGISTERS:					
10 ↓ 1C	NOT USED ²				11 ↓ 1D
1E	Not Driven ¹		READ/WRITE Interrupt Enable Register (Bit 0=1 enables INTREQ0) & Software Reset Generator (Bit 1=1 Generates Reset)		1F
20 ↓ 2C	NOT USED ²				21 ↓ 2D
2E	Not Driven ¹		READ/WRITE Interrupt Vector Register		2F
30 ↓ 7E	NOT USED ²				31 ↓ 7F

Notes (Table 3.1B):

1. The upper 8 bits of these registers are not driven and pullups on the carrier data bus will cause these bits to read high (1's).
2. The IP will not respond to addresses that are "Not Used".
3. All Reads and Writes are 0 wait state.
4. Writes to these registers are possible, but this model is intended for input only and writes should not be done. Writes to these registers may be blocked via the Write Mask Register of Port 7.
5. The ASIC of this model is capable of a greater channel count, but only 32 channels are used by this model, and as a result, ports 4, 5, & 6 are not used.

REGISTER DEFINITIONS

STANDARD MODE REGISTERS

**Port Registers
(Standard Mode, Ports 0-3, Read, Write Restricted)**

Four registers are provided to monitor 32 possible input points. Data is read from one of four groups of eight input lines (Ports 0-3), as designated by the address and read and write signals. Each port assigns the least significant data line (D0) to the least significant input line of the port grouping (e.g. IN00 for port 0 to D0). A read of this register returns the status (ON/OFF) of the input point. Although the ASIC used by this model is capable of output, the IP440 is intended for input only and writes to these registers should be blocked. Writing '1' to this register will cause the input to always read as 0, and changes in the input will be ignored (until a 0 is written or a reset occurs). A Mask Register is used to disable writes to ports intended for input only. That is, each port (group of 8 input lines) should be masked from writes.

On power-up or reset, the ports are reset to 0, forcing the outputs to be set high/OFF (outputs are not used by this model).

Write Mask Register & Enhanced Mode Select Register (Standard Mode, Port 7, Read/Write)

The ASIC used by the IP440 is capable of output. However, the ports of this model are intended for input only and writes to these ports should be avoided. This register is used to mask the ability to write data to the four I/O ports of this model. Writing a '1' to bits 0-3 of the Mask Register will mask ports 0-3 respectively, from inadvertent writes. A read of this register will return the status of the mask in bits 0-3.

Standard Mode Write Mask Register (Port 7)

BIT	WRITE TO REGISTER	READ FROM REGISTER
0	Port 0 Write Mask	Port 0 Write Mask
1	Port 1 Write Mask	Port 1 Write Mask
2	Port 2 Write Mask	Port 2 Write Mask
3	Port 3 Write Mask	Port 3 Write Mask
4-7	NOT USED	NOT USED

Bits 4-7 of this register are not used. On power-up reset, this register defaults to the unmasked state, allowing writes to the output ports.

This register is also used to select the Enhanced Mode of operation. To switch to Enhanced Mode, four unique bytes must be written to port 7, in consecutive order, without doing any reads or writes to any other port and with interrupts disabled. The data pattern to be written is 07H, 0DH, 06H, and 12H, in order, and this must be written immediately after reset or power-up.

ENHANCED MODE

BANK 0 REGISTERS

Port Registers (Enhanced Mode Bank 0, Ports 0-3, Read, Write Restricted)

Four input registers are provided to monitor 32 possible input points. Data is read from one of four groups (Ports 0-3) of eight input lines, as designated by the address. Each port assigns the least significant data line (D0) to the least significant input line of the port grouping (e.g. IN00 of port 0 to D0). A read of this register returns the status (ON/OFF) of the input signal. Although the ASIC used by this model is capable of output, the IP440 is intended for input only and writes to these registers should be blocked. Writing '1' to this register will cause the input to always read as 0, and changes in the input will be ignored (until a 0 is written or a reset occurs). A Mask Register is used to disable writes to ports intended for input only. That is, each port (group of 8 input lines) should be masked from writes (see below).

Write Mask Register And Bank Select Register 0 (Enhanced Mode Bank 0, Port 7, Read/Write)

The ASIC used by the IP440 is capable of output. However, the ports of this model are intended for input only and writes to these ports should be avoided. This register is used to mask the ability to write data to the four I/O ports of this model. Writing a '1' to bits 0-3 of the Mask Register will mask ports 0-3 respectively, from inadvertent writes. A read of this register will return the status of the mask in bits 0-3.

Enhanced Mode Write Mask Register (Port 7)

BIT	WRITE TO REGISTER	READ FROM REGISTER
0	Port 0 Write Mask	Port 0 Write Mask
1	Port 1 Write Mask	Port 1 Write Mask
2	Port 2 Write Mask	Port 2 Write Mask
3	Port 3 Write Mask	Port 3 Write Mask
4-5	NOT USED	NOT USED
6	Bank Select Bit 0	Bank Status Bit 0
7	Bank Select Bit 1	Bank Status Bit 1

Bits 6 & 7 of this register are used to select/monitor the bank of registers to be addressed. In Enhanced Mode, three banks (banks 0-2) of eight registers may be addressed. Bank 0 registers are similar to the Standard Mode bank of registers. Bank 1 allows the 32 event inputs to be monitored and controlled. Bank 2 registers control the debounce circuitry of the event inputs. Bits 7 and 6 select the bank as follows:

Enhanced Mode Bank Select

Bit 7 Bit 6	BANK OF REGISTERS
00	Bank 0 - Read Input Signals
01	Bank 1 - Event Status/Clear
10	Bank 2 - Event Debounce Control, Clock, and Duration
11	INVALID - DO NOT WRITE

On power-up reset, this device is put into the Standard Mode and this register defaults to the unmasked state (allowing writes to the ports which should be avoided), and bank 0 (Default).

BANK 1 REGISTERS

Event Sense Status & Clear Registers For IN00-IN31 (Enhanced Mode Bank 1, Ports 0-3, Read/Write)

Each input line of each port includes an event sense input. Reading each port will return the status of each input port's sense lines. Writing '0' to a bit position of each port will clear the event on the corresponding line. When writing ports 0-3 of Enhanced Mode bank 1, each data bit written with a logic 0 clears the corresponding event sense flip/flop. Further, each data bit of ports 0-3 must be written with a 1 to re-enable the corresponding event sense input after it is cleared. Reading ports 0-3 of the Enhanced Mode bank 1 returns the current event sense flip/flop status.

Port 0 Event Sense/Status Register (Ports 1-3 are Similar)

BIT	READ PORT	WRITE "0"	WRITE "1"
0	Port 0 IN00 Event Status	Clear IN00 Event Sense Flip/Flop	Re-enable IN00 Event Sense
1	Port 0 IN01 Event Status	Clear IN01 Event Sense Flip/Flop	Re-enable IN01 Event Sense
2	Port 0 IN02 Event Status	Clear IN02 Event Sense Flip/Flop	Re-enable IN02 Event Sense
3	Port 0 IN03 Event Status	Clear IN03 Event Sense Flip/Flop	Re-enable IN03 Event Sense
4	Port 0 IN04 Event Status	Clear IN04 Event Sense Flip/Flop	Re-enable IN04 Event Sense
5	Port 0 IN05 Event Status	Clear IN05 Event Sense Flip/Flop	Re-enable IN05 Event Sense
6	Port 0 IN06 Event Status	Clear IN06 Event Sense Flip/Flop	Re-enable IN06 Event Sense
7	Port 0 IN07 Event Status	Clear IN07 Event Sense Flip/Flop	Re-enable IN07 Event Sense

**Event Interrupt Status Register For Ports 0-3
(Enhanced Mode Bank 1, Port 6, Read Only)**

Reading this register will return the event interrupt status of input ports 0-3 (bits 0-3) and the interrupt status flag (bit 7). Bit 7 of this register indicates an event sense was detected on any of the 4 event sense ports ("1" = interrupt asserted/event sensed). Note that the interrupt status flag may optionally drive the Interrupt Request Line of the carrier board (see Interrupt Enable Register).

Event Interrupt Status Register For Ports 0-3

BIT	READ EVENT STATUS REGISTER
0	Port 0 Interrupt Status (IN00-IN07)
1	Port 1 Interrupt Status (IN08-IN15)
2	Port 2 Interrupt Status (IN16-IN23)
3	Port 3 Interrupt Status (IN24-IN31)
4-6	NOT USED
7	Interrupt Status Flag

**Event Polarity Control Register For Ports 0-3
(Enhanced Mode Bank 1, Port 6, Write Only)**

A write to this register controls the polarity of the input sense event for nibbles of ports 0-3 (channels 0-31, four channels at a time). A "1" written to a bit in this register will cause the corresponding event sense input lines to flag negative events (high-to-low transitions). A "0" will cause positive events to be sensed (low-to-high transitions). The polarity of the event sense logic must be set prior to enabling the event input logic. Note that no events will be detected until enabled via the Event Sense Status & Clear Register. Further, interrupts will not be reported to the carrier board unless control of Interrupt Request Line 0 has been configured via the Interrupt Enable Register.

Event Polarity Control Register

BIT	WRITE "1" (NEGATIVE)	WRITE "0" (POSITIVE)
0	Negative Events on Port 0 IN00 through IN03	Positive Events on Port 0 IN00 through IN03
1	Negative Events on Port 0 IN04 through IN07	Positive Events on Port 0 IN04 through IN07
2	Negative Events on Port 1 IN08 through IN11	Positive Events on Port 1 IN08 through IN11
3	Negative Events on Port 1 IN12 through IN15	Positive Events on Port 1 IN12 through IN15
4	Negative Events on Port 2 IN16 through IN19	Positive Events on Port 2 IN16 through IN19
5	Negative Events on Port 2 IN20 through IN23	Positive Events on Port 2 IN20 through IN23
6	Negative Events on Port 3 IN24 through IN27	Positive Events on Port 3 IN24 through IN27
7	Negative Events on Port 3 IN28 through IN31	Positive Events on Port 3 IN28 through IN31

**Bank Select Register
(Enhanced Mode Bank 1, Port 7, Write Only)**

Bits 6 & 7 of this register are used to select/monitor the bank of registers to be addressed. In Enhanced Mode, three banks (banks 0-2) of eight registers may be addressed. Bank 0 is similar to the Standard Mode bank of registers. Bank 1 allows the 32 event inputs to be monitored and controlled. Bank 2 registers control the debounce circuitry of the event inputs. Bits 0-5 of this register are not used. Bits 7 and 6 select the bank as follows:

Bank Select Register

BIT	Function
0-5	NOT USED
6	Bank Select Bit 0
7	Bank Select Bit 1

Bank Select Register (Write)

Bit 7 Bit 6	BANK OF REGISTERS
00	Bank 0 - Read Inputs
01	Bank 1 - Event Status/Clear
10	Bank 2 - Event Debounce Control, Clock, and Duration
11	INVALID - DO NOT WRITE

**Bank Select Status Register 1
(Enhanced Mode Bank 1, Port 7, Read Only)**

Bits 0-5 of this register are not used. Bits 6 & 7 of this register are used to indicate the bank of registers to be addressed. In Enhanced Mode, three banks (banks 0-2) of eight registers may be addressed. Bank 0 is similar to the Standard Mode bank of registers. Bank 1 allows the 32 event inputs to be monitored and controlled. Bank 2 registers control the debounce circuitry of the event inputs. Bits 7 and 6 of this register select the bank as follows:

Bank Selected Status Register (Read)

Bit 7 Bit 6	BANK OF REGISTERS
00	Bank 0 - Read Inputs
01	Bank 1 - Event Status/Clear
10	Bank 2 - Event Debounce Control, Clock, & Duration
11	INVALID - DO NOT WRITE

BANK 2 REGISTERS

**Debounce Control Register
(Enhanced Mode Bank 2, Port 0, Read/Write)**

This register is used to control whether each individual port is to be passed through the debounce logic before being recognized by the circuitry. A "0" disables the debounce logic, and a "1" enables the debounce logic. Debounce applies to both inputs and event sense inputs, and only in Enhanced Mode.

Debounce Control Register

BIT	DEBOUNCE CONTROL
0	Port 0 (IN00-IN07)
1	Port 1 (IN08-IN15)
2	Port 2 (IN16-IN23)
3	Port 3 (IN24-IN31)
4-7	NOT USED

"0"	"1"
Disable	Enable

**Debounce Duration Register 0
(Enhanced Mode Bank 2, Port 1, Read/Write)**

This register controls the duration required by each input signal before it is recognized by each individual ASIC input in the Enhanced Mode. Register 0 controls debounce for ports 0-3. If the debounce clock has been selected (see Debounce Clock Select Register), then the 8MHz IP system clock will allow the debounce times shown below to be selected (actual times vary to within minus 25% of nominal). Note that this time applies to the ASIC input and does not include the optocoupler time delay.

Debounce Duration Register 0:

BIT	DEBOUNCE CONTROL
0	Port 0 Debounce Value Bit 0
1	Port 0 Debounce Value Bit 1
2	Port 1 Debounce Value Bit 0
3	Port 1 Debounce Value Bit 1
4	Port 2 Debounce Value Bit 0
5	Port 2 Debounce Value Bit 1
6	Port 3 Debounce Value Bit 0
7	Port 3 Debounce Value Bit 1

Duration (8MHz):

Bit 1,0	Time
00	3-4us
01	48-64us
10	0.75-1ms
11	6-8ms

Note that with the 8MHz clock enabled, a debounce value of 00 sets 3-4us, 01 sets 48-64us, 10 sets 0.75-1ms, and 11 sets 6-8ms. The default value is 00, setting a 3-4us debounce period. This register is cleared following a reset (setting debounce to 3-4us). Note that the debounce clock must be reselected to re-enable debounce following a reset (see below).

Debounce Clock Select Register (Enhanced Mode Bank 2, Port 3, Write Only)

This register selects the source clock for the event sense input debounce circuitry. If bit 0 of this register is 0 (default value), then the debounce source clock is disabled. If bit 0 is set to 1, then the 8MHz IP bus clock is enabled. This bit must be programmed to "1" to use debounce. Bits 1-7 of this register are not used and will always read as zero. This register is cleared following a reset, disabling use of the 8MHz debounce clock.

Bank Select (Write) & Status (Read) Register 2 (Enhanced Mode Bank 2, Port 7, Read and Write)

Bits 0-5 of this register are not used. Bits 6 & 7 of this register are used to indicate (read) or select (write) the bank of registers to be addressed. In Enhanced Mode, three banks (banks 0, 1, & 2) of eight registers may be addressed. Bank 0 registers are similar to the Standard Mode bank of registers. Bank 1 allows the 32 event inputs to be monitored and controlled. Bank 2 registers control the debounce circuitry of the event inputs. Bits 7 and 6 select/indicate the bank as follows:

Bank Select (Write) & Status(Read) Register

Bit 7 Bit 6	BANK OF REGISTERS
00	Bank 0 - Read Input Signals
01	Bank 1 - Event Status/Clear
10	Bank 2 - Event Debounce Control, Clock, & Duration
11	INVALID - DO NOT WRITE

INDEPENDENT FIXED FUNCTION CONTROL REGISTERS

Interrupt Enable & Software Reset Register (Read/Write)

Bit 0 of this register specifies if the internal event sense interrupts are to be reported to the carrier or not (i.e. whether they drive INTREQ0 or not). This bit defaults to 0 (interrupt request disabled) and event interrupts are only flagged internally. That is, you would have to poll the Event Status Register to determine if an interrupt had occurred, and the INTREQ0 line would not be driven. If bit 0 of this register is set to "1", then interrupts will drive the INTREQ0 line and permit Interrupt Select Cycles (INTSEL) to occur. This bit is cleared following a system reset, but not a software reset (see below).

Writing a 1 to the bit 1 position of this register will cause a software reset to occur (be sure to preserve the current state of bit 0 when conducting a software reset). This bit is not stored and merely acts as a trigger for software reset generation (this bit will always readback as 0). The effect of a software reset is similar to a carrier reset, except that it is not driven by the carrier and it only resets the digital ASIC chip that provides the field interface functions. Likewise, the Interrupt Vector Register or the Interrupt Enable Bit of this register are not cleared in response to a software reset (these are not stored in the ASIC). This control is useful for use with some ISA carriers which do not implement the bus reset control. Bits 2-7 of this register are not used and will always read high (1's).

Interrupt Vector Register (Read/Write)

This 8-bit read/write register is used to store the interrupt vector that will be served (read) during an interrupt select cycle. In response to an interrupt select cycle, the IP module will execute a read of this register. Interrupts are only generated for events while in the Enhanced Mode (see Interrupt Enable register). This register is cleared following a system reset, but not a software reset. Note that interrupts will not be reported to the carrier board unless control of the Interrupt Request Line 0 (IntReq0) has been enabled via the Interrupt Enable Register (IER).

IP Identification PROM - (Read Only, 32 Odd-Byte Addresses)

Each IP module contains an identification (ID) PROM that resides in the ID space per the IP module specification. This area of memory contains 32 bytes of information at most. Both fixed and variable information may be present within the ID PROM. Fixed information includes the "IPAC" identifier, model number, and manufacturer's identification codes. Variable information includes unique information required for the module. The IP440 ID PROM does not contain any variable (e.g. unique calibration) information. ID PROM bytes are addressed using only the odd addresses in a 64 byte block (on the "Big Endian" VMEbus). Even addresses are used on the "Little Endian" PC bus. The IP440 ID PROM contents are shown in Table 3.2. Note that the base-address for the IP module ID space (see your carrier board instructions) must be added to the addresses shown to properly access the ID PROM.

Table 3.2: IP440 ID Space Identification (ID) PROM

Hex Offset From ID PROM Base Address	ASCII Character Equivalent	Numeric Value (Hex)	Field Description
01	I	49	All IP's have 'IPAC'
03	P	50	
05	A	41	
07	C	43	
09		A3	Acromag ID Code
0B		10	IP Model Code ¹
0D		00	Not Used (Revision)
0F		00	Reserved
11		00	Not Used (Driver ID Low Byte)
13		00	Not Used (Driver ID High Byte)
15		0C	Total Number of ID PROM Bytes
17		3B	CRC
19 to 3F		yy	Not Used

Notes (Table 3.2):

1. The IP model number is represented by a two-digit code within the ID PROM (the IP440 model is represented by 10 Hex).
2. Execution of an ID PROM read requires 0 wait states.

THE EFFECT OF RESET

A power-up or bus-initiated software reset will place the module in the Standard Operating Mode (input only, no event sensing, no interrupts, and no debounce). A reset will also clear the mask register and enable writes to the input points of the ASIC (input lines of this model should be masked from writes). Further, all event inputs are reset, set to positive events, and disabled following reset. A false input signal is ensured for inputs left floating (i.e. reads as 0). The Interrupt Enable Register (IER) and Interrupt Vector Register (IVR) are also cleared (except for IER generated software resets).

Another form of software reset (IER register initiated) acts similar to a carrier or power-up reset, except that it is not driven by the carrier and only resets the digital ASIC chip installed on the module. As such, the Interrupt Vector Register and Interrupt Enable Register are not cleared for a software reset initiated in this manner since they are implemented within the PLD (writing a 1 to the bit 1 position of the IER Register will cause this type of software reset to occur). Reset in this manner has been provided for use with some ISA carriers which do not implement the bus reset control, or when the interrupt vector and interrupt enable information must be preserved following reset.

IP440 PROGRAMMING

Acromag provides an Industrial I/O Pack Software Library diskette (Model IPSW-LIB-M03, MSDOS format) to simplify communication with the board. Example software functions are provided for both ISA bus (PC/AT) and VMEbus applications. All functions are written in the "C" programming language and can be linked to your application. For more details, refer to the "README.TXT" file in the root directory on the diskette and the "INFO440.TXT" file in the appropriate "IP440" subdirectory off of "\VMEIP" or "\PCIP", according to your carrier.

Basic Input Operation

Note that the input lines of this module are assembled in groups of eight. Each group of eight lines is referred to as a port. Ports 0-3 control and monitor input lines 0-31. Additionally, ports are grouped eight to a bank. There are four banks of ports used for controlling this module (Standard Mode, plus Enhanced Mode Banks 0, 1, and 2), plus 2 additional registers for enabling the interrupt request line, generating a software reset, and storing the interrupt vector.

Each port input line is bipolar and accepts both positive and negative input voltages in two ranges according to the model number. Individual input lines of a port share a common signal connection with each other. Separate commons are provided for each port to facilitate port-to-port isolation. A high signal is derived from the absolute value of the input voltage measured between the input line and the port common for the input ranges of 4-18V (IP440-1 models), 16-40V (IP440-2 models), and 38-60V (IP440-3 models). Inputs are non-inverting and inputs left floating (not recommended) will register a low (false=0) input indication.

In both the Standard and Enhanced operating modes, each group of eight parallel input lines (a port) are isolated and gated to the data bus D0..D7 lines. A high input will read as "1" and all inputs include hysteresis and programmable debounce. Because the ASIC used by this model is capable of output, individual ports should be masked from writes to the port since they are intended for input only.

Enhanced Operating Mode

In the Enhanced Mode of operation, each port input may act as an event sensor and generate interrupts. Likewise, programmable debounce logic is also available. Event sensing is used to selectively sense high-to-low level, or low-to-high level transitions on the input lines at the range thresholds of 4V ("-1" units), 16V ("-2" units), and 38V ("-3" units). Event polarities may be defined as positive or negative for individual nibbles (groups of 4 input lines, or half ports). Interrupts may also be triggered by events. The optional debounce logic can act as a filter to "glitches" or transients present on received signals.

Because the ASIC used by this model is capable of I/O, while the module is intended for input only, individual input ports should be masked from writes to the port. Otherwise, writing a "1" to an input line will cause the input to always read 0 (until a "0" is written or a reset occurs).

The Enhanced Mode is entered by writing four unique bytes to the Standard Mode Port 7 register, in consecutive order, without doing any reads or writes to any other port and with interrupts disabled. The data pattern to be written is 07H, 0DH, 06H, and 12H, and this must be written immediately after reset or power-up.

In Enhanced Mode, there are three groups (or banks) of eight registers or ports. The first group, bank 0, provides register functionality similar to Standard Mode (input level monitoring). The second group, bank 1, provides monitor and control of the event sense inputs. The third group, bank 2, is used to configure the debounce circuitry for each input while in the Enhanced Mode.

Event Sensing

The IP440 has edge-programmable event sense logic built-in for all 32 input lines, IN00 through IN31. Event sensing may be configured to generate an interrupt to the carrier, or to merely reflect the interrupt internally. Event sensing is enabled in Enhanced Mode only and inputs can be set to detect positive or negative events, on a nibble-by-nibble (group of 4 input lines) basis. The event sensing is enabled on an individual channel basis. You can combine event sensing with the built-in debounce control circuitry to obtain "glitch-free" edge detection of incoming signals.

To program events, determine which input lines are to have events enabled and which polarity is to be detected, high-to-low level transitions (negative) or low-to-high level transitions (positive). Set each half-port (nibble) to the desired polarity, then enable each of the event inputs to be detected. Optionally, if interrupt requests are desired, load the interrupt vector register and enable the interrupt request line. Note that all event inputs are reset, set to positive events, and disabled after a power-up or software reset has occurred.

Change-Of-State Detection

Change-of-State signal detection requires that both a high-to-low and low-to-high signal transition be detected. On the IP440, if change-of-state detection for an input signal is desired, two channels connected to the same input signal would be required--one sensing positive transitions, one sensing negative transitions. Since channel polarity is programmable on a nibble basis (group of four), the first nibble of a port could be configured for low-to-high transitions, the second nibble for high-to-low transitions. As such, up to 16 change-of-state detectors may be configured.

Debounce Control

Debounce control is built into the on-board digital ASIC employed by the IP440 and is enabled in the Enhanced Mode only. With debounce, an incoming signal must be stable for the entire debounce time before it is recognized as a valid input or event at the ASIC input. Note that the debounce time applies at the ASIC input and does not include the optocoupler delay. You can combine debounce with event sensing to obtain "glitch-free" edge detection of incoming signals for all 32 channels. That is, the debounce circuitry will help filter out "glitches" or transients that can occur on received signals, for error-free edge detection and increased noise immunity.

The debounce circuitry uses the 8MHz carrier clock to derive the debounce times (see the Debounce Clock Select register to enable the 8MHz clock to be used). With the 8MHz carrier clock, a debounce value of 3-4us, 48-64us, 0.75-1ms, or 6-8ms may be selected (see the Debounce Duration Register). As such, an incoming ASIC signal must be stable for the debounce time before it is recognized as a valid input or event.

Upon initialization of the debounce circuitry, be sure to delay at least the programmed debounce time before reading any of the input ports or event signals to ensure that the input data is valid prior to being used by the software.

Interrupt Generation

This model provides control for generation of interrupts on positive or negative events, for all 32 channels. Interrupts are only generated in the Enhanced Mode for event channels when enabled via the Event Sense/Status Register. Writing 0 to the corresponding event sense bit in the Event Sense/Status Register will clear the event sense flip/flop. Successive interrupts will only occur if the event channel has been reset by writing a 1 to the corresponding event sense bit in the Event Sense/Status Register (after writing 0 to clear the event sense flip/flop). Interrupts may be reflected internally and reported by polling the module, or optionally reported to the carrier by enabling control of the Interrupt Request line (IntReq0). Control of this line is initiated via Bit 0 of the Interrupt Enable Register (IER).

After pulling the IntReq0 line low and in response to an Interrupt Select cycle, the module will read (serve) the 8-bit interrupt vector stored in the Interrupt Vector Register. The IntReq0 line will be released as soon as the conditions generating the interrupt have been cleared or return to normal, and the event sense flip/flop has been cleared by writing 0 to the corresponding bit position of the Event Sense Status Register, or until the Interrupt Enable Register bit is cleared. Zero wait states are required to complete an interrupt select cycle.

Note that the state of the inputs (on/off) is determined by reading the corresponding port address while in bank 0 of the Enhanced Mode. However, the event sense status can only be read by reading the corresponding port address while in bank 1 of the Enhanced Mode. Remember, the event sense status is a flag that is raised when a specific positive or negative transition has occurred for a given input point, while the state refers to its current level.

Note that the Interrupt Enable Register and Interrupt Vector Register are cleared following a power-up or bus initiated software reset, but not a software reset initiated via writing a one to bit 1 of the Interrupt Enable Register. Keep this in mind when you wish to preserve the information in these two registers following a reset.

Programming Example

The following example outlines the steps necessary to configure the IP440 for Enhanced Mode operation, to setup event-generated interrupts, configure debounce, and read and write inputs. It is assumed that the module has been reset and no prior (non-default) configuration exists.

For this example, we will configure port 0 input points as a four-channel change-of-state detector. For change-of-state detection, both positive and negative polarities must be sensed and thus, two channels are required to detect a change-of-state on a single input signal. IN00-IN03 will be used to detect positive events (low-to-high transitions), IN04-IN07 will be used to detect negative events (high-to-low transitions). IN00 and IN04 will be tied to the first input signal, IN01 & IN05 to the second, IN02 & IN06 to the third, and IN03 & IN07 to the fourth. Any change-of-state detected on these input signal lines will cause an interrupt to be generated.

1. After power-up or reset, the module is always placed in the Standard Operating Mode. To switch to the Enhanced Mode, execute four consecutive write cycles to port 7 with the following data: 07H first, followed by 0DH, followed by 06H, then 12H.

At this point, you are in Enhanced Mode bank 0. Port 7 would now be used to access register banks 1 & 2.

2. Write 80H to the port 7 address to select register bank 2 where debounce will be configured for our port 0 input channels.

At this point, you are in Enhanced Mode Bank 2 where access to the debounce configuration registers is obtained.

3. We need to enable the 8MHz system clock to generate our debounce time. By default, the debounce clock is not enabled. Select the 8MHz system clock as the debounce clock by writing 01H to the port 3 address of this bank (Debounce Clock Select Register).
4. The default debounce duration is 3-4us with the 8MHz clock enabled in step 3. This time applies to the ASIC input signal and does not include optocoupler delay. Write 01H to the port 1 address of this bank to select a 48-64us debounce time (Debounce Duration Register 0). An incoming signal must be stable for the entire debounce time before it will be recognized as a valid input transition by the ASIC.

Note that Debounce Duration Register 1 (port address 2) would be used to configure debounce durations for ports 4 & 5. Since ports 4 & 5 are not used by this model, Debounce Duration Register 1 has no effect.

5. Enable the debounce circuitry for port 0 inputs by setting bit 0 of the Debounce Control Register. Write 01H to the Port 0 address of this bank (Debounce Control Register).

If the module had been configured earlier, you would first read this register to check the existing settings of debounce enable for the other ports of this module with the intent of preserving their configuration by adjusting the value written above.

6. Write 40H to the port 7 address to select register bank 1 where the event polarity requirements of our application will be configured.

At this point, you are in Enhanced Mode Bank 1 where access to the event polarity/status registers is obtained.

7. For change-of-state detection, both positive and negative polarities must be sensed. As such, two channels are required to detect a change-of-state on a single input signal. For our example, IN00-IN03 will be used to detect positive events (low-to-high transitions), IN04-IN07 will be used to detect negative events (high-to-low transitions). Write 02H to the port 6 address to set IN00-IN03 to positive edge detection, and IN04-IN07 to negative edge detection.

Note that this port address has a dual function depending on whether a read or write is being executed. As such, if the current polarity configuration for the other ports must be preserved, then it must be remembered since it cannot be read back.

8. To enable event sensing for the port 0 input points, write FFH to the Event Sense Status Register for port 0 input points at the port 0 address in this bank.

Note that writing a 1 to a bit position enables the event sense detector, while writing a 0 clears the event sensed without enabling further event sensing.

9. Write 00H to the port 7 address to select register bank 0 where the port 0 input channels may be write-masked.

Note that the port 7 address bank selection only operates from bits 6 & 7 of this register. Likewise, this register has a dual function depending on whether a read or write is executed. As such, the polarity settings cannot be read back and must be remembered if they are to be preserved for successive writes.

At this point, you are in Enhanced Mode Bank 0 where access to the write-mask register is obtained.

10. For our example, port 0 input points are to be used for inputs only and writes to this port should be masked to prevent the possibility of data contention between the built-in output circuitry and the devices driving these inputs. Write 01H to the port 7 address to mask writes to port 0.

11. Read 01H from the port 7 address to verify bank 0 access (bits 6 & 7 are 0) and port 0 write masking (bit 0 is 1).

12. (OPTIONAL) Write your interrupt vector to the Interrupt Vector Register Address (Note that this register operates independent of the current bank since it does not reside at any of the bank addresses).

13. (OPTIONAL) Write 01H to the Interrupt Enable Register (IER) address location to enable IP control of the IP Interrupt Request 0 line (IntReq0).

When a change-of-state is detected, IntReq0 will be pulled low (if the event sense detection circuitry has been enabled and IER bit 0=1). In response, the host will execute an Interrupt Select cycle and the contents of the Interrupt Vector Register will be provided. To enable further interrupts for an event that has already occurred at an input point, the Event Sense Status Register must be written with a 1 to reenable event sensing for subsequent events (only after first writing 0 to the corresponding bit position to clear the event sense flip/flop).

Note that the state of the inputs (on/off) can be determined by reading the corresponding port address while in bank 0 of the Enhanced Mode. However, the event sense status can only be determined by reading the corresponding port address while in bank 1 of the Enhanced Mode. Remember, the event sense status is a flag that is raised when a specific positive or negative transition has occurred for a given input point, while the state refers to its current level.

4.0 THEORY OF OPERATION

This section provides a description of the basic functionality of the circuitry used on the board. Refer to the Drawing 4501-594 as you review this material.

IP440 OPERATION

The IP440 is built around a digital ASIC chip that provides I/O interface and configuration functions. This chip performs monitor and control functions of up to 48 open-drain outputs (only 32 are used by this model). The ASIC also provides debounce control and event sensing functions.

A programmable logic device is installed on board to provide the control interface necessary to operate the module, plus the IP identification (IDPROM) memory required per the IP specification. The Interrupt Enable Register, Software Reset Control, and Interrupt Vector Register are also implemented through the PLD.

Individual optocouplers for each channel provide isolation for the Model IP440. Channels are isolated from each other in groups of 8. There are 8 channels to a group or port. Because the input lines of a single port share a common connection, then individual inputs are not isolated from each other within the same port. However, separate port commons are provided to facilitate port-to-port isolation.

Input optocouplers of this device are bipolar and accept voltages in three ranges: \pm (4-18V), \pm (16-40V), and \pm (38-60V), DC or AC peak. The optocouplers connect directly to a digital ASIC I/O controller that provides the I/O read/write functionality, interrupt handling, and debounce control.

LOGIC/POWER INTERFACE

The logic interface to the carrier board is made through connector P1 (refer to Table 2.2). P1 also provides +5V to power the module (the \pm 12V lines are not used). Not all of the IP logic P1 pin functions are used.

A programmable logic device installed on the IP Module provides the control signals required to operate the board. It decodes the selected addresses in the I/O, Interrupt, and ID spaces and produces the chip selects, control signals, and timing required by the control registers, as well as, the acknowledgement signal required by the carrier board per the IP specification. It also stores the interrupt vector and controls whether event interrupts will drive the carrier board interrupt request line.

The ID PROM (read only) is implemented in the PLD installed on the IP module and provides the identification for the individual module per the IP specification. The ID PROM & configuration and control registers are all accessed through an 8-bit data bus interface to the carrier board.

5.0 SERVICE AND REPAIR

SERVICE AND REPAIR ASSISTANCE

Surface-Mounted Technology (SMT) boards are generally difficult to repair. It is highly recommended that a non-functioning board be returned to Acromag for repair. The board can be easily damaged unless special SMT repair and service tools are used. Further, Acromag has automated test equipment that thoroughly checks the performance of each board. When a board is first produced and when any repair is made, it is tested, placed in a burn-in room at elevated temperature, and retested before shipment.

Please refer to Acromag's Service Policy Bulletin or contact Acromag for complete details on how to obtain parts and repair.

PRELIMINARY SERVICE PROCEDURE

Before beginning repair, be sure that all of the procedures in Section 2, Preparation For Use, have been followed. Also, refer to the documentation of your carrier board to verify that it is correctly configured. Replacement of the module with one that is known to work correctly is a good technique to isolate a faulty module.

CAUTION: POWER MUST BE TURNED OFF BEFORE REMOVING OR INSERTING BOARDS

Acromag's Application Engineers can provide further technical assistance if required. When needed, complete repair services are also available from Acromag.

6.0 SPECIFICATIONS

GENERAL SPECIFICATIONS

Operating Temperature.....	0 to +70°C. -40 to +85°C (E Versions)
Relative Humidity.....	5-95% non-condensing.
Storage Temperature.....	-55°C to +125°C.
Physical Configuration.....	Single Industrial I/O Pack Module.
Length.....	3.880 inches (98.5 mm).
Width.....	1.780 inches (45.2 mm).
Board Thickness.....	0.062 inches (1.59 mm).
Max Component Height.....	0.314 inches (7.97 mm).
Connectors:	
P1 & P2	IP logic (P1) & field (P2) interface connectors -.50-pin female receptacle header (AMP 173279-3 or equivalent).
Power:	
+5 Volts (\pm 5%).....	90mA, Typical (all inputs low); 120mA, Typical (all inputs high); 160mA, Maximum.
\pm 12 Volts (\pm 5%) from P1.....	0mA Maximum (Not Used).
Isolation.....	Logic and field connections are optically isolated (see INPUT specifications). Individual ports are also isolated from each other. However, input lines of individual ports share a common connection and are not isolated from each other. Separate port commons are provided to facilitate port-to-port isolation. Logic and field lines are isolated from each other for voltages up to 250VAC, or 354V DC on a continuous basis (unit will withstand a 1500V AC dielectric strength test for one minute without breakdown). This complies with test requirements outlined in ANSI/ISA-S82.01-1988 for the voltage rating specified.
Isolation Spacing.....	Printed circuit board minimum isolation spacings are as follows: Port-to-Logic - 0.025" Minimum; Port-to-Port - 0.015" Minimum. These clearances apply to inner layer foil spacings (outer layer foil spacings are greater).
Resistance to RFI.....	No data upsets occur for field strengths up to 10V per meter at 27MHz, 151MHz, & 460MHz per SAMA PMC 33.1 test procedures.
Resistance to EMI.....	Unit has been tested with no data upsets under the influence of EMI from switching solenoids, commutator motors, and drill motors.
ESD Protection.....	Field input lines are protected from ESD voltages to \pm 4KV, typical.

INPUTS

Input Channel Configuration.....32 Optically isolated bipolar inputs. For DC or AC voltage applications within specified range limits.

Isolation Medium.....Photo-transistor optocoupler, Siemens SFH628A-4 or equivalent. UL & VDE rated for isolation voltage applications up to 400V DC or AC rms (optocoupler only).

Bipolar Input Voltage Range.....AC or DC Volts peak, according to model number: $\pm 4V$ to $\pm 18V$ (Model IP440-1); $\pm 16V$ to $\pm 40V$ (Model IP440-2); $\pm 38V$ to $\pm 60V$ (Model IP440-3). Range is determined by value of the input current limiting SIP resistors installed on the module (R5, R6, R7, R8).

Input Threshold.....Input Low-to-High threshold is $\pm 4V$ Maximum, $\pm 2.0V$ Typical (IP440-1); $\pm 16V$ Maximum, $\pm 6.4V$ Typical (IP440-2); or $\pm 38V$ Maximum, $\pm 12.9V$ Typical (IP440-3). The IP440-1 model may be used to interface with open-drain TTL outputs when used with an appropriate pullup to +5V (see Drawing 4501-603).

Input Hysteresis.....80mV Typical.

Input Capacitance.....45pF Typical.

Turn-On Time.....Measured to the point of positive event interrupt detection (IntReq0 pulled low) - 15us Typical (25°C) for a 0 to threshold value input step. This time decreases as the magnitude of the step is increased above the threshold.

Turn-Off Time.....Measured to the point of negative event interrupt detection (IntReq0 pulled low) - 35us Typical (25°C) for a threshold to 0V input step. This time increases as the magnitude of the step value is increased from the threshold.

Input Debounce.....Each input includes debounce circuitry with variable debounce times. Debounce times are programmable and derived from the 8MHz system clock, in combination with the debounce duration register value. Debounce times are applied at the ASIC input and do not include optocoupler delay time. Debounce values of 3-4us, 48-64us, 0.75-1ms, and 6-8ms may be configured. Note that the debounce clock must be enabled via the Debounce Select register to utilize debounce.

Interrupts.....32 channels of interrupts may be configured for high-to-low, low-to-high, and change-of-state (two inputs required) event types.

Forward Voltage Drop.....1.1V Typical, 1.5V Maximum (Diode) + I*R. Series input current-limiting resistors are 2.2K (IP440-1), 12K (IP440-2), or 27K (IP440-3) and installed on board.

Input Current.....Varies according to model number and input signal voltage level. For Model IP440-1, the current is computed by dividing the signal level minus 1.5V, by its current limiting resistor (2200Ω for IP440-1, 12000Ω for IP440-2, and 27000Ω for IP440-3).

INDUSTRIAL I/O PACK COMPLIANCE

Specification.....This module meets or exceeds all written Industrial I/O Pack specifications per revision 0.7.1.

Electrical/Mechanical Interface.....Single-Size IP Module.

IP Data Transfer Cycle Types Supported:

- Input/Output (IOSel*).....D16 or D08 least significant byte read/write of port data.
- ID Read (IDSel*).....32 x 8 ID PROM read on D0..D7.
- Interrupt Select (INTSel*).....8-bit word (D08) read of Interrupt Vector Register contents.

Access Times (8MHz Clock):

- All Read/Write Cycles.....0 wait states (250ns cycle).

APPENDIX

**CABLE: MODEL 5025-550-x (Non-Shielded)
MODEL 5025-551-x (Shielded)**

Type: Flat Ribbon Cable, 50-wires (female connectors at both ends). The '-x' suffix designates the length in feet (12 feet maximum). Choose shielded or unshielded cable according to model number. The unshielded cable is recommended for digital I/O, while the shielded cable is recommended for optimum performance with precision analog I/O applications.

Application: Used to connect a Model 5025-552 termination panel to the AVME9630/9660 non-intelligent carrier board A-D connectors (both have 50-pin connectors).

Length: Last field of part number designates length in feet (user-specified, 12 feet maximum). It is recommended that this length be kept to a minimum to reduce noise and power loss.

Cable: 50-wire flat ribbon cable, 28 gage. Non-Shielded cable model uses Acromag Part 2002-211 (3M Type C3365/50 or equivalent). Shielded cable model uses Acromag Part 2002-261 (3M Type 3476/50 or equivalent).

Headers (Both Ends): 50-pin female header with strain relief. *Header* - Acromag Part 1004-512 (3M Type 3425-6600 or equivalent). *Strain Relief* - Acromag Part 1004-534 (3M Type 3448-3050 or equivalent).

Keying: Headers at both ends have polarizing key to prevent improper installation.

Schematic and Physical Attributes: For Non-Shielded cable model, see Drawing 4501-462. For Shielded cable model, see Drawing 4501-463.

Shipping Weight: 1.0 pound (0.5Kg) packaged.

CABLE: MODEL 5029-900

Type: Model 5029-900 APC8600 High-Density Cable: A 36-inch long interface cable that mates the high-density (25mil pitch) 50-pin I/O connectors of the APC8600 PC/AT ISAbus carrier board, to the high density connectors on the APC8600 Termination Panels (described below).

Application: Used with the APC8600 PC carrier and termination panel. It mates the high-density (25mil pitch) 50-pin I/O connectors of the APC8600 PC/AT ISAbus carrier board, to the high density connectors on the APC8600 Termination Panel (described below).

Length: 36-inches

Cable: 50-wire flat ribbon cable, 28 gage, Non-Shielded, T&B/Ansley Part 135-050 or equivalent.

Headers: 50-pin, high-density, 25-mil pitch, female header. Header-T&B Ansley Part 311-050302 or equivalent.

Keying: Headers at both ends have polarizing key to prevent improper installation.

Shipping Weight: 1.0 pound (0.5Kg) packaged.

TERMINATION PANEL: MODEL 5025-552

Type: Termination Panel For AVME9630/9660 Boards

Application: To connect field I/O signals to the Industrial I/O Pack (IP). *Termination Panel:* Acromag Part 4001-040 (Phoenix Contact Type FLKM 50). The 5025-552 termination panel facilitates the connection of up to 50 field I/O signals and connects to the AVME9630/9660 3U/6U non-intelligent carrier boards (A-D connectors only) via a flat ribbon cable (Model 5025-550-x or 5025-551-x). The A-D connectors on the carrier board connect the field I/O signals to the P2 connector on each of the Industrial I/O Pack modules. Field signals are accessed via screw terminal strips. The terminal strip markings on the termination panel (1-50) correspond to P2 (pins 1-50) on the Industrial I/O Pack (IP). Each Industrial I/O Pack (IP) has its own unique P2 pin assignments. Refer to the IP module manual for correct wiring connections to the termination panel.

Schematic and Physical Attributes: See Drawing 4501-464.

Field Wiring: 50-position terminal blocks with screw clamps. Wire range 12 to 26 AWG.

Connections to AVME9630/9660: P1, 50-pin male header with strain relief ejectors. Use Acromag 5025-550-x or 5025-551-x cable to connect panel to VME board. Keep cable as short as possible to reduce noise and power loss.

Mounting: Termination panel is snapped on the DIN mounting rail.

Printed Circuit Board: Military grade FR-4 epoxy glass circuit board, 0.063 inches thick.

Operating Temperature: -40°C to +100°C.

Storage Temperature: -40°C to +100°C.

Shipping Weight: 1.25 pounds (0.6kg) packaged.

TERMINATION PANEL: MODEL 5029-910

Type: Screw-Terminal Termination Panel For Acromag APC8600 PC/AT ISAbus Carrier Boards.

Application: This panel converts the high-density ribbon-cable connectors coming from the APC8600 carrier board (Acromag cable Model 5029-900) to screw terminals, for direct-wired interfaces. This panel facilitates the connection of up to 50 field I/O signals and connects to the APC8600 PC/AT ISAbus carrier board via high-density (25-mil pitch) flat ribbon cable and connectors (see cable Model 5029-900). The A & B connectors on the carrier board connect the field I/O signals to the P2 connector on each of the Industrial I/O Pack modules. Field signals are accessed via screw terminal strips. Each Industrial I/O Pack (IP) has its own unique P2 pin assignments. Refer to the IP module manual for correct wiring connections to the termination panel.

Field Wiring: 50-position terminal blocks with screw clamps. Wire range 12 to 26 AWG.

Connections to APC8600: P1, 50-pin, high-density male header with strain relief.

Mounting: Termination Panel includes mounting holes.

Printed Circuit Board: Military grade FR-4 epoxy glass circuit board, 0.063 inches thick.

Operating Temperature: -40°C. to +85°C.

Storage Temperature: -55°C to +125°C.

Shipping Weight: 1.25 pounds (0.6kg) packaged.

TRANSITION MODULE: MODEL TRANS-GP

Type: Transition module for AVME9630/9660 boards.

Application: To repeat field I/O signals of IP modules A through D for rear exit from VME card cages. This module is available for use in card cages which provide rear exit for I/O connections via transition modules (transition modules can only be used in card cages specifically designed for them). It is a double-height (6U), single-slot module with front panel hardware adhering to the VMEbus mechanical dimensions, except for shorter printed circuit board depth. Connects to Acromag termination panel 5025-552 from the rear of the card cage, and to AVME9630/9660 boards within card cage, via flat 50-pin ribbon cable (cable Model 5025-550-X or 5025-551-X).

Schematic and Physical Attributes: See Drawing 4501-465.

Field Wiring: 100-pin header (male) connectors (3M 3433-D303 or equivalent) employing long ejector latches and 30 micron gold in the mating area (per MIL-G-45204, Type II, Grade C).

Connects to Acromag termination panel 5025-552 from the rear of the card cage via flat 50-pin ribbon cable (cable Model 5025-550-X or 5025-551-X).

Connections to AVME9630/9660: 50-pin header (male) connectors (3M 3433-1302 or equivalent) employing long ejector latches and 30 micron gold in the mating area (per MIL-G-45204, Type II, Grade C). Connects to AVME9630/9660 boards within the card cage via flat 50-pin ribbon cable (cable Model 5025-550-X or 5025-551-X).

Mounting: Transition module is inserted into a 6U-size, single-width slot at the rear of the VMEbus card cage.

Printed Circuit Board: Six-layer, military-grade FR-4 epoxy glass circuit board, 0.063 inches thick.

Operating Temperature: -40°C to +85°C.

Storage Temperature: -55°C to +105°C.

Shipping Weight: 1.25 pounds (0.6Kg) packaged.

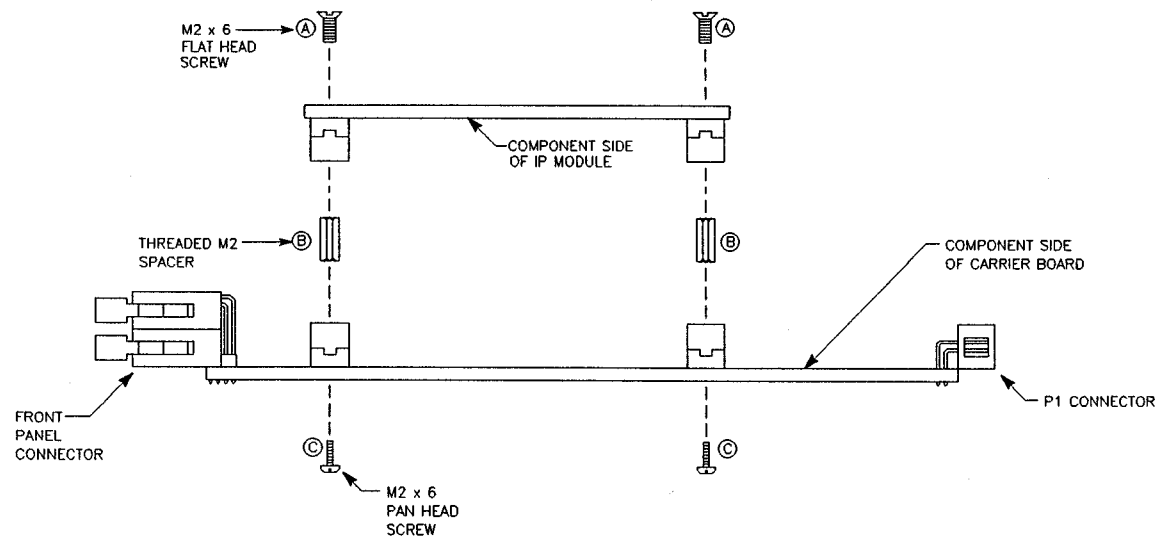

ASSEMBLY PROCEDURE:

1. THREADED SPACERS ARE PROVIDED IN TWO DIFFERENT LENGTHS. THE SHORTER LENGTH IS FOR USE WITH AVME 9630/9660 CARRIER BOARDS (SHOWN). CHECK YOUR CARRIER BOARD TO DETERMINE ITS REQUIREMENTS. MOUNTING HARDWARE PROVIDED MAY NOT BE COMPATIBLE WITH ALL TYPES OF CARRIER BOARDS.
2. INSERT FLAT HEAD SCREWS (ITEM A) THROUGH SOLDER SIDE OF IP MODULE AND INTO HEX SPACERS (ITEM B) AND TIGHTEN (4 PLACES) UNTIL HEX SPACER IS COMPLETELY SEATED.
3. CAREFULLY ALIGN IP MODULE TO CARRIER BOARD AND PRESS TOGETHER UNTIL CONNECTORS AND SPACERS ARE SEATED.
4. INSERT PAN HEAD SCREWS (ITEM C) THROUGH SOLDER SIDE OF CARRIER BOARD AND INTO HEX SPACERS (ITEM B) AND TIGHTEN (4 PLACES).

IP MODULE TO CARRIER BOARD MECHANICAL ASSEMBLY

Acromag WINDMILL MICH.		20 JUL 94	B	040811	TAV	JGV	BC
		21 DEC 93	A		TAV	JGV	BC
TITLE		DATE	REV	ENH	DR	ENG	CLP
IP MECHANICAL ASSEMBLY							
D	SERIES	IP	1 of 1	DOC NO.	4501-434	B	

FRONT EDGE OF CARRIER BOARD (AVME 9660 SHOWN)

NOTE: FRONT PANEL P2 PIN NUMBERS OF CARRIER BOARD NORMALLY CORRESPOND TO IPACK P2 PIN NUMBERS (1-50).

P2 FIELD CONNECTOR PIN ASSIGNMENTS

INPUT PIN	RIBBON CABLE/ P2 PIN NUMBER
IN00	01
IN01	02
IN02	03
IN03	04
NC	05
IN04	06
IN05	07
IN06	08
IN07	09
COM0	10
IN08	11
IN09	12
IN10	13
IN11	14
NC	15
IN12	16
IN13	17
IN14	18
IN15	19
COM1	20

INPUT PIN	RIBBON CABLE/ P2 PIN NUMBER
IN16	21
IN17	22
IN18	23
IN19	24
NC	25
IN20	26
IN21	27
IN22	28
IN23	29
COM2	30
IN24	31
IN25	32
IN26	33
IN27	34
NC	35
IN28	36
IN29	37
IN30	38
IN31	39
COM3	40
NC	41
NC	42
NC	43
NC	44
NC	45
NC	46
NC	47
NC	48
NC	49
NC	50

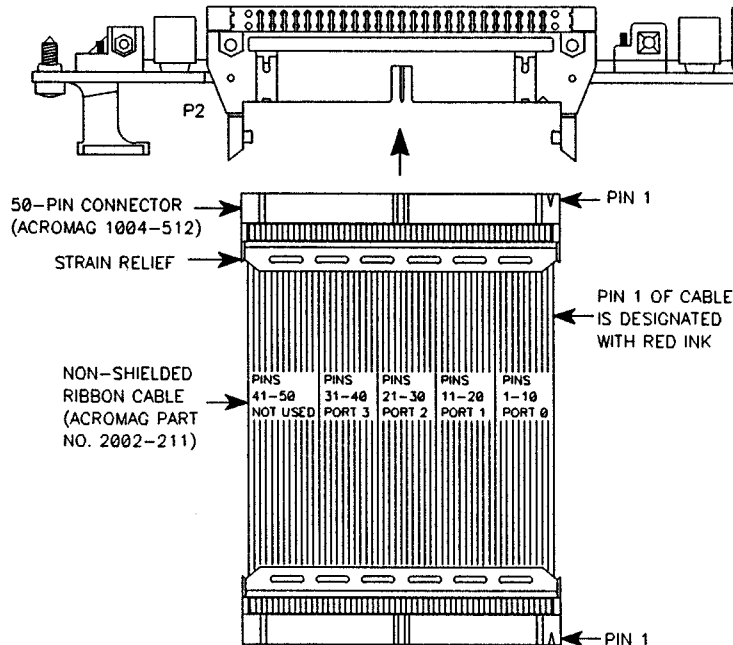

FIELD CONNECTION OPTIONS

THE MODEL 5025-552 TERMINATION PANEL MAY BE CONNECTED TO PROVIDE DIRECT (WIRED) SCREW TERMINAL HOOK-UP FOR THE FIELD SIDE I/O SIGNALS.

PIN ASSIGNMENTS ARE COMPATIBLE WITH INDUSTRY STANDARD DIGITAL I/O CARDS, SCREW TERMINATION PANELS, AND ELECTROMECHANICAL & SOLID STATE RELAY BOARDS (CONSULT FACTORY FOR RECOMMENDED PRODUCTS).

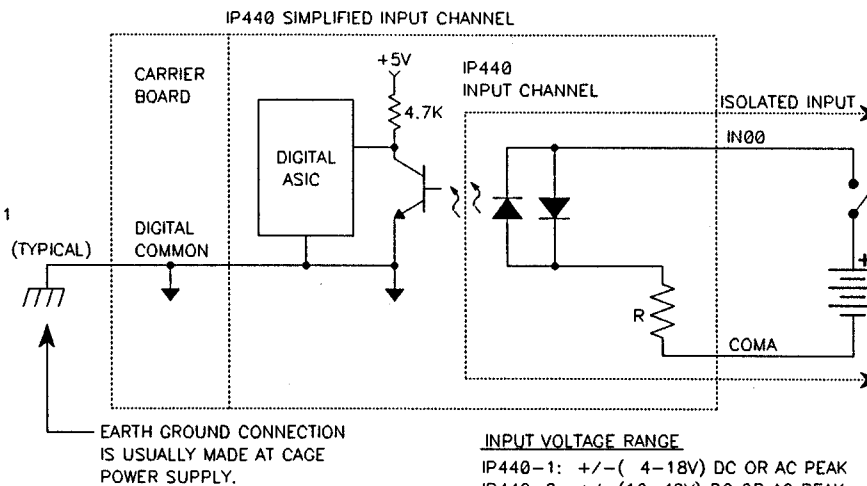

INPUT VOLTAGE RANGE

IP440-1: +/- (4-18V) DC OR AC PEAK
 IP440-2: +/- (16-40V) DC OR AC PEAK
 IP440-3: +/- (38-60V) DC OR AC PEAK

Acromag WILSON MICH.		12-DEC-95	A		BC	BC	BC
TITLE	IP440-X FIELD CONNECTIONS	DATE	REV	ECN	OR	END	CLP
D SERIES	IP440	1 of 1	DRG NO.	4501-593	A		

IP445 OUTPUT TO IP440 INPUT LOOPBACK CONNECTIONS

NOTE THAT FOR LOOPBACK PURPOSES, THE COMMON LINE OF AN IP440 PORT AND THE COMMON LINE OF AN IP445 PORT DO NOT NECESSARILY CONNECT TOGETHER.

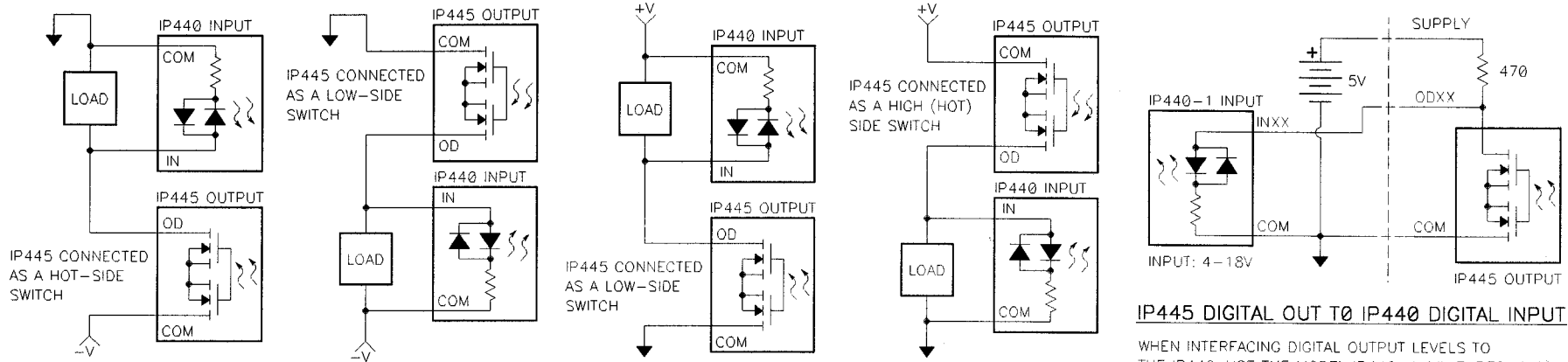

IP445 DIGITAL OUT TO IP440 DIGITAL INPUT

WHEN INTERFACING DIGITAL OUTPUT LEVELS TO THE IP440, USE THE MODEL IP440-1 (4V THRESHOLD) AND ADJUST THE EXTERNAL PULLUP VALUE ACCORDINGLY.

THE 4.7K PULLUP SUPPLIED WITH THE IP445 SHOULD BE REPLACED WITH 470 OHM PULLUPS.

WHEN INTERFACING THE IP445 TO A TYPICAL TTL INPUT DEVICE LIKE THE 74LS541, THE 4.7K PULLUPS SHOULD BE INSTALLED IN THEIR SOCKETS ON THE BOARD AND CONNECTED TO THE PART SUPPLY PIN.

P2 PINOUTS OF THE IP440 AND IP445 ARE DIRECTLY COMPATIBLE. HOWEVER, THE IP445 INCLUDES A PULLUP SUPPLY PIN FOR EACH PORT AT PIN 5 (PORT 0), PIN 15 (PORT 1), PIN 25 (PORT 2), AND PIN 35 (PORT 3). THESE PINS ARE NOT CONNECTED ON THE IP440.

IP440 INPUTS AND IP445 OUTPUTS ARE BIPOLAR AND MAY BE CONNECTED IN ANY DIRECTION WITH RESPECT TO PORT COMMON.

IP440 SIMPLIFIED INPUT CHANNEL

I/O INTERFACE

IP445 SIMPLIFIED OUTPUT CHANNEL

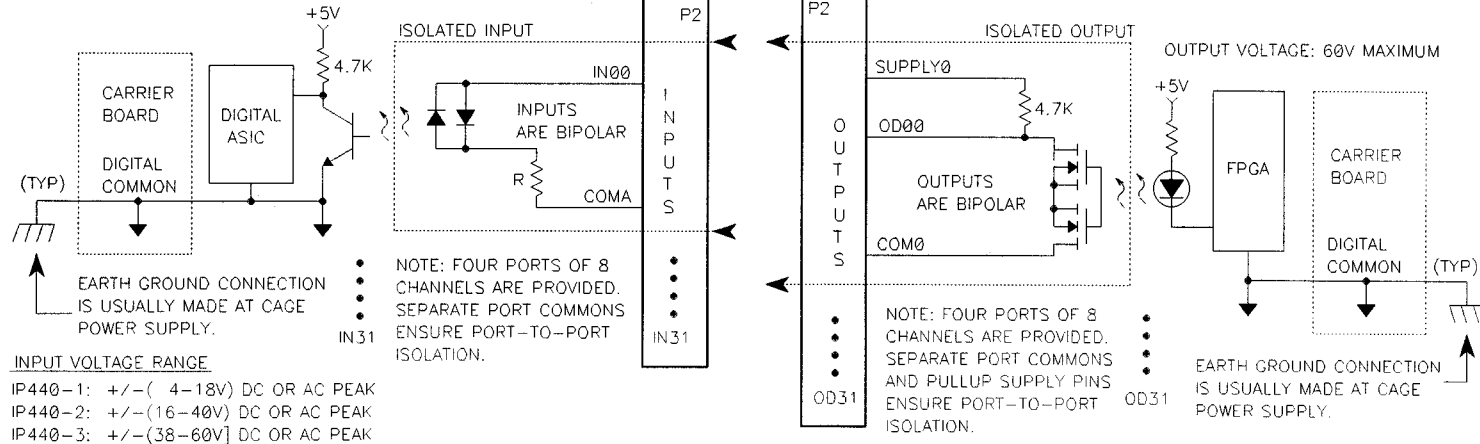

NOTE: FOUR PORTS OF 8 CHANNELS ARE PROVIDED. SEPARATE PORT COMMONS ENSURE PORT-TO-PORT ISOLATION.

NOTE: FOUR PORTS OF 8 CHANNELS ARE PROVIDED. SEPARATE PORT COMMONS AND PULLUP SUPPLY PINS ENSURE PORT-TO-PORT ISOLATION.

INPUT VOLTAGE RANGE

- IP440-1: +/- (4-18V) DC OR AC PEAK
- IP440-2: +/- (16-40V) DC OR AC PEAK
- IP440-3: +/- (38-60V) DC OR AC PEAK

OUTPUT VOLTAGE: 60V MAXIMUM

EARTH GROUND CONNECTION IS USUALLY MADE AT CAGE POWER SUPPLY.

Acromag		30-JAN-96	A	BC	BC	BC
WYOMING		DATE	REV	ECN	OR	ENG
TITLE IP440/445 LOOPBACK CONNECTIONS						
D	SERIES	IP440/445	1 of 1	DWG NO. 4501-603		

IP440 BLOCK DIAGRAM

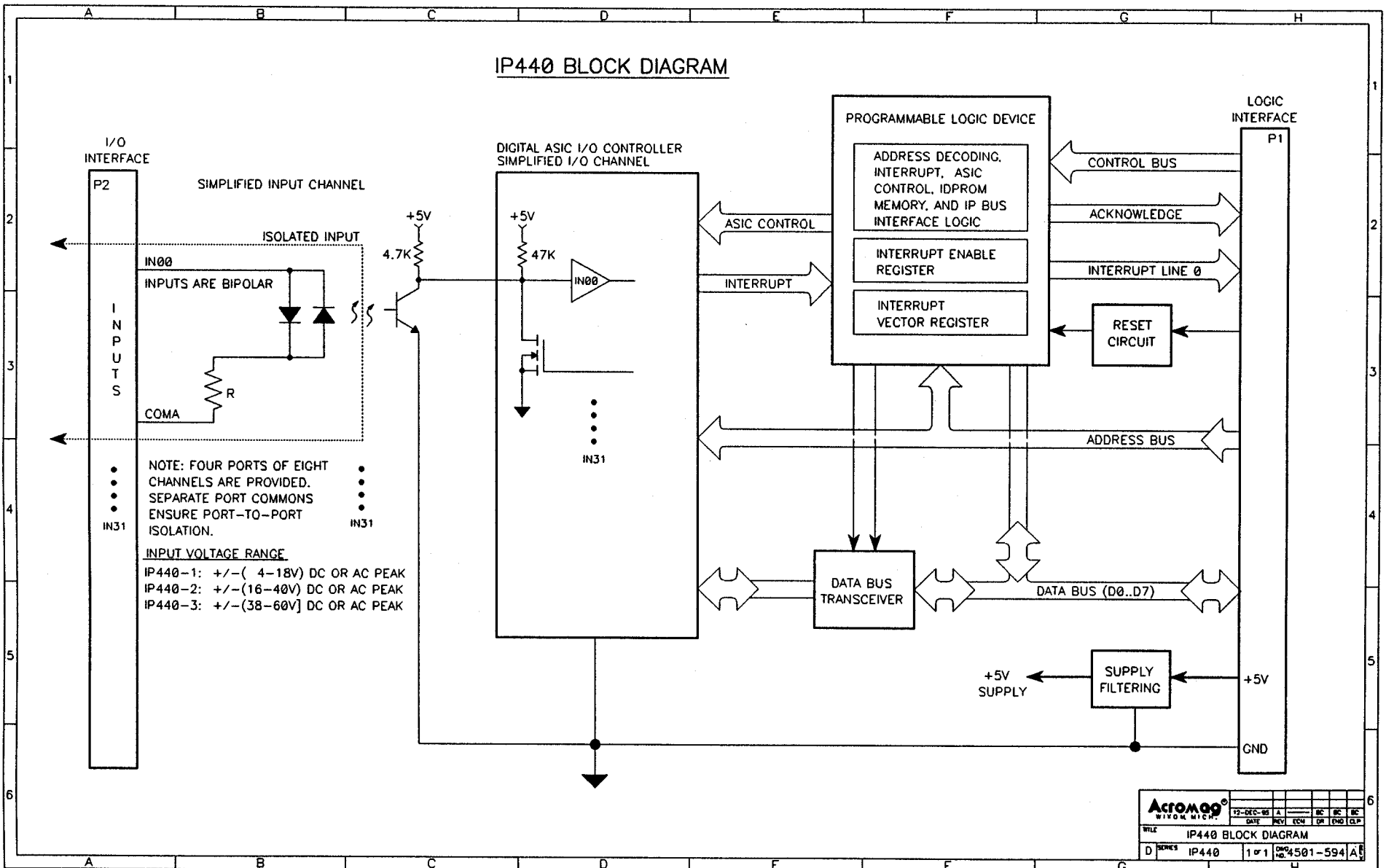

Acromag WILSON MICRO		12-DEC-95	A		BC	BC	BC
TITLE		DATE	REV	ECN	DR	END	CLP
IP440 BLOCK DIAGRAM							
D	SERIES	IP440	1	1	1	1	1
		OR	NO	4	501-594	A	E

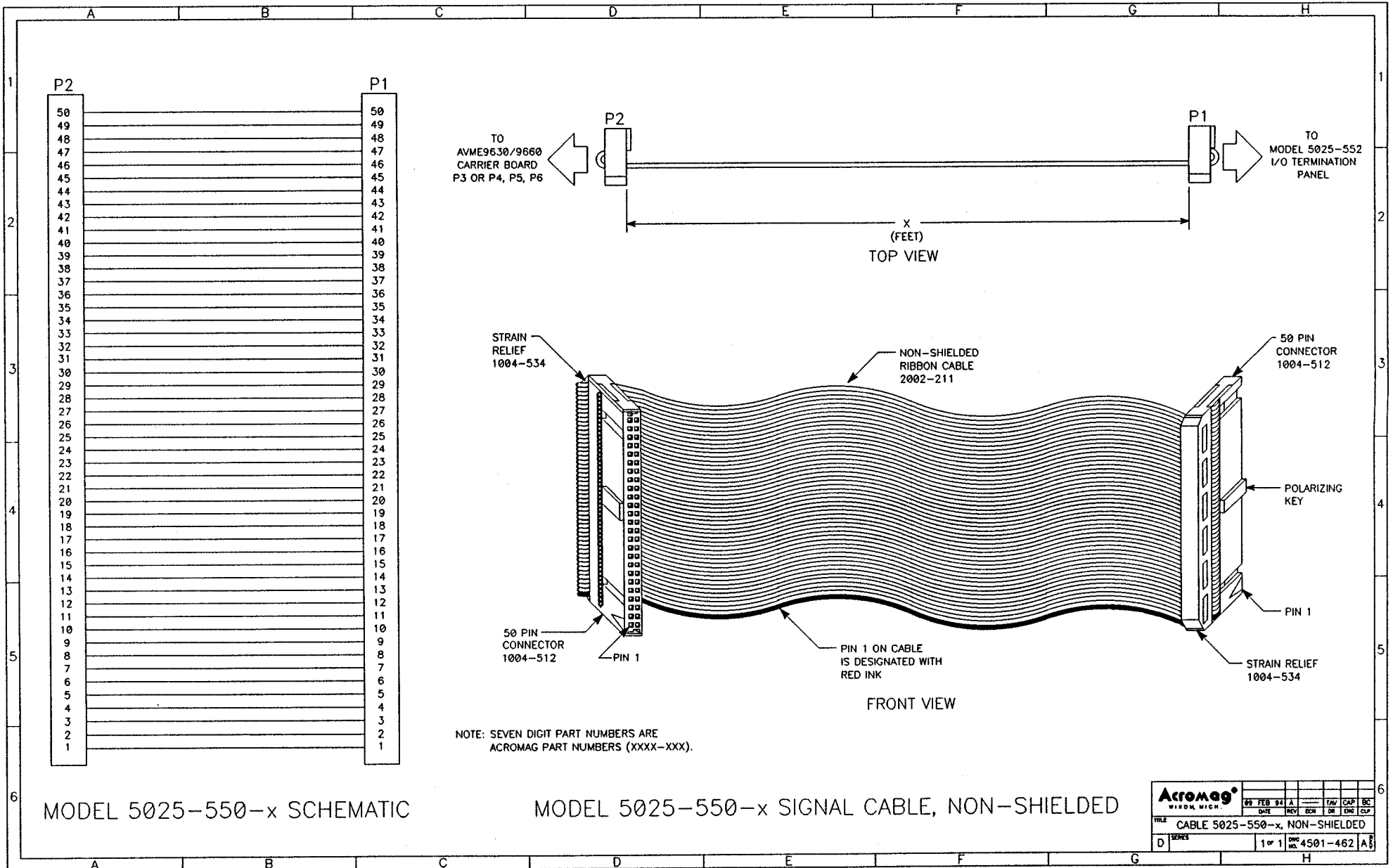

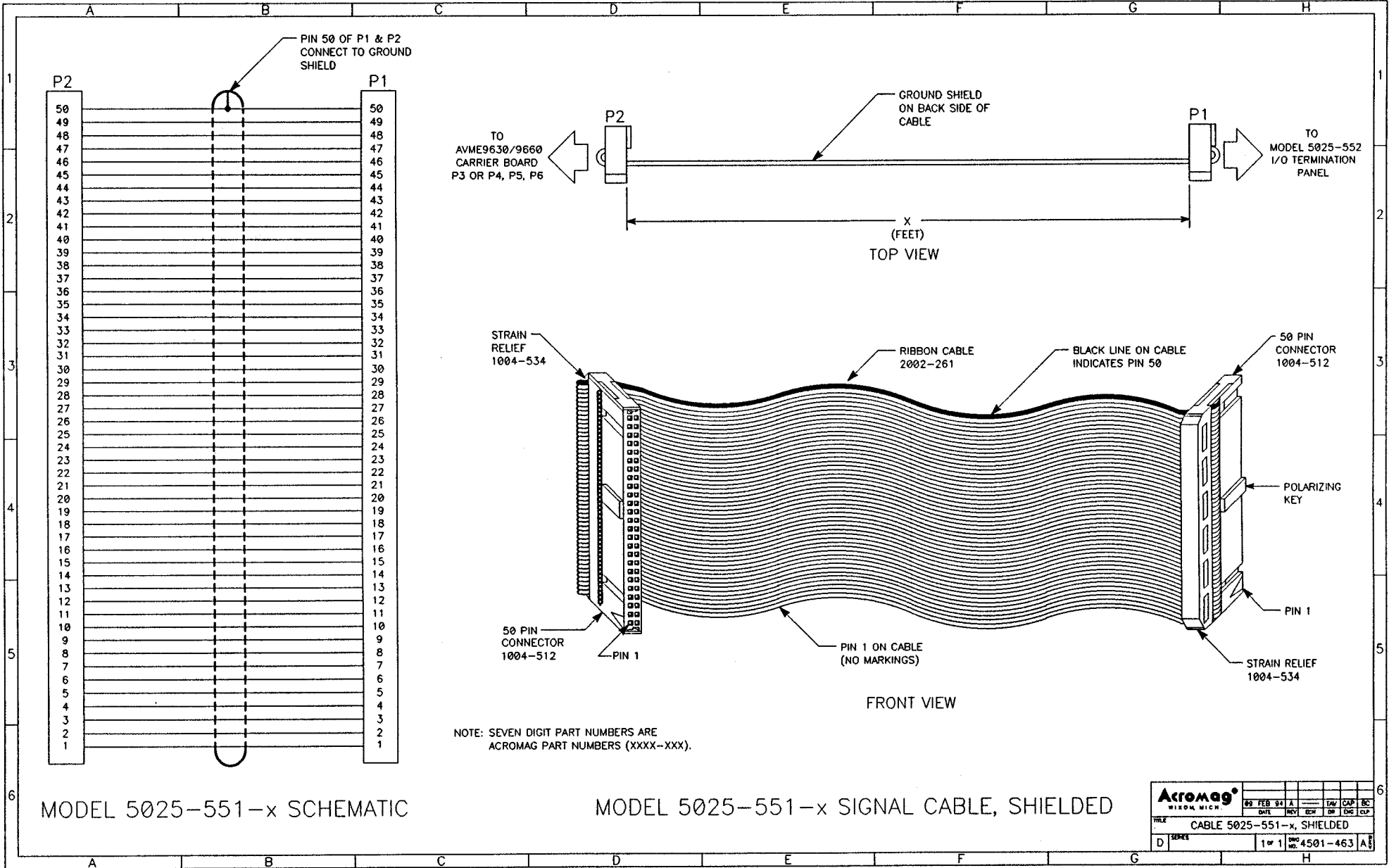

Acromag WILSON, MICH.		99	FEB	94	A						
DATE	REV	REP	IN	CAP	DC						
TITLE: CABLE 5025-551-x, SHIELDED											
D	REV	1	1	REV	NO.	4501-463	A				

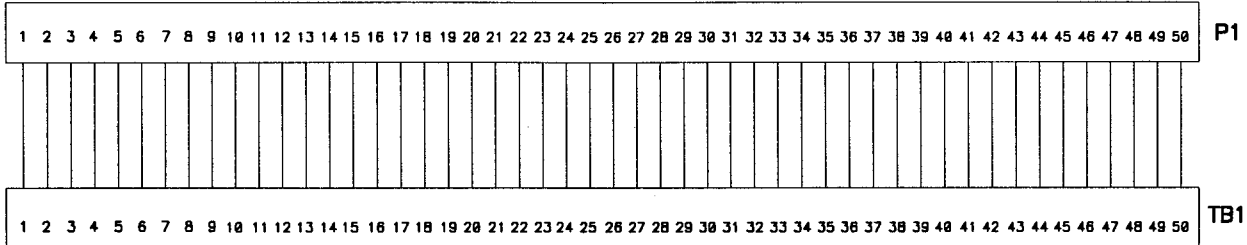

MODEL 5025-552 TERMINATION PANEL SCHEMATIC

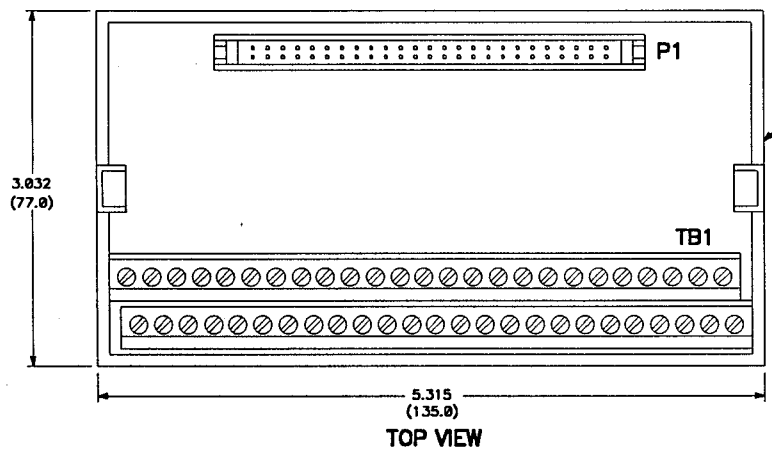

TERMINATION
PANEL
ACROMAG PART
NUMBER 4001-040.

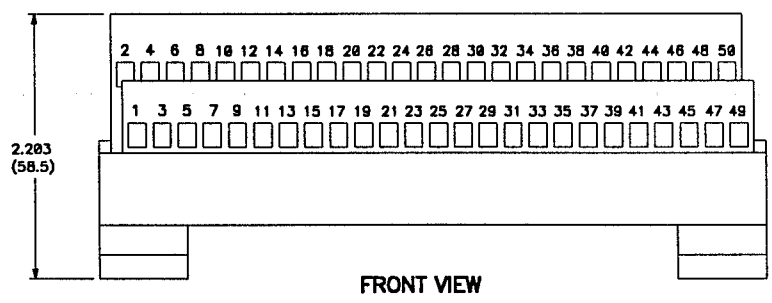
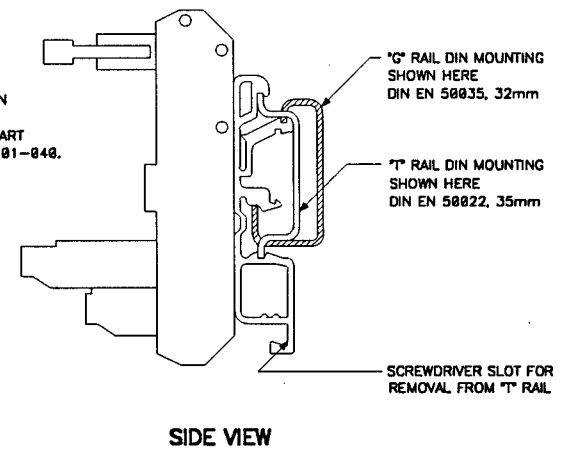

NOTES:
DIMENSIONS ARE IN INCHES (MILLIMETERS).
TOLERANCE: ±0.020 (±0.5).

MODEL 5025-552 TERMINATION PANEL

Acromag®						
09 FEB 94	A		TAV	CAP	BC	
WIXOM, MICH.	DATE	REV	ECN	DR	ENG	CLP
TITLE MODEL 5025-552 TERMINATION PANEL						
D	SERIES	1 of 1	DWG NO.	4501-464	A	REV

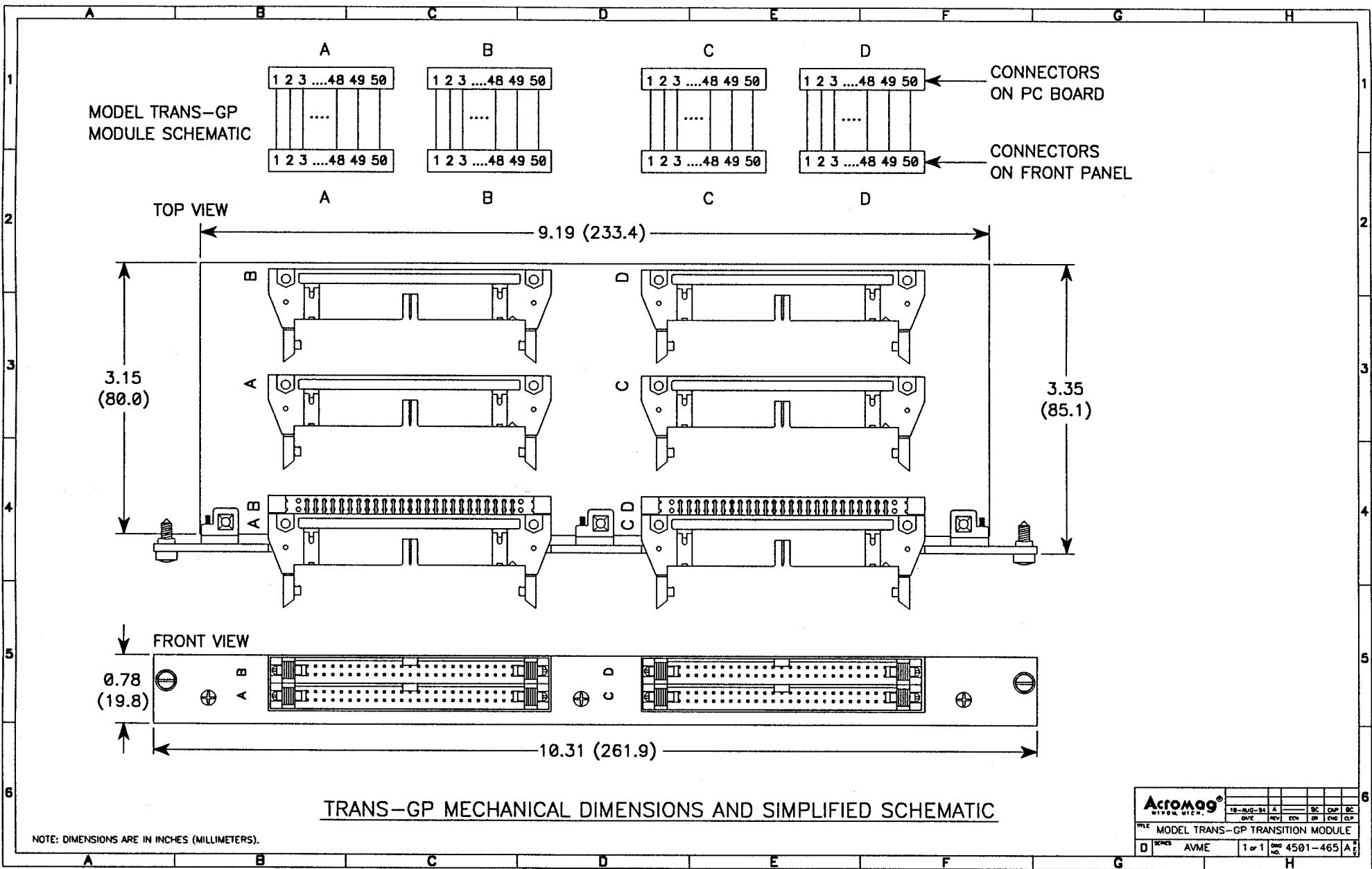

Acromag WILSON TECH.		18-820-34	A	DC	CP	DC
DATE	REV	EN	OR	END	CLP	
TITLE: MODEL TRANS-GP TRANSITION MODULE						
D	REVISED	AVME	1 of 1	DRW NO.	4501-465	A