



**Series IP231 Industrial I/O Pack
16-Bit High-Density Analog Output Board**

USER'S MANUAL

ACROMAG INCORPORATED

30765 South Wixom Road

P.O. BOX 437

Wixom, MI 48393-7037 U.S.A.

Tel: (248) 624-1541

Fax: (248) 624-9234

Copyright 2004 Acromag, Inc., Printed in the USA.
Data and specifications are subject to change without notice.

8500-757-A04L000

The information contained in this manual is subject to change without notice. Acromag, Inc. makes no warranty of any kind with regard to this material, including, but not limited to, the implied warranties of merchantability and fitness for a particular purpose. Further, Acromag, Inc. assumes no responsibility for any errors that may appear in this manual and makes no commitment to update, or keep current, the information contained in this manual. No part of this manual may be copied or reproduced in any form, without the prior written consent of Acromag, Inc.

Table of Contents	Page
1.0 GENERAL INFORMATION	2
KEY IP231 FEATURES.....	2
INDUSTRIAL I/O PACK INTERFACE FEATURES.....	3
SIGNAL INTERFACE PRODUCTS.....	3
INDUSTRIAL I/O PACK SOFTWARE LIBRARY.....	3
INDUSTRIAL I/O PACK OLE CONTROL SOFTWARE...	3
2.0 PREPARATION FOR USE	3
UNPACKING AND INSPECTION.....	3
CARD CAGE CONSIDERATIONS.....	3
BOARD CONFIGURATION.....	4
Default Hardware Configuration.....	4
Programmable Register Configuration.....	4
Analog Output Data Format.....	4
CONNECTORS.....	4
IP Field I/O Connector (P2).....	4
Analog Output Noise and Grounding Considerations....	5
IP Logic Interface Connector (P1).....	5
3.0 PROGRAMMING INFORMATION	5
ADDRESS MAPS.....	6
IP Identification PROM.....	6
DAC Channel Registers.....	6
Transparent Mode.....	7
Simultaneous Mode.....	7
Simultaneous Output Trigger.....	7
Channel Offset/Gain Error Coefficients.....	8
IP231 PROGRAMMING CONSIDERATIONS.....	8
Using the Transparent Mode.....	8
Using the Simultaneous Mode.....	8
USE OF CALIBRATION DATA.....	8
Uncalibrated Performance.....	8
Calibrated Performance.....	9
4.0 THEORY OF OPERATION	11
ANALOG OUTPUTS.....	11
LOGIC/POWER INTERFACE.....	11
5.0 SERVICE AND REPAIR	11
SERVICE AND REPAIR ASSISTANCE.....	11
PRELIMINARY SERVICE PROCEDURE.....	11
6.0 SPECIFICATIONS	12
GENERAL SPECIFICATIONS.....	12
ANALOG OUTPUTS.....	12
INDUSTRIAL I/O PACK COMPLIANCE.....	13
APPENDIX	14
CABLE: MODEL 5025-550.....	14
CABLE: MODEL 5025-551.....	14
TERMINATION PANEL: MODEL 5025-552.....	14
TRANSITION MODULE: MODEL TRANS-GP.....	14

DRAWINGS

	Page
4502-001 IP231 BLOCK DIAGRAM.....	15
4502-002 ANALOG OUTPUT CONNECTIONS.....	16
4501-434 IP MECHANICAL ASSEMBLY.....	16
4501-462 CABLE 5025-550 (NON-SHIELDED).....	17
4501-463 CABLE 5025-551 (SHIELDED).....	17
4501-464 TERMINATION PANEL 5025-552.....	18
4501-465 TRANSITION MODULE TRANS-GP.....	18

IMPORTANT SAFETY CONSIDERATIONS

It is very important for the user to consider the possible adverse effects of power, wiring, component, sensor, or software failures in designing any type of control or monitoring system. This is especially important where economic property loss or human life is involved. It is important that the user employ satisfactory overall system design. It is agreed between the Buyer and Acromag, that this is the Buyer's responsibility.

1.0 GENERAL INFORMATION

The Industrial I/O Pack (IP) Series IP231 module is a 16-bit, high-density, single-size IP, analog output board with the capability to drive up to 16 analog voltage output channels. The IP231 utilizes state of the art Surface-Mounted Technology (SMT) to achieve its high channel density and is an ideal choice for many industrial control and scientific applications that require high-density, high-reliability, and high-performance at a low cost.

MODEL	# OUTPUTS	OPERATING TEMPERATURE RANGE
IP231-16	16	0 to 70°C
IP231-8	8	0 to 70°C
IP231-16E	16	-40 to 85°C
IP231-8E	8	-40 to 85°C

KEY IP231 FEATURES

- **High Channel Count** - Individual control of up to 16 analog voltage output channels is provided. Four units mounted on a carrier board provide up to 64 output channels in a single system slot.
- **16-Bit Accuracy** - Each channel contains its own 16-bit, Digital to Analog Converter (DAC) with an 13µs output settling time.
- **Bipolar Outputs** - Provides bipolar voltage range outputs: -10 to +10 Volts.
- **Reliable Software Calibration** - Calibration coefficients stored on-board provide the means for accurate software calibration of the module.
- **Individual Output Control** - Output channels can be individually selected and updated with a single channel data write command when using the "transparent" output mode.
- **Simultaneous Output Control** - All output channels can be simultaneously updated with a single software trigger command when using the "simultaneous" output mode (DAC's are double-buffered which allows new data to be written to each channel before the simultaneous trigger updates the outputs).
- **Easy Mode Selection** - Selection of transparent and simultaneous output modes is easily done via software commands.

- **Reset is Failsafe** - Outputs reset to 0 volts following a power up or reset.

INDUSTRIAL I/O PACK INTERFACE FEATURES

- **High density** - Single-size, industry standard, IP module footprint. Up to five units may be mounted on a carrier board.
- **Local ID** - Each IP module has its own 8-bit ID PROM which is accessed via data transfers in the "ID Read" space.
- **16-bit I/O** - Control register writes, DAC writes, and calibration coefficient reads are performed through 16-bit data transfer cycles in the IP module Input/Output space.
- **High Speed** - This IP model performs one "wait" state DAC write cycles.
- **Hold State Support** - This IP module supports "Hold" states, if generated by the carrier board.

SIGNAL INTERFACE PRODUCTS

(See Appendix for more information on compatible products)

This IP module will mate directly to any industry standard IP carrier board (including Acromag's AVME9630/60/70/75 VMEbus, APC8620/21 PCI bus, and ACPC8625/30/35 Compact PCI bus non-intelligent carrier boards). A wide range of other Acromag IP modules are also available to serve your signal conditioning and interface needs. Consult the documentation of your carrier board to ensure compatibility with the following interface products (since all connections to field signals are made through the carrier board which passes them to the individual IP modules).

Cables:

Model 5025-551-X (Shielded Cable) or Model 5025-550-X (Non-Shielded Cable): A Flat 50-pin cable with female connectors at both ends for connecting AVME9630/9660, or other compatible carrier boards, to Model 5025-552 termination panels. The unshielded cable is recommended for digital I/O, while the shielded cable is recommended for optimum performance with this module and for precision analog I/O applications.

Termination Panel:

Model 5025-552: DIN-rail mountable panel provides 50 screw terminals for universal field I/O termination. Connects to Acromag AVME9630/9660, or other compatible carrier boards, via flat 50-pin ribbon cable (Model 5025-550-X or 5025-551-X).

Transition Module:

Model TRANS-GP: This module repeats field I/O connections of IP modules A through D for rear exit from the card cage. It is available for use in card cages which provide rear exit for I/O connections via transition modules (transition modules can only be used in card cages specifically designed for them). It is a double-height (6U), single-slot module with front panel hardware adhering to the VMEbus mechanical dimensions, except for shorter printed circuit board depth. Connects to Acromag Termination Panel 5025-552 from the rear of the card cage, and to AVME9630/ 9660 boards within the card cage, via flat 50-pin ribbon cable (cable Model 5025-550-X or 5025-551-X).

IP MODULE Win32 DRIVER SOFTWARE

Acromag provides a software product (sold separately) to facilitate the development of Windows (98/Me/2000/XP®) applications accessing Industry Pack modules installed on Acromag PCI Carrier Cards and CompactPCI Carrier Cards. This software (Model IPSW-API-WIN) consists of low-level drivers and Windows 32 Dynamic Link Libraries (DLLS) that are compatible with a number of programming environments including Visual C++, Visual Basic, Borland C++ Builder and others. The DLL functions provide a high-level interface to the carriers and IP modules eliminating the need to perform low-level reads/writes of registers, and the writing of interrupt handlers.

IP MODULE VxWORKS SOFTWARE

Acromag provides a software product (sold separately) consisting of IP module VxWorks® libraries. This software (Model IPSW-API-VXW) is composed of VxWorks® (real time operating system) libraries for all Acromag IP modules and carriers including the AVME9670, AVME9660/9630, APC8620/21, ACPC8630/35, and ACPC8625. The software is implemented as a library of "C" functions. These functions link with existing user code to make possible simple control of all Acromag IP modules and carriers.

IP MODULE QNX SOFTWARE

Acromag provides a software product (sold separately) consisting of board QNX® software. This software (Model IPSW-API-QNX) is composed of QNX® (real time operating system) libraries for all Acromag IP modules and carriers including the AVME9670, AVME9660/9630, APC8620/21, ACPC8630/35, and ACPC8625. The software supports X86 PCI bus only and is implemented as library of "C" functions. These functions link with existing user code to make possible simple control of all Acromag IP modules and carriers.

2.0 PREPARATION FOR USE

UNPACKING AND INSPECTION

Upon receipt of this product, inspect the shipping carton for evidence of mishandling during transit. If the shipping carton is badly damaged or water stained, request that the carrier's agent be present when the carton is opened. If the carrier's agent is absent when the carton is opened and the contents of the carton are damaged, keep the carton and packing material for the agent's inspection.

For repairs to a product damaged in shipment, refer to the Acromag Service Policy to obtain return instructions. It is suggested that salvageable shipping cartons and packing material be saved for future use in the event the product must be shipped. This board is physically protected with packing material and electrically protected with an anti static bag during shipment. It is recommended that the board be visually inspected for evidence of mishandling prior to applying power.



The board utilizes static sensitive components and should only be handled at a static-safe workstation.

CARD CAGE CONSIDERATIONS

Refer to the specifications for loading and power requirements. Be sure that the system power supplies are able to accommodate the power requirements of the carrier board, plus the installed IP modules, within the voltage tolerances specified.

IMPORTANT: Adequate air circulation must be provided to prevent a temperature rise above the maximum operating temperature.

The dense packing of the IP modules to the carrier board restricts air flow within the card cage and is cause for concern. Adequate air circulation must be provided to prevent a temperature rise above the maximum operating temperature and to prolong the life of the electronics. If the installation is in an industrial environment and the board is exposed to environmental air, careful consideration should be given to air-filtering.

BOARD CONFIGURATION

The board may be configured differently, depending on the application.

Power should be removed from the board when installing IP modules, cables, termination panels, and field wiring. Refer to Mechanical Assembly Drawing 4501-434 and your IP module documentation for configuration and assembly instructions.

Default Hardware Configuration

A board is shipped from the factory configured as follows:

- Analog output range is -10 to +10 Volts and is not configurable.
- Programmable software register bits are undefined at reset, but the board defaults to 0 Volts on all analog outputs and the Simultaneous Channel Update Mode (see Section 3).

Programmable Register Configuration

Programmable registers are software configurable. That is, there are no hardware jumpers associated with them. Registers must be accessed to select the desired mode of operation and to update analog outputs (refer to Section 3 for details).

Analog Output Data Format

The bipolar output range (-10 to +10 Volts) is programmed with Bipolar Offset Binary (BOB) data to the Digital-to-Analog-Converter

(DAC). The following table indicates the relationship between the data format and the ideal analog output voltage from the module.

Table 2.2: Bipolar Offset Binary (BOB) Output Data Format

Analog Output Voltage (Volts)	BOB Data (Hex)
9.99969	FFFF
9.99938	FFFE
.	.
0.000305	8001
0.000000	8000
-0.000305	7FFF
.	.
-9.99969	0001
-10.00000	0000

CONNECTORS

IP Field I/O Connector (P2)

P2 provides the field I/O interface connector for mating IP modules to the carrier board. P2 is a 50-pin receptacle female header (Comm Con 8066-50G2 or equivalent) which mates to the male connector of the carrier board (AMP 173280-3 or equivalent). This provides excellent connection integrity.

Table 2.3: IP231 Field I/O Pin Connections (P2)

Pin Description	Number	Pin Description	Number
+CH00	1	-CH12 ¹	26
-CH00 ¹	2	+CH13	27
+CH01	3	-CH13 ¹	28
-CH01 ¹	4	+CH14	29
+CH02	5	-CH14 ¹	30
-CH02 ¹	6	+CH15	31
+CH03	7	-CH15 ¹	32
-CH03 ¹	8	RESERVED	33
+CH04	9	RESERVED	34
-CH04 ¹	10	RESERVED	35
+CH05	11	RESERVED	36
-CH05 ¹	12	RESERVED	37
+CH06	13	RESERVED	38
-CH06 ¹	14	RESERVED	39
+CH07	15	RESERVED	40
-CH07 ¹	16	RESERVED	41
+CH08	17	RESERVED	42
-CH08 ¹	18	RESERVED	43
+CH09	19	RESERVED	44
-CH09 ¹	20	RESERVED	45
+CH10	21	RESERVED	46
-CH10 ¹	22	NC ²	47 ²
+CH11	23	RESERVED	48
-CH11 ¹	24	NC ²	49 ²
+CH12	25	COMMON ¹	50

Note: 1. The minus leads of all channels are connected to analog common on the module.

2. The ±12 volt analog power supplies are provided via the P1 connector by default. External power supply pins 47 and 49 can only be used if the IP231 is built at the factory for external analog power.

Threaded metric M2 screws and spacers are supplied with the module to provide additional stability for harsh environments (see Mechanical Assembly Drawing 4501-434). The field and logic side connectors are keyed to avoid incorrect assembly. P2 Pin assignments are unique to each IP (see Table 2.3) and normally correspond to the pin numbers of the front panel, field I/O interface connector on the carrier board (you should verify this for your carrier board). In Table 2.3, channel designations are abbreviated to save space (i.e. channel 0 is abbreviated as "+CH00" & "-CH00" for the + & - connections, respectively). Further, note the output signals all have the same ground reference ("-CH00" and the minus leads of all other channels are connected to analog common on the module).

Analog Output Noise and Grounding Considerations

All output channels are referenced to analog common on the module (See Drawing 4502-002 for analog output connections), but each channel has a separate return (minus lead) to maintain accuracy and reduce noise. Still, the accuracy of the voltage output depends on the amount of current loading (impedance of the load) and the length (impedance) of the cabling. High impedance loads (e.g. loads > 100KΩ) provide the best accuracy. For low impedance loads, the IP231 can source up to 5mA, but the effects of source and cabling resistance should be considered.

Output common is electrically connected to the IP module ground. As such, the IP231 is non-isolated between the logic and field I/O grounds. Consequently, the field I/O connections are not isolated from the carrier board and backplane. Care should be taken in designing installations without isolation to avoid noise pickup and ground loops caused by multiple ground connections. This is particularly important for analog outputs when a high level of accuracy/resolution is needed (e.g. 16-bits). Refer to Drawing 4502-002 for example output and grounding connections. Contact your Acromag representative for information on our many isolated signal conditioning products that could be used to provide isolated voltage or current outputs when used in conjunction with the IP231 output module.

IP Logic Interface Connector (P1)

P1 of the IP module provides the logic interface to the mating connector on the carrier board. This connector is a 50-pin female receptacle header (Comm Con 8066-50G2 or equivalent) which mates to the male connector of the carrier board (AMP 173280-3 or equivalent). This provides excellent connection integrity. Threaded metric M2 screws and spacers are supplied with the IP module to provide additional stability for harsh environments (see Drawing 4501-434 for assembly details). Field and logic side connectors are keyed to avoid incorrect assembly. The pin assignments of P1 are standard for all IP modules according to the Industrial I/O Pack Specification (see Table 2.4). Note that the IP231 does not utilize all of the logic signals defined for the P1 connector. Logic lines NOT USED used by this model are indicated in **BOLD ITALICS**.

Table 2.4: Standard Logic Interface Connections (P1)

Pin Description	Number	Pin Description	Number
GND	1	GND	26
CLK	2	+5V	27
Reset*	3	R/W*	28
D00	4	IDSEL*	29
D01	5	<i>DMAReq0*</i>	30
D02	6	MEMSEL*	31
D03	7	<i>DMAReq1*</i>	32
D04	8	IntSel*	33
D05	9	<i>DMAck0*</i>	34
D06	10	IOSEL*	35
D07	11	RESERVED	36
D08	12	A1	37
D09	13	<i>DMAEnd*</i>	38
D10	14	A2	39
D11	15	ERROR*	40
D12	16	A3	41
D13	17	<i>INTReq0*</i>	42
D14	18	A4	43
D15	19	<i>INTReq1*</i>	44
BS0*	20	A5	45
BS1*	21	STROBE*	46
-12V	22	A6	47
+12V	23	ACK*	48
+5V	24	RESERVED	49
GND	25	GND	50

Asterisk (*) is used to indicate an active-low signal. **BOLD ITALIC** Logic Lines are NOT USED by this IP Model.

3.0 PROGRAMMING INFORMATION

This board is addressable in the Industrial Pack I/O space to control the level of analog outputs in the field and to read offset and gain calibration coefficients. The I/O space may be as large as 64, 16-bit words (128 bytes) using address lines A1..A6. The IP231 uses this address space for enabling control signals for DAC functions and addressing offset and gain calibration coefficients used by the software to adjust the accuracy of the output range. The calibration coefficients are accessed via reads from EEPROM in the I/O space. The I/O space address map for the IP231 is shown in Table 3.1 below. Note the base addresses for the IP module I/O space (see your carrier board instructions) must be added to the addresses shown to properly access the I/O space.

This manual is presented using the "Big Endian" byte ordering format. Big Endian is the convention used in the Motorola 68000 microprocessor family and is the VMEbus convention. In Big Endian, the lower-order byte is stored at odd-byte addresses. Thus, byte accesses are done on odd address locations. The Intel x86 family of microprocessors use the opposite convention, or "Little Endian" byte ordering. Little Endian uses even-byte addresses to store the low-order byte. As such, use of this module on a PC carrier board will require the use of the even address locations to access the data, while a VMEbus carrier will require the use of odd address locations.

ADDRESS MAPS

Table 3.1: IP231 I/O Space Address Memory Map

Base Address + (Hex)	Even Byte		Odd Byte	
	D15	D08	D07	D00
00		(R/W) - DAC Channel 0		
02		(R/W) - DAC Channel 1		
04		(R/W) - DAC Channel 2		
06		(R/W) - DAC Channel 3		
08		(R/W) - DAC Channel 4		
0A		(R/W) - DAC Channel 5		
0C		(R/W) - DAC Channel 6		
0E		(R/W) - DAC Channel 7		
10		(R/W) - DAC Channel 8 ²		
12		(R/W) - DAC Channel 9 ²		
14		(R/W) - DAC Channel 10 ²		
16		(R/W) - DAC Channel 11 ²		
18		(R/W) - DAC Channel 12 ²		
1A		(R/W) - DAC Channel 13 ²		
1C		(R/W) - DAC Channel 14 ²		
1E		(R/W) - DAC Channel 15 ²		
20		(W) - Transparent Mode		
22		(W) - Simultaneous Mode		
24		(W) - Simultaneous Output Trigger		
26		DAC Write Status Register		
28		Control Register		
2A	EEPROM Status		EEPROM Write Control	
2C	NOT USED ¹			
↓				
3E				
40		(R)-CH0 Offset Error		
42		(R)-CH0 Gain Error		
44		(R)-CH1 Offset Error		
46		(R)-CH1 Gain Error		
48		(R)-CH2 Offset Error		
4A		(R)-CH2 Gain Error		
4C		(R)-CH3 Offset Error		
4E		(R)-CH3 Gain Error		
50		(R)-CH4 Offset Error		
52		(R)-CH4 Gain Error		
54		(R)-CH5 Offset Error		
56		(R)-CH5 Gain Error		
58		(R)-CH6 Offset Error		
5A		(R)-CH6 Gain Error		
5C		(R)-CH7 Offset Error		
5E		(R)-CH7 Gain Error		
60		(R)-CH8 Offset Error ²		
62		(R)-CH8 Gain Error ²		
64		(R)-CH9 Offset Error ²		
66		(R)-CH9 Gain Error ²		
68		(R)-CH10 Offset Error ²		
6A		(R)-CH10 Gain Error ²		
6C		(R)-CH11 Offset Error ²		
6E		(R)-CH11 Gain Error ²		
70		(R)-CH12 Offset Error ²		
72		(R)-CH12 Gain Error ²		
74		(R)-CH13 Offset Error ²		
76		(R)-CH13 Gain Error ²		
78		(R)-CH14 Offset Error ²		
7A		(R)-CH14 Gain Error ²		
7C		(R)-CH15 Offset Error ²		
7E		(R)-CH15 Gain Error ²		

Notes (Table 3.1):

1. The IP will respond to addresses that are "Not Used" with an active IP module acknowledge ACK*. Data read at "Not Used" addresses will be driven low.
2. Channels 8-15 are present in the IP231-16 Model, only.

The following sections give details on the function of each location in the I/O space noted above.

IP Identification - (Read Only, 32 odd-byte addresses)

Each IP module contains an identification (ID) that resides in the ID space per the IP module specification. This area of memory contains 32 bytes of information at most. Both fixed and variable information may be present within the ID. Fixed information includes the "IPAC" identifier, model number, and manufacturer's identification codes. Variable information includes unique information required for the module. The IP231 ID bytes are addressed using only the odd addresses in a 64-byte block. The IP231 ID contents are shown in Table 3.2. Note that the base-address for the IP module ID space (see your carrier board instructions) must be added to the addresses shown to properly access the ID. Execution of an ID Read requires 0 wait states.

Table 3.2: IP231 ID Space Identification (ID)

Hex Offset From ID PROM Base Address	ASCII Character Equivalent	Numeric Value (Hex)	Field Description
01	I	49	All IP's have 'IPAC'
03	P	50	
05	A	41	
07	C	43	
09		A3	Acromag ID Code
0B		34 IP231-16 33 IP231-8	IP Model Code
0D		00	Not Used (Revision)
0F		00	Reserved
11		00	Not Used (Driver ID Low Byte)
13		00	Not Used (Driver ID High Byte)
15		0C	Total Number of ID PROM Bytes
17		0B IP231-16 4F IP231-8	CRC
19 to 3F		00	Not Used

DAC Channel Registers- (Read/Write, Base + 00H to 1EH)

The IP231 contains sixteen (16) DAC Channel Registers in the I/O space. Table 3.1 lists each of the DAC Channel registers with their corresponding hex address in I/O space memory.

The DAC Channel registers are read/write registers and are used to hold the 16-bit digital value that are output to the Digital-to-Analog-Converter's (DAC's). The 16-bits of DAC data are written to the DAC register with the least significant bit at data bit-0. The data format is Bipolar Offset Binary (BOB, see Section 2 for details).

The contents of the DAC Channel registers are transferred to their corresponding converter input buffer serially. This serial data transfer take 2µs. Thus, a new write of the same DAC register can be performed no sooner then 2µs after the previous write. A DAC Write Status register, at base address plus 26H, is available as a write operation busy status indicator. The channels Status bit will be set low upon initiation of a write operation and will remain low until the requested write operation has completed. New write accesses to the same DAC Channel register, should not be initiated unless its write busy status bit is set high. Read of the DAC Channel register should also wait 2µs after a write, to avoid read of the register as it is being serially shift out.

RESET CONDITION: All output channels are set to "0 Volts".

Note: The reset function resets only the DAC output latch of the input double buffer. Therefore, after a reset, good data must be written to all the input latches before a DAC output update by enabling the Transparent Mode, or enabling the Simultaneous Output Trigger. Otherwise, old data or unknown data present in the input latches will be transferred to the DAC output latch producing an undesired analog output.

Execution of a DAC channel write or read command requires one wait state.

Transparent Mode - (Write, Base + 20H)

The Transparent Mode is a write-only register in the I/O space that is used to select and enable the transparent type of data transfer (it will not respond to reads). Once the Transparent Mode is selected, 16-bit digital data written to the address specific channel's input latch will automatically be converted and transferred to the board's field connector. The data is transferred from the input latch, through the DAC latch (transparent in this mode), to the analog output field connector until a reset, Simultaneous Mode, or Simultaneous Output Trigger is enabled. Execution of a Transparent Mode write command requires 1 wait state. The data written to this location (D16) is immaterial, since the write is sufficient to complete the action.

D15...D00
X..X

"X" means "DON'T CARE" - the bit value does not matter.

RESET CONDITION: Defaults to Simultaneous Mode. All register bits are undefined. All analog output channels are set to "0 Volts".

Note: The reset function resets only the DAC output latch of the input double buffer. Therefore, after a reset, good data must be written to all the input latches before enabling the

Transparent Mode or enabling the Simultaneous Output Trigger for a DAC output update. Otherwise, old or unknown data present in the input latches will be transferred to the DAC output latch producing an undesired analog output.

In the Transparent Mode, the Simultaneous Mode can be activated by a write to the Simultaneous Output Trigger register.

Simultaneous Mode - (Write, Base + 22H)

The Simultaneous Mode is a write-only register (will not respond to reads) in the I/O space that is used to select the simultaneous type of data transfer. Once the Simultaneous Mode is selected, 16-bit digital data written to the address specific channel's input latch will continue to be held until the Simultaneous Output Trigger register is written, before digital data is transferred to the output latch (and the updated analog output appears at the board's field connector). The data, of all the channels, is simultaneously transferred, **once per simultaneous trigger**, from the DAC input latch to the output latch (and analog output updated) **only** when the Simultaneous Output Trigger register is enabled. Execution of a Simultaneous Mode Write command requires 1 wait state. The data written to this location (D16) is immaterial, since the write is sufficient to complete the action.

D15...D00
X..X

"X" means "Don't Care" - the bit value does not matter.

RESET CONDITION: Defaults to Simultaneous Mode. All register bits are undefined. All analog output channels are set to "0 Volts".

Note: The reset function resets only the DAC output latch of the input double buffer. Therefore, after a reset, good data must be written to all the input latches before enabling the Transparent Mode or enabling the Simultaneous Output Trigger for a DAC output update. Otherwise, old data or unknown data present in the input latches will be transferred to the DAC output latch producing an undesired analog output.

The Simultaneous Mode can also be activated while in Transparent Mode if a write occurs to the Simultaneous Output Trigger register.

Simultaneous Output Trigger - (Write, Base + 24H)

The Simultaneous Output Trigger is a write-only register (will not respond to reads) in the I/O space that produces the pulse needed to trigger the simultaneous type of data transfer. The Simultaneous Output Trigger register works in conjunction with the Simultaneous Mode register to simultaneously transfer all the channels' digital data from the DAC input latch to the output latch (and update the analog output) at a specific time. The Simultaneous Mode register must be written to first. Then, writing to the Simultaneous Output Trigger register creates the trigger for digital data to be converted and transferred to the board's field connector. The 16-bit digital data written to the address specific channel's input latch will continue to be held until the Simultaneous Output Trigger register is written. This will trigger the transfer of digital data from the DAC input latch to the output latch and the digital to analog conversion producing the updated analog output. Execution of a Simultaneous Output Trigger Write command requires 1 wait state. The data written to this

location (D16) is immaterial, since the write is sufficient to complete the action.

D15...D00
X...X

"X" means "Don't Care" - the bit value does not matter.

RESET CONDITION: Defaults to Simultaneous Mode. All register bits are undefined. All analog output channels are set to "0 Volts".

Note: The reset function resets only the DAC output latch of the input double buffer. Therefore, after a reset, good data must be written to all the input latches before enabling the Transparent Mode or enabling the Simultaneous Output Trigger for a DAC output update. Otherwise, old data or unknown data present in the input latches will be transferred to the DAC output latch producing an undesired analog output.

The Simultaneous Mode can also be activated while in Transparent Mode if a write occurs to the Simultaneous Output Trigger register.

DAC Write Status Register - (Read, Base + 26H)

This DAC Write Status register can be read to monitor the busy status after a write to a DAC channel. New write of a DAC Channel register can be performed no sooner than 2µs after the previous DAC write command is executed.

The status of 16 DAC channels numbered 0 through 15 may be monitored via this register. Data bits 0 to 15 reflect the status of DAC channels 0 to 15. The channels corresponding status bit will be set low upon initiation of a write operation and will remain low until the requested write operation has completed. New write accesses to the DAC Channel register should not be initiated unless its write busy status bit is set high.

Control Register - (Read/Write, Base + 28H)

This register is used to issue a software reset to the IP231. Setting bit-7 of this register to a logic high "1" will reset all analog output channels to "0 Volts".

Note: The reset function resets only the DAC output latch of the input double buffer. Therefore, after a reset, good data must be written to all the input latches before enabling the Transparent Mode or enabling the Simultaneous Output Trigger for a DAC output update. Otherwise, old data or unknown data present in the input latches will be transferred to the DAC output latch producing an undesired analog output.

This register is cleared (set to "0") following a reset. Reading or writing this register is possible via 16-bit or 8-bit data transfers.

EEPROM Write Control Register - (Read/Write, Base + 2AH)

Writes to the coefficient memory device require a special enable code. Writes to memory are normally only performed at the factory. The module should be returned to Acromag if the coefficients must be re-measured and stored to memory.

Write operations to coefficient memory are enable by setting bits 0 and 1 to logic high. Write operations to the coefficient memory at base address plus 40H to 7FH will take approximately 1m seconds.

Bit-15 of the EEPROM Status register serves as write operation busy status indicator. Status bit-15 will be set low upon initiation of a write operation and will remain low until the requested write operation has completed. New write accesses to the coefficient memory, should not be initiated unless the write busy status bit-15 is set high.

EEPROM Status Register - (Read, Base + 2BH)

This register is used to monitor the busy status after a write to the coefficient memory device. The DAC coefficients are measured and written at the factory. Reading bit-15 of this register can be used to detect the end of a coefficient memory write cycle. Bit-15 is actively pulled low "0" during the write cycle and is released to logic high "1" at completion of the write.

Channel Offset/Gain Error Coeff. - (Read, Base + 41 to 7FH)

Calibration data is provided in the form of calibration coefficients, so the user can adjust and improve the accuracy of the analog output voltage over the uncalibrated state. Each channel's unique offset and gain calibration coefficients are stored in a EEPROM. These coefficients can be retrieved (read-only) by accessing the last 64 bytes (40H to 7FH) of the I/O space (D08 accesses only). The offset and gain calibration coefficients read from the EEPROM are stored with 1/4-LSB resolution. Thus, it is necessary to divide each coefficient by four to correctly use them when calibrating the bipolar outputs. Each is stored as a two's-complement (i.e. signed) sixteen-bit number. This number has a range of -32,768 to +32,767. Execution of a Channel Offset or Gain Error Read command requires 1 wait state.

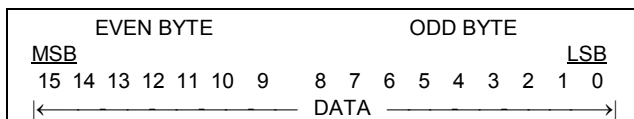

PROGRAMMING CONSIDERATIONS FOR ANALOG OUTPUTS

The IP231 provides two methods of analog output programming for maximum flexibility with different applications. The following paragraphs describe the features of each and how to best use them.

Using the Transparent Mode

Use of the Transparent Mode provides the quickest method of updating the desired analog output. This method is geared for those applications that require maximum speed without the need for updating all channels simultaneously. In Transparent Mode, each analog output channel is updated as soon as it is written to. Multiple channels may be written to separately, resulting in the analog outputs being updated one channel at a time. Functionally, the input latch is written to, and the DAC latch is automatically updated, providing more speed by eliminating a separate write instruction.

Transparent Mode Programming Example

1. Write to the Transparent Mode register to setup the transparent type of data transfer.
2. Read the EEPROM to acquire the channel's unique offset and gain calibration coefficient data. This data is necessary to

adjust, by software, the accuracy of the involved channel's analog output. See USE OF CALIBRATION DATA.

3. Write the 16-bit digital data to the desired DAC Channel Register.
4. (OPTIONAL) Observe or monitor that the specific DAC channel reflects the results of the digital data converted to an analog output voltage at the field connector.
5. Repeat steps 1-4 until all the desired channels reflect the updated analog output voltage at the field connector.

Using the Simultaneous Mode

Use of the Simultaneous Mode provides a method of distributing data simultaneously and synchronously to produce desired analog outputs. This method is useful for applications that require updating all the channels simultaneously and synchronously. Each channel is written to with the required 16-bit data. When all the required channels contain the desired digital data, then a write to the Simultaneous Output Trigger register will produce a pulse to simultaneously trigger each channel's digital to analog converter. Thus, all the analog outputs are updated simultaneously. Functionally, each input latch is written to separately. When all input latches contain the desired digital data, then all channels are pulsed simultaneously and synchronously to convert to the updated analog output voltage.

Simultaneous Mode Programming Example

1. Write to the Simultaneous Mode register to setup the simultaneous type of data transfer.
2. Read the EEPROM to acquire the channel's unique offset and gain calibration coefficient data. This data is necessary to adjust, by software, the accuracy of the involved channel's analog output. See USE OF CALIBRATION DATA.
3. Write the 16-bit digital data to the desired DAC Channel Register.
4. Repeat steps 2-3 to write new digital data to the DAC Channel Registers for all other channels requiring update.
5. Write to the Simultaneous Output Trigger register to produce a pulse to simultaneously trigger digital to analog conversions for all channels, resulting in updated analog output voltages at the field connector.
6. (OPTIONAL) Observe or monitor that DAC channels reflect the results of the digital data converted to an analog output voltage at the field connector.
7. Repeat steps 2-6 for continued simultaneous and synchronous triggered updates of all desired channels.

USE OF CALIBRATION DATA

Calibration data is provided in the form of calibration coefficients, so the user can adjust and improve the accuracy of the analog output voltage over the uncalibrated state. Each channel's unique offset and gain calibration coefficients are stored in the EEPROM. The use of software calibration allows the elimination of hardware calibration potentiometers traditionally used in producing precision analog outputs. A comparison of the uncalibrated and software calibrated performance is shown to illustrate the importance of the software calibration.

Software calibration uses some fairly complex equations. Acromag provides software products (sold separately) to make communication with the board and calibration easy. It relieves you from having to turn the equations of the following sections into debugged software calibration code.

Uncalibrated Performance

The uncalibrated performance is affected by two primary error sources. These are the channel's offset and gain errors. The use of channel specific calibration coefficients to accurately adjust offset and gain is important because the worst case uncalibrated error can be significant (although the typical uncalibrated errors observed may be much less). The maximum uncalibrated error is summarized as follows:

AD5570 @ 25°C:

- Linearity Error is +/- 0.003% maximum (i.e. +/-2 LSB).
- Bipolar Offset Error is +/- 0.038% FSR (i.e. 20V SPAN) maximum.
- Gain Error is +/- 0.038% FSR maximum.

Table 3.3 summarizes the maximum uncalibrated error combining the linearity, offset and gain errors:

Table 3.3: Maximum Overall Uncalibrated Error

Max. Linearity Error (%)	Max. Offset Error (%)	Max. Gain Error (%)	Max. Total Error* (%)
+/-0.003	+/-0.038	+/-0.038	+/-51.8 LSB (+/-0.079)

* This represents the worst case error with all errors summed. Typically, each error component is much less than its maximum and all error components do not reinforce each other. Thus, typical errors are much less than that shown in the table above.

Calibrated Performance

Accurate calibration of the IP231 can be accomplished through software control by using calibration coefficients to adjust the analog output voltage. Unique calibration coefficients are stored in the EEPROM as 1/4 LSB's for each specific channel. Once retrieved, the channel's unique offset and gain coefficients can be used to correct the data value sent to the DAC channel to accurately generate the desired output voltage.

Table 3.4 summarizes the maximum calibrated error combining the linearity and adjusted offset and gain errors:

Table 3.4: Maximum Overall Calibrated Error

Max. Linearity Error LSB	Max. Offset Error LSB	Max. Gain Error LSB	Max. Total Error LSB (%)
+/-2.0	+/-0.25	+/-0.25	+/-2.5LSB (+/-0.004)

Thus, correcting the value programmed to the DAC Channel Register using the stored calibration coefficients provides the means to obtain excellent accuracy.

Data is corrected using a couple of formulas. Equation (1) expresses the ideal relationship between the value (ideal_count) written to the 16-bit DAC to achieve a specified voltage within the -10 to +10 Volt output range assuming Bipolar Offset Binary (BOB) data format (see Section 2 for details).

$$\text{Ideal_Count} = [(\text{Count_Span} / \text{Ideal_Volt_Span}) * \text{Desired_Voltage}] + \text{Ideal_Zero_Count} \tag{1}$$

where,

Count_Span = 65,536 (a 16-bit converter has 2^{16} possible levels)
Ideal_Volt_Span = 20 Volts (for the bipolar -10 to +10 Volt range)
Ideal_Zero_Count = 32,768 (count for an ideal output of 0 Volts)

Equation (1) can be simplified using the above constants, since the range and DAC are fixed on the IP231. Equation (2) results:

$$\text{Ideal_Count} = [(65,536 / 20) * \text{Desired_Voltage}] + 32,768 \quad (2)$$

Using equation (2), one can determine the ideal count for any desired voltage within the range. For example, if it is desired to output a voltage of +5 Volts, equation (2) returns the result 49,152 for **Ideal_Count**. If this value is used to program the DAC output (following conversion to Hex), the output value will approach +5 Volts to within the uncalibrated error specified in Table 3.3. This will be acceptable for some applications.

For applications needing better accuracy, the software calibration coefficients should be used to correct the **Ideal_Count** into the **Corrected_Count** required to accurately produce the output voltage. This is illustrated in equation (3):

$$\text{Corrected_Count} = [(\text{Ideal_Gain} + \text{Gain_Correction}) * (\text{Ideal_Count} - \text{Ideal_Zero_Count})] + (\text{Ideal_Zero_Count} + \text{Offset_Correction}) \quad (3)$$

where,

Ideal_Gain = 1
Gain_Correction = PROM_Gain_Error / 262,144
Offset_Correction = PROM_Offset_Error / 4

Ideal_Count is determined from equation (2) and **Ideal_Zero_Count** remains 32,768. **PROM_Gain_Error** and **PROM_Offset_Error** are obtained from the EEPROM on the IP231 on a per channel basis. Equation (3) can be written as (4) by making the listed substitutions:

$$\text{Corrected_Count} = [(1 + (\text{PROM_Gain_Error} / 262,144)) * (\text{Ideal_Count} - 32,768)] + (32,768 + (\text{PROM_Offset_Error} / 4)) \quad (4)$$

Using equation (4), you can determine the corrected count from the ideal count. For the previous example, equation (2) returned a result 49,152 for the **Ideal_Count** to produce an output of +5 Volts. Assuming that a gain error of +33 and an offset error of -25 are read from the PROM on the IP231 for the desired channel, substitution into equation (4) yields:

$$\text{Corrected_Count} = [(1 + (33 / 262,144)) * (49,152 - 32,768)] + (32,768 + (-25 / 4)) = 49,147.8125$$

If this value (rounded to 49,148) is used to program the DAC output (following conversion to Hex), the output value will approach +5 Volts to within the calibrated error specified in Table 3.4 (+/-1 LSB). Note that the quantization error (up to 0.5 LSB) introduced by rounding to 49,148 is not included in the overall accuracy specification.

Calibration Programming Example

The available bipolar range, centered around 0 Volts is -10 to +10 Volts. Assume it is necessary to program channel 0 with an output of -2.5 Volts.

1. Write to the Transparent Mode register @BASE + 20H with data of FFFFH to select the Transparent Mode. In this mode, data written to the Channel Register will be automatically transferred

from the input latch to the output latch and converted to the desired output.

2. Read the EEPROM to retrieve the channel's unique offset calibration error data. For channel 0, read byte @BASE + 41H. Also read the most significant byte at @BASE + 40H. This 16-bit two's complement number is assumed 20H. This corresponds to a **PROM_Offset_Error** of +32 decimal.
3. Read the EEPROM to retrieve the channel's unique gain calibration error data. For channel 0, read byte @BASE + 43H. Also, read the most significant byte @BASE + 42H. An 16-bit two's complement number is assumed FFF1H. This corresponds to a **PROM_Gain_Error** of -15 decimal.
4. Calculate the **Ideal_Count** required to provide an uncorrected output of the desired value (-2.5 Volts) by using equation (2).
Ideal_Count = [(65536 / 20) * -2.5] + 32,768 = 24,576
5. Calculate the **Corrected_Count** required to provide an accurate output of the desired value (-2.5 Volts) by using equation (4).
Corrected_Count = [(1 + (-15 / 262,144)) * (24,576 - 32,768)] + (32,768 + (32 / 4)) = 24,584.47
6. Write to the DAC Channel 0 Register @BASE + 00H with the desired data (6009H - data is determined by rounding 24,584.47 decimal to 24,585, then converting to Hex 6009).
7. (OPTIONAL) Observe or monitor that the specific DAC channel (0) reflects the results of the digital data converted to an analog output voltage at the field connector.
8. Repeat steps 2-7 to adjust the unique calibration characteristic and update each channel used, or repeat steps 4-7 to update the value of a single channel.

Error checking should be performed on the calculated count values to insure that calculated values below 0 or above 65,535 decimal are restricted to those end points. Note that the software calibration cannot generate outputs near the endpoints of the range which are clipped off due to the uncalibrated hardware (i.e. the DAC).

4.0 THEORY OF OPERATION

This section describes the basic functionality of the IP231 circuitry. Review the block diagram shown in Drawing 4502-001 as you study the following paragraphs.

ANALOG OUTPUTS

The field I/O interface to the carrier board is provided through connector P2 (refer to Table 2.3). Field analog outputs are NON-ISOLATED. This means that the field return, output channel minus, and logic common have a direct electrical connection to each other. As such, care must be taken to avoid ground loops and excessive output loading (see Section 2 for connection recommendations). Ignoring this effect may cause operation errors, and with extreme abuse, possible circuit damage. Refer to Drawing 4502-002 for example analog output and grounding connections.

The fully populated board contains sixteen 16-bit DAC's (IP231-16), one per channel. This allows each channel to be independently programmed for maximum speed and accuracy and avoids the problems associated with designs using sample and hold amplifiers multiplexed to a single DAC. Each DAC may source up to 5mA of output current without requiring separate buffer amplifiers. DAC calibration is done via software to avoid the mechanical drawbacks of hardware potentiometers for each DAC channel. This also conserves board space and helps to achieve high channel density. Calibration parameters are stored in EEPROM on a per channel basis.

DAC inputs are double-buffered. This allows channels to be programmed by either of two modes (software register selectable). The Transparent Mode allows channels to be updated quickly on an individual basis, since data written to the input latch is immediately transferred to the output latch and converted to an updated analog output voltage. Selection of the Simultaneous Mode allows many or all channels to be updated at once. In this mode, the data for channels is written to their associated input latch, but does not get transferred to the output latch until a Simultaneous Trigger command is sent. All channels update synchronously and simultaneously upon receipt of the trigger command.

LOGIC/POWER INTERFACE

The logic interface to the carrier board is made through connector P1 (refer to Table 2.4). Not all of the IP logic P1 pin functions are used.

The logic P1 interface provides ± 12 volt and +5V supplies to the module. If required, there is an option to provided ± 12 volt external supplies. The ± 12 volt analog power supplies are provided via the P1 connector by default. External power supply pins 47 and 49 can only be used if the IP231 is built at the factory for external analog power.

A programmable logic device installed on the IP Module provides the control signals required to operate the board. It decodes the selected addresses in the I/O and ID spaces, and produces the chip selects, control signals, and timing required by the DAC's, software registers, and ID information, as well as, the acknowledgement signal required by the carrier board per the IP specification. It also controls the mode selection and triggering to start DAC conversions for the Transparent and Simultaneous Modes.

The EEPROM installed on the IP module contains channel specific calibration coefficients to correct both offset and gain errors. The coefficients must be used to trim the outputs to within their accuracy specification. The EEPROM, software registers, and DAC's are all accessed through the 16-bit data bus interface to the carrier board.

5.0 SERVICE AND REPAIR

SERVICE AND REPAIR ASSISTANCE

Surface-Mounted Technology (SMT) boards are generally difficult to repair. It is highly recommended that a non-functioning board be returned to Acromag for repair. The board can be damaged unless special SMT repair and service tools are used. Further, Acromag has automated test equipment that thoroughly checks the performance of each board. When a board is first produced and when any repair is made, it is tested, placed in a burn-in room at elevated temperature, and retested before shipment.

Please refer to Acromag's Service Policy Bulletin or contact Acromag for complete details on how to obtain parts and repair.

PRELIMINARY SERVICE PROCEDURE

Before beginning repair, be sure that all of the procedures in Section 2, Preparation For Use, have been followed. Also, refer to the documentation of your carrier board to verify that it is correctly configured. Replacement of the module with one that is known to work correctly is a good technique to isolate a faulty module.

CAUTION: POWER MUST BE TURNED OFF BEFORE REMOVING OR INSERTING BOARDS

Acromag's Applications Engineers can provide further technical assistance if required. When needed, complete repair services are also available from Acromag.

6.0 SPECIFICATIONS

PHYSICAL

Physical Configuration..... Single Industrial Pack Module.
 Length..... 3.880 in. (98.5 mm).
 Width..... 1.780 in. (45.2 mm).
 Board Thickness..... 0.062 in. (1.59 mm).
 Max Component Height..... 0.290 in. (7.37 mm).

Connectors:

P1 (IP Logic Interface)..... 50-pin female receptacle header (Comm Con 8066-50G2 or equivalent).
 P2 (Field I/O)..... 50-pin female receptacle header (Comm Con 8066-50G2 or equivalent).

Power:

+5 Volts (±5%)..... 33mA, Typical
 45mA Maximum¹.
 +12 Volts (±5%) from P1..... 150mA, Typical
 200mA, Maximum¹
 -12 Volts (±5%) from P1..... 133mA, Typical
 180mA, Maximum¹

Notes

1. The maximum current draw assumes that the rated current of 5mA per channel is drawn. Current draw will be reduced proportionately for high impedance output loads.

Maximum Vcc Rise Time..... 100m seconds

ENVIRONMENTAL

Operating Temperature..... 0 to +70°C (Standard Version)
 -40°C to +85°C (E Versions)
 Relative Humidity..... 5-95% Non-Condensing.
 Storage Temperature..... -55°C to +125°C.
 Non-Isolated..... Logic and field commons have a direct electrical connection.
 Radiated Field Immunity (RFI).... Complies with EN61000-4-3 (3 V/m, 80 to 1000MHz AM & 900MHz. Keyed) and European Norm EN50082-1 with no register upsets and analog output error is < ± 0.5% of a 20V
 Conducted R F Immunity (CRFI) Complies with EN61000-4-6 (3 V/rms, 150KHz to 80MHz) and European Norm EN50082-1 with no register upsets and analog output error is < ± 0.5% of a 20V.
 Electromagnetic Interference Immunity (EMI)..... No register upsets occur under the influence of EMI from switching solenoids, commutator motors, and drill motors.
 Surge Immunity..... Not required for signal I/O per European Norm EN50082-1.
 Electric Fast Transient (EFT) Immunity Complies with EN61000-4-4 Level 2 (0.5KV at field input and output terminals) and European Norm EN50082-1.
 Electrostatic Discharge (ESD) Immunity Complies with EN61000-4-2 Level 3 (8KV enclosure port air discharge) Level 2 (4KV enclosure

port contact discharge) Level 1 (2KV I/O terminals contact discharge) and European Norm EN50082-1.
 Radiated Emissions..... Meets or exceeds European Norm EN50081-1 for class B equipment. Shielded cable with I/O connections in shielded enclosure are required to meet compliance.

ANALOG OUTPUTS

Output Channels (Field Access). IP231-16: 16 Single-Ended.
 IP231-8: 8 Single-Ended.
 Output Type..... Voltage (Non-isolated).
 Output Range..... Bipolar -10V to +10V (See Notes 2 & 3).
 Output Current..... -5mA to +5mA (Maximum); this corresponds to a minimum load resistance of 2KΩ with a 10V output (See Notes 2 & 3).
 Data Format (left-justified)..... Bipolar Offset Binary (BOB).
 DAC Programming..... Immediate (transparently programmed to DAC output); Simultaneous (input latches of multiple DAC's are loaded with new data before simultaneously updating DAC outputs).
 Resolution..... 16-bits.
 Monotonicity over Temperature... 16-bits.
 Linearity Error..... ±2 LSB (Maximum).
 Differential Linearity Error..... ±1 LSB (Maximum).
 System Accuracy..... ±0.00305% of 20V SPAN
 Maximum corrected error (i.e. calibrated) at 25°C (See Note 4) with the output unloaded.
 Settling Time..... 13µS to within 0.012% for a 20V step change (load of 5KΩ in parallel with 470 pf).
 Output at Reset..... Bipolar Zero Volts (See Note 5).
 Output Noise..... 2.0mV rms in a 20MHz bandwidth, Typical.
 Output Impedence..... 0.5Ω Maximum at 25°C (a load of 10KΩ will introduce 0.005% output error).
 Short Circuit Current..... 25mA
 Output Load Stability..... Maximum recommended capacitive load is 500pf. Capacitive loads above 500pf can be tolerated, but with additional overshoot.
 Gain Drift..... ±15ppm of 20V SPAN per °C Maximum.
 Bipolar Zero Drift..... ±10ppm of 20V SPAN per °C Maximum.

Notes (Analog Outputs):

2. Maximum output current (±5mA) can be achieved at the range endpoints using the internal ±12 volt power supplies sourced through P1. The internal supplies must not drop below ±12 volts to achieve maximum output current of ±5mA. A maximum output current of ±2mA is recommended for supplies at ±11.4 volts.
3. The actual outputs may fall short of the range endpoints due to hardware offset and gain errors. The software calibration

corrects for these across the output range, but cannot extend the output beyond that achievable with the hardware.

4. Offset and gain calibration coefficients stored in the EEPROM must be used to perform software calibration in order to achieve the specified accuracy. Specified accuracy does not include quantization error. Follow the output connection recommendations of Section 2, because non-ideal grounds can degrade overall system accuracy.
5. The reset function resets only the DAC (i.e. output) latch of the input double buffer. Therefore, after a reset, good data must be written to all the input latches before a simultaneous DAC output update. Otherwise, old data or unknown data present in the input latches will be transferred to the DAC output latch, producing an undesired analog output.

INDUSTRIAL I/O PACK COMPLIANCE

Specification..... This device meets or exceeds all written Industrial I/O Pack specifications per ANSI/VITA 4 1995 for 8MHz operation for Type I Modules.

Electrical/Mechanical

Interface..... Single-Size IP Module.
 I/O Space (IOSel*)..... 16-bit word write/read of 16-bit channel data; 16-bit write/read to control registers; 8-bit read of 16-bit offset and gain calibration coefficients.
 ID Space (IDSel*)..... 16 and 8-bit; Supports Type 1, 32 bytes per IP (consecutive odd byte addresses).

Access Times (8MHz Clock):

ID EEPROM Read..... 0 wait states (250ns cycle).
 DAC Channel Data Write⁶..... 2 wait state (500ns cycle).
 DAC Offset/Gain Coeff. Read..... 1 wait state (375ns cycle).
 Control Register Access..... 1 wait state (375ns cycle).

Notes

6. New read or write of the same DAC Channel register can be performed no sooner than 2µs after a DAC write command is executed. A DAC channel write after issue of a simultaneous trigger command will see additional wait states until the simultaneous trigger is executed at the DACs.

APPENDIX**CABLE: MODEL 5025-550-x (Non-Shielded)
MODEL 5025-551-x (Shielded)**

Type: Flat Ribbon Cable, 50-wires (female connectors at both ends). The '-x' suffix designates the length in feet (12 feet maximum). Choose shielded or unshielded cable according to model number. The unshielded cable is recommended for digital I/O, while the shielded cable is recommended for optimum performance with precision analog I/O applications.

Application: Used to connect Model 5025-552 termination panel to the AVME9630/9660 non-intelligent carrier board A-D connectors (Both have 50-pin connectors).

Length: Last field of part number designates length in feet (user-specified, 12 feet maximum). It is recommended that this length be kept to a minimum to reduce noise and power loss.

Cable: 50-wire flat ribbon cable, 28 gage. Non-Shielded cable model uses Acromag Part 2002-211 (3M Type C3365/50 or equivalent). Shielded cable model uses Acromag Part 2002-261 (3M Type 3476/50 or equivalent).

Headers (Both Ends): 50-pin female header with strain relief.

Header - Acromag Part 1004-512 (3M Type 3425-6600 or equivalent). *Strain Relief* - Acromag Part 1004-534 (3M Type 3448-3050 or equivalent).

Keying: Headers at both ends have polarizing key to prevent improper installation.

Schematic and Physical Attributes: For Non-Shielded cable model, see Drawing 4501-462. For Shielded cable model, see Drawing 4501-463.

Shipping Weight: 1.0 pound (0.5Kg), packed.

TERMINATION PANEL: MODEL 5025-552

Type: Termination Panel For AVME9630/9660 Boards

Application: To connect field I/O signals to the Industrial I/O Pack (IP). *Termination Panel*: Acromag Part 4001-040 (Phoenix Contact Type FLKM 50). The 5025-552 termination panel facilitates the connection of up to 50 field I/O signals and connects to the AVME9630/9660 3U/6U non-intelligent carrier boards (A-D connectors only) via a flat ribbon cable (Model 5025-550-x or 5025-551-x). The A-D connectors on the carrier board connect the field I/O signals to the P2 connector on each of the Industrial I/O Pack modules. Field signals are accessed via screw terminal strips. The terminal strip markings on the termination panel (1-50) correspond to P2 (pins 1-50) on the Industrial I/O Pack (IP). Each Industrial I/O Pack (IP) has its own unique P2 pin assignments. Refer to the IP module manual for correct wiring connections to the termination panel.

Schematic and Physical Attributes: See Drawing 4501-464.

Field Wiring: 50-position terminal blocks with screw clamps. Wire range 12 to 26 AWG.

Connections to AVME9630/9660: P1, 50-pin male header with strain relief ejectors. Use Acromag 5025-550-x or 5025-551-x cable to connect panel to VME board. Keep cable as short as possible to reduce noise and power loss.

Mounting: Termination panel is snapped on the DIN mounting rail.

Printed Circuit Board: Military grade FR-4 epoxy glass circuit board, 0.063 inches thick.

Operating Temperature: -40°C to +100°C.

Storage Temperature: -40°C to +100°C.

Shipping Weight: 1.25 pounds (0.6kg) packed.

TRANSITION MODULE: MODEL TRANS-GP

Type: Transition module for AVME9630/9660 boards.

Application: To repeat field I/O signals of IP modules A through D for rear exit from VME card cages. This module is available for use in card cages which provide rear exit for I/O connections via transition modules (transition modules can only be used in card cages specifically designed for them). It is a double-height (6U), single-slot module with front panel hardware adhering to the VMEbus mechanical dimensions, except for shorter printed circuit board depth. Connects to Acromag termination panel 5025-552 from the rear of the card cage, and to AVME9630/9660 boards within card cage, via flat 50-pin ribbon cable (cable Model 5025-550-X or 5025-551-X).

Schematic and Physical Attributes: See Drawing 4501-465.

Field Wiring: 100-pin header (male) connectors (3M 3433-D303 or equivalent) employing long ejector latches and 30 micron gold in the mating area (per MIL-G-45204, Type II, Grade C).

Connects to Acromag termination panel 5025-552 from the rear of the card cage via flat 50-pin ribbon cable (cable Model 5025-550-X or 5025-551-X).

Connections to AVME9630/9660: 50-pin header (male) connectors (3M 3433-1302 or equivalent) employing long ejector latches and 30 micron gold in the mating area (per MIL-G-45204, Type II, Grade C). Connects to AVME9630/9660 boards within the card cage via flat 50-pin ribbon cable (cable Model 5025-550-X or 5025-551-X). Transition module is inserted into a 6U-size, single-width slot at the rear of the VMEbus card cage.

Mounting: Transition module is inserted into a 6U-size, single-width slot at the rear of the VMEbus card cage.

Printed Circuit Board: Six-layer, military-grade FR-4 epoxy glass circuit board, 0.063 inches thick.

Operating Temperature: -40°C to +85°C.

Storage Temperature: -55°C to +105°C.

Shipping Weight: 1.25 pounds (0.6Kg) packed.

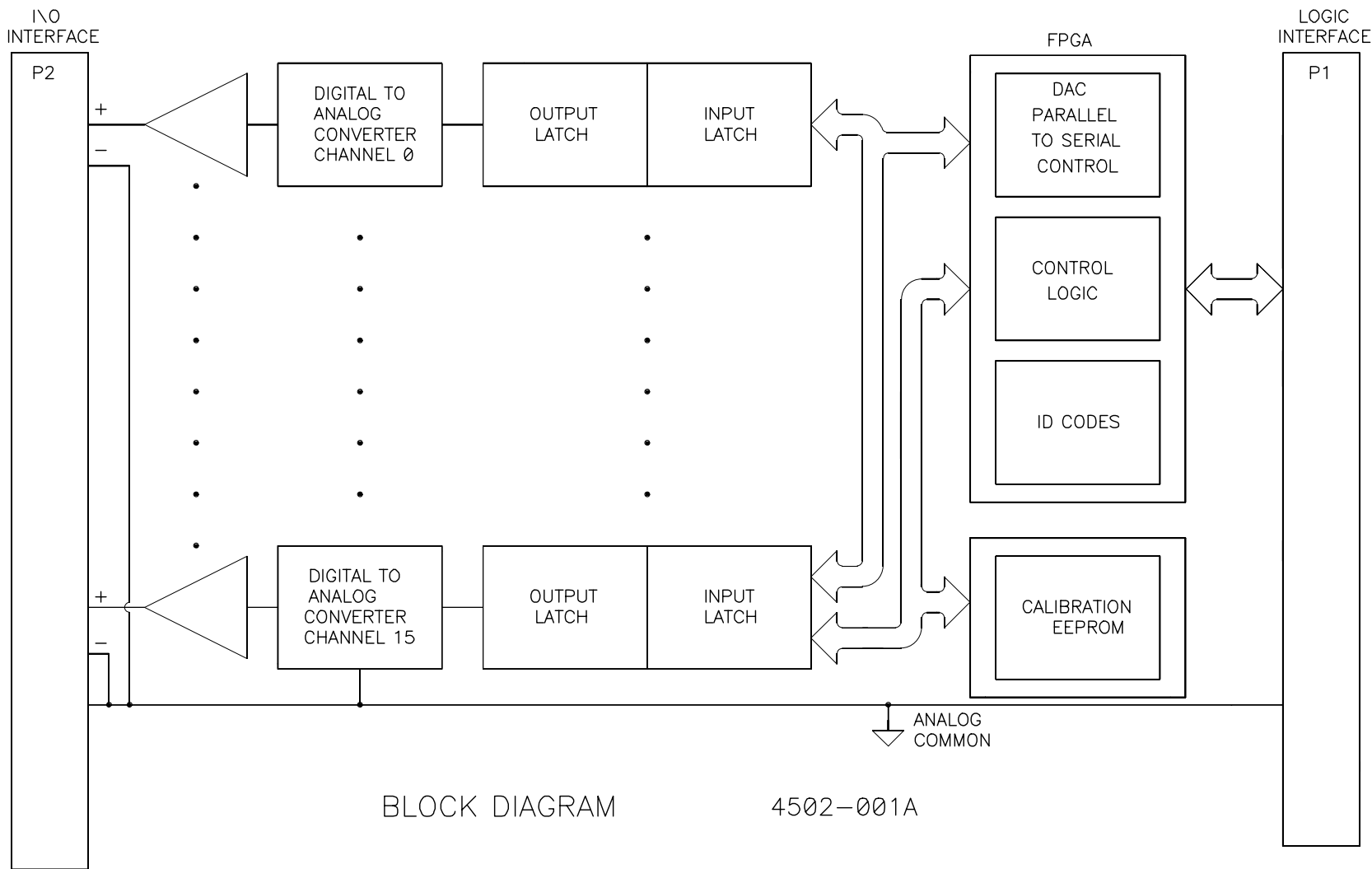

BLOCK DIAGRAM

4502-001A

NOTE: ALL 16 CHANNELS ARE REFERENCED TO ANALOG GROUND.
TO AVOID GROUND LOOPS, DO NOT CONNECT GROUNDED
LOADS TO THE NEGATIVE SIDE OF THE OUTPUT.

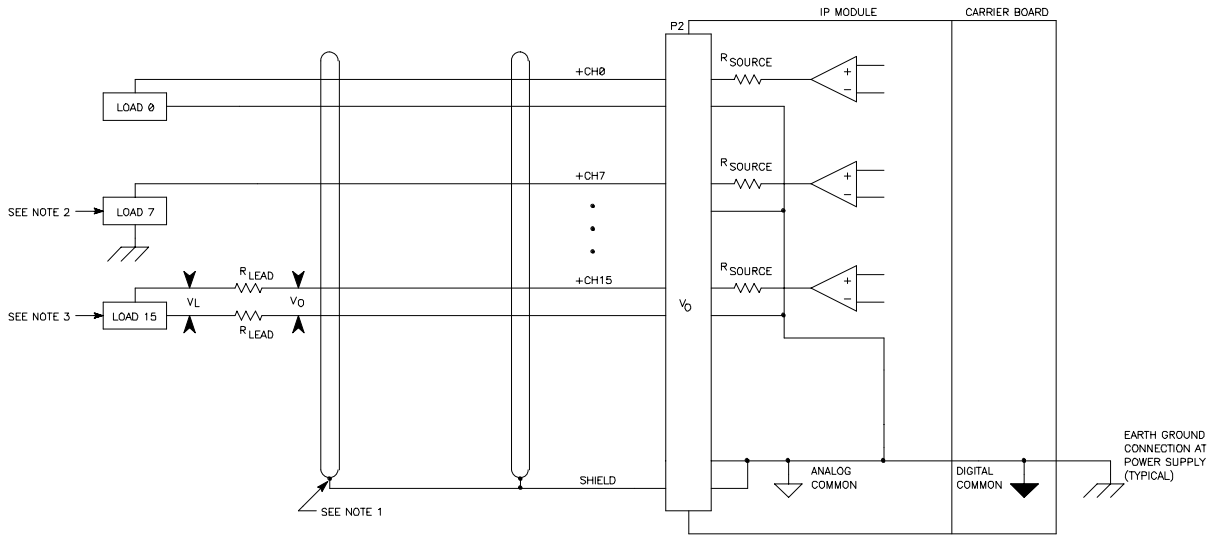

- NOTES:
1. SHIELDED CABLE IS RECOMMENDED FOR LOWEST NOISE. SHIELD IS CONNECTED TO GROUND REFERENCE AT ONLY ONE END TO PROVIDE SHIELDING WITHOUT GROUND LOOPS.
 2. ALL 16 CHANNELS ARE REFERENCED TO ANALOG COMMON AT THE IP MODULE. TO AVOID GROUND LOOPS, DO NOT CONNECT GROUNDED CHANNELS TO THE NEGATIVE SIDE OF THE OUTPUT.
 3. $V_L < V_O$ DUE TO VOLTAGE DROPS ACROSS THE LEAD RESISTANCE OF THE WIRE. IT IS RECOMMENDED THAT A HIGH RESISTANCE LOAD WITH A SHORT WIRE RUN BE CONNECTED AT THE OUTPUT TO REDUCE THE EFFECTS OF LEAD AND SOURCE RESISTANCE VOLTAGE DROPS IN THE WIRE.

ANALOG OUTPUT CONNECTION DIAGRAM

4502-002A

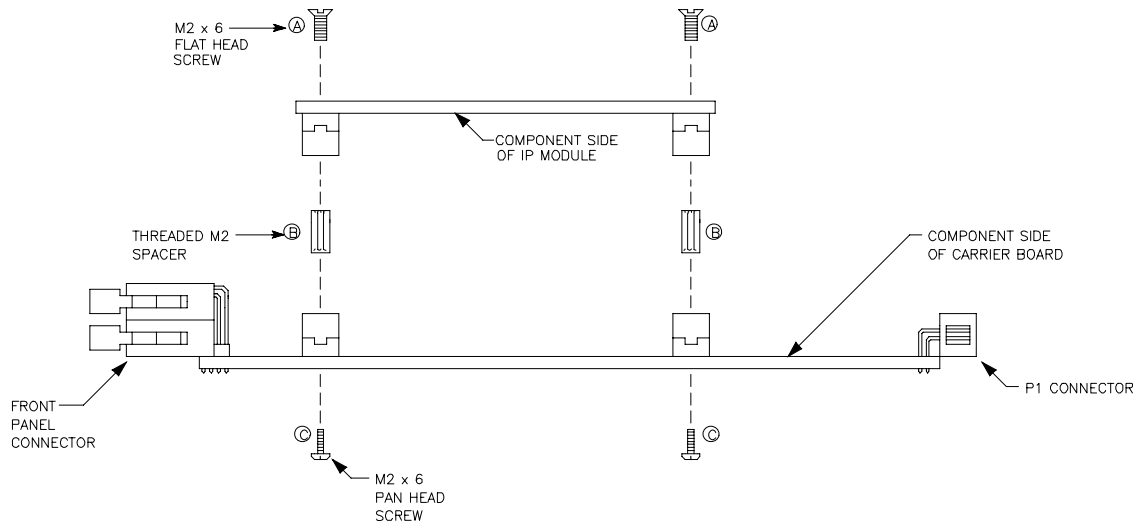

ASSEMBLY PROCEDURE:

1. THREADED SPACERS ARE PROVIDED IN TWO DIFFERENT LENGTHS. THE SHORTER LENGTH IS FOR USE WITH AVME 9630/9660 CARRIER BOARDS (SHOWN). CHECK YOUR CARRIER BOARD TO DETERMINE ITS REQUIREMENTS. MOUNTING HARDWARE PROVIDED MAY NOT BE COMPATIBLE WITH ALL TYPES OF CARRIER BOARDS.
2. INSERT FLAT HEAD SCREWS (ITEM A) THROUGH SOLDER SIDE OF IP MODULE AND INTO HEX SPACERS (ITEM B) AND TIGHTEN (4 PLACES) UNTIL HEX SPACER IS COMPLETELY SEATED.
3. CAREFULLY ALIGN IP MODULE TO CARRIER BOARD AND PRESS TOGETHER UNTIL CONNECTORS AND SPACERS ARE SEATED.
4. INSERT PAN HEAD SCREWS (ITEM C) THROUGH SOLDER SIDE OF CARRIER BOARD AND INTO HEX SPACERS (ITEM B) AND TIGHTEN (4 PLACES).

4501-434B

IP MODULE TO CARRIER BOARD MECHANICAL ASSEMBLY

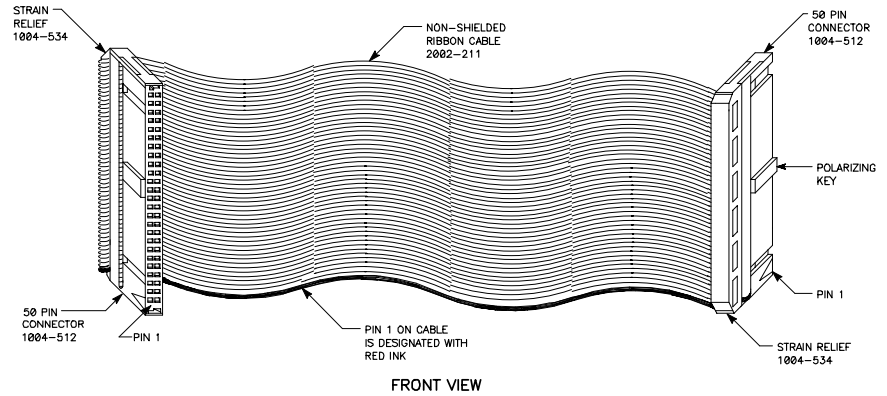
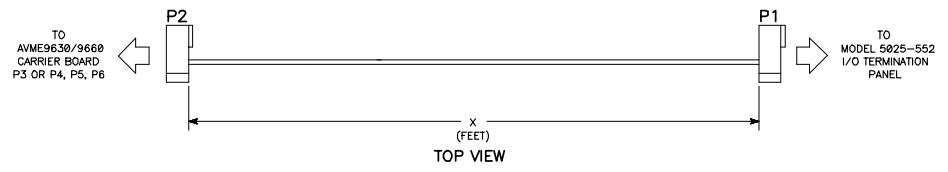
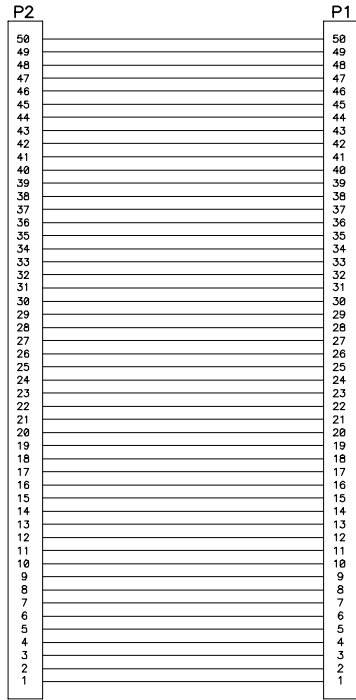

NOTE: SEVEN DIGIT PART NUMBERS ARE ACROMAG PART NUMBERS (XXXX-XXX).

4501-462A

MODEL 5025-550-x SCHEMATIC

MODEL 5025-550-x SIGNAL CABLE, NON-SHIELDED

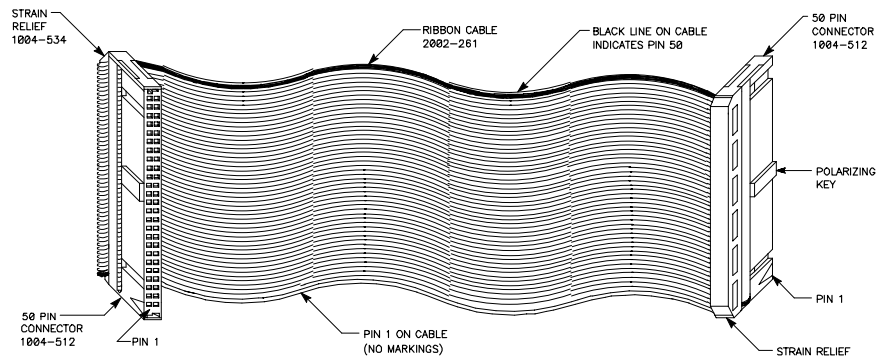
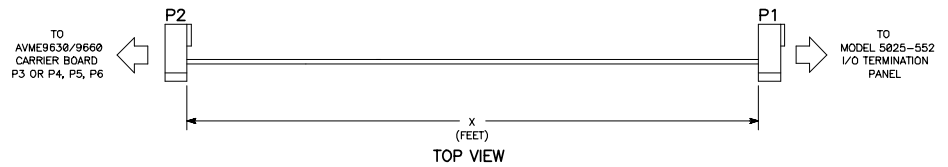
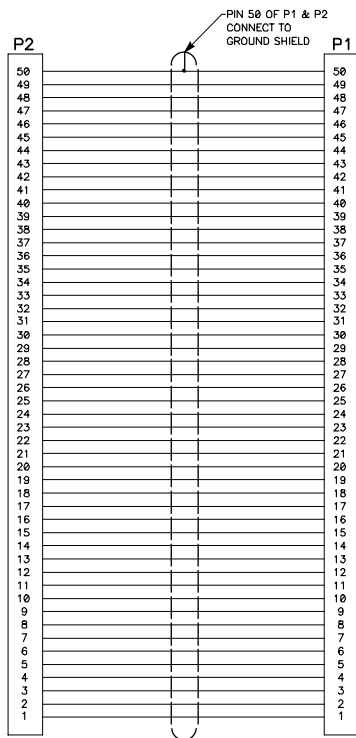

NOTE: SEVEN DIGIT PART NUMBERS ARE ACROMAG PART NUMBERS (XXXX-XXX).

4501-463A

MODEL 5025-551-x SCHEMATIC

MODEL 5025-551-x SIGNAL CABLE, SHIELDED

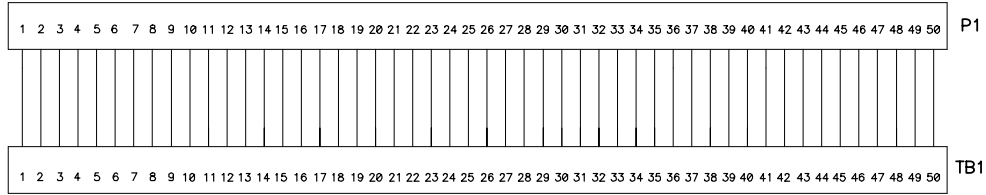

MODEL 5025-552 TERMINATION PANEL SCHEMATIC

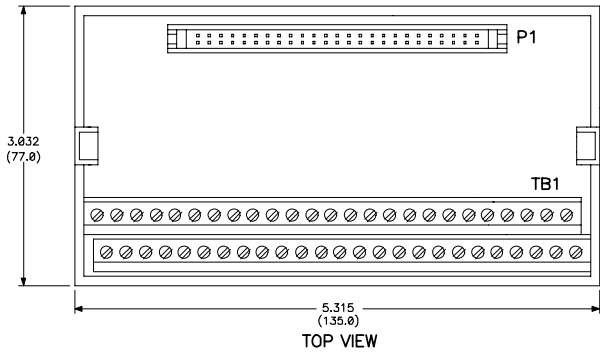

TOP VIEW

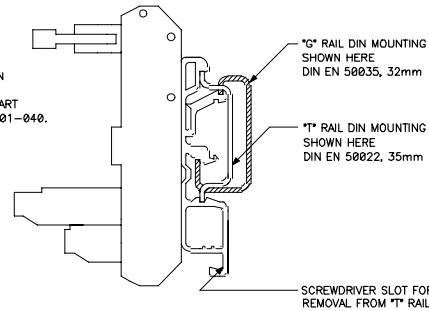

SIDE VIEW

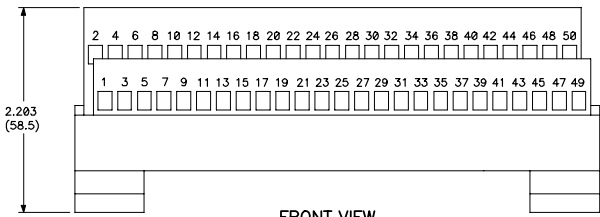

FRONT VIEW

4501-464A

NOTES:
DIMENSIONS ARE IN INCHES (MILLIMETERS).
TOLERANCE: ±0.020 (±0.5).

MODEL 5025-552 TERMINATION PANEL

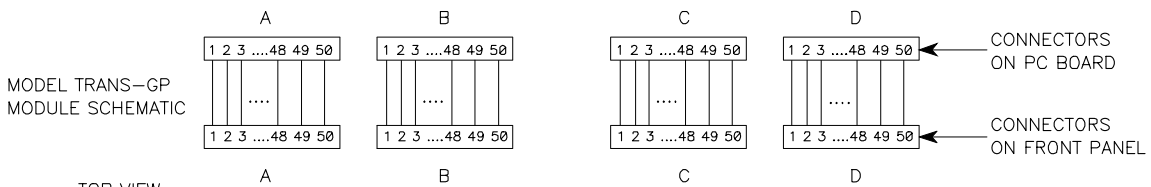

TOP VIEW

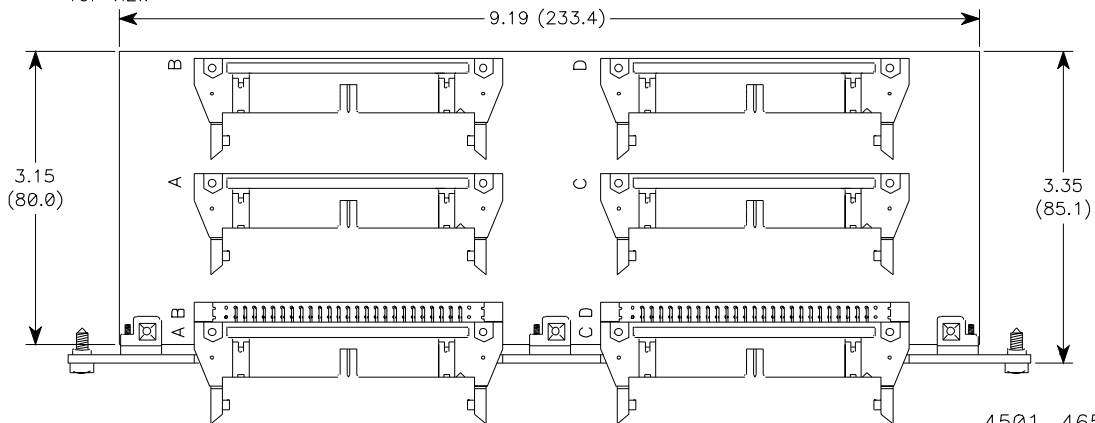

4501-465A

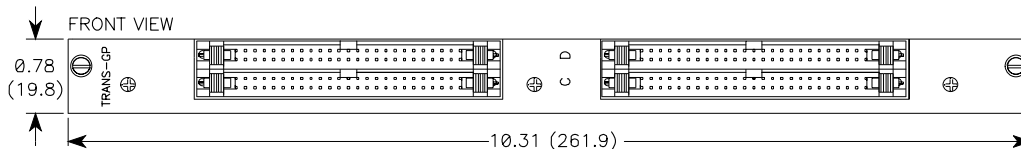

TRANS-GP MECHANICAL DIMENSIONS AND SIMPLIFIED SCHEMATIC

NOTE: DIMENSIONS ARE IN INCHES (MILLIMETERS).