

EXPERIMENTAL STUDY OF PULSED HEATING OF ELECTROMAGNETIC CAVITIES

D.P. Pritzkau, A. Menegat, and R.H. Siemann

Stanford Linear Accelerator Center, Stanford University, California 94309[†]

and T.G. Lee and D.U.L. Yu

DULY Research Inc., Rancho Palos Verdes, CA 90275^{††}

Abstract

An experiment to study the effects of pulsed heating in electromagnetic cavities will be performed. Pulsed heating is believed to be the limiting mechanism of high acceleration gradients at short wavelengths. A cylindrical cavity operated in the TE₀₁₁ mode at a frequency of 11.424 GHz will be used. A klystron will be used to supply a peak input power of 20 MW with a pulse length of 1.5 μ s. The temperature response of the cavity will be measured by a second waveguide designed to excite a TE₀₁₂ mode in the cavity with a low-power CW signal at a frequency of 17.8 GHz. The relevant theory of pulsed heating will be discussed and the results from cold-testing the structure will be presented.

1 INTRODUCTION

Pulsed heating will place a limit on the surface magnetic field in electromagnetic cavities due to thermal stress and through it a constraint on the maximum acceleration gradient possible for future linear colliders. A similar limitation has been encountered in optics for short pulse CO₂ lasers[1], and based on these results we expect the essential problem to be the low yield strength of materials such as fully annealed OFE copper. Different materials such as glidcop[®] with much higher yield strengths must be investigated. The purpose of the proposed experiment is to test several different materials under high power RF. The first set of experiments will test OFE copper.

2 BACKGROUND

Pulsed heating arises from the instantaneous local power dissipation at the surface of the metal due to the surface magnetic field and the surface resistance of the material. Ignoring radiation effects, the heat deposited at the surface of the metal must flow into the material inducing stress in the lateral dimensions through thermal expansion. Heat flow is governed by the heat diffusion equation knowing the metal's specific heat and thermal conductivity. It is found that the maximum temperature rise occurs at the surface of the metal.

The temperature rise scales as

$$\Delta T \propto \sqrt{\frac{fT_p}{\sigma c_e k}}$$

where f is the RF frequency, T_p is the RF pulse length, σ is the electrical conductivity, c_e is the specific heat at constant strain and k is the thermal conductivity.

Based on the considerations of thermal stress due to pulsed heating, the threshold for plastic deformation is[1]

$$\Delta T_y = \frac{(1-\nu)Y}{\alpha E}$$

where ν is Poisson's ratio, Y is the yield strength, α is the coefficient of linear expansion, and E is Young's modulus. Surface roughening and fatigue cracks are expected to appear for temperature rises of $\Delta T > 2\Delta T_y$ [1]. For fully annealed OFE copper this temperature rise corresponds to 40 °K and for glidcop 240 °K. However, there have been reports of substantially higher temperature rises in RF cavities[2] which suggest that this surface damage does not affect RF performance.

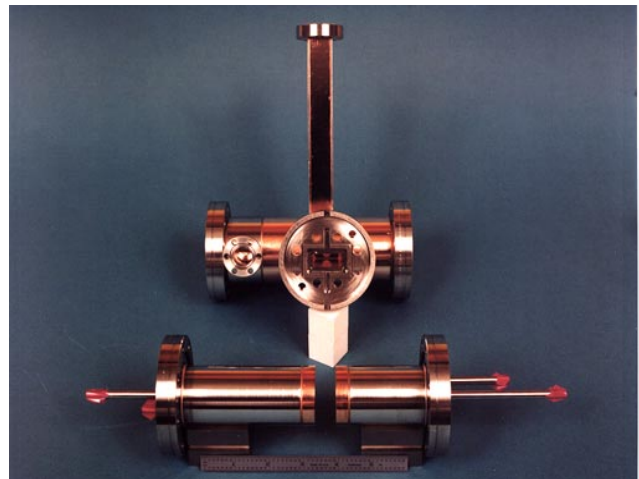

Fig. 1: Picture of test cavity with the endcaps outside. The actual length of the cavity is pictured. The water tubes can be seen at the end of the cylinders.

3 EXPERIMENTAL SETUP

The experiment will consist of two cylindrical cavities connected to a 50 MW X-band klystron through an asymmetric magic tee. The cavities will be operated under high power in the TE₀₁₁ mode at 11.424 GHz. Each

[†] Work supported by Department of Energy contract DE-AC03-76SF00515

^{††} Work supported in part by U.S. DOE SBIR grant number DE-FG03-96ER82213

cavity has a radius of 2.21 cm and an axial length of 1.9 cm. These dimensions were chosen to maximize the heating at the endcaps while keeping the heating along the cylindrical wall as small as possible. The endcaps are designed to be removable so that different materials may be used in future experiments. This design also allows the use of optical and electron microscopes to examine the surface. An annular gap of 1.0 mm exists between the endcaps and the cylindrical wall to remove the degeneracy of the TM_{111} mode and to facilitate vacuum pumping. One such cavity is shown in Fig. 1.

The copper endcaps are brazed onto long cylinders because the width of the WR-90 coupling waveguide is longer than the axial length of the cavity. Since the endcaps will receive the most heating, the cylinders were made hollow to allow water-cooling.

In this particular experiment the local temperature rise will be inferred by measuring the change in the wall Q of the cavity as well as the change in its resonant frequency during the length of a pulse. A second port designed to perform this measurement will excite a steady-state TE_{012} mode in the cavity at 17.8 GHz. The waveguide at the second port near the cavity has a width of a WR-42 waveguide and a height of a WR-62 waveguide. At this point the waveguide is cutoff from 11.4 GHz and no power will propagate from the TE_{011} mode. The waveguide is tapered to a full WR-62 after a length of 10 cm in which 11.4 GHz is attenuated by 150 dB. The taper is required to allow the use of available vacuum windows for WR-62 at 17.8 GHz. A schematic of the diagnostic setup is shown in Fig. 2. In the future a more direct way of measuring the local temperature rise along the surface of the endcaps will be devised.

A third cavity will function as a control that will not receive high power. After a high power run is performed with the other two cavities, the endcaps will be removed and tested in the third cavity. This test will isolate the RF properties of the endcaps.

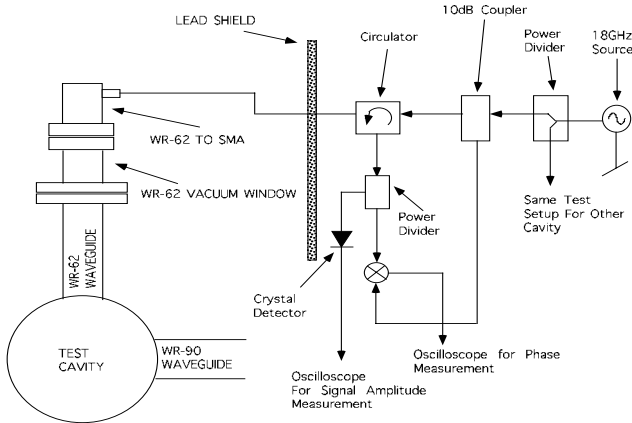

Fig. 2: Diagram of diagnostic setup

4 THEORY

A realistic assessment of pulsed temperature rise requires the temperature dependence of the specific heat, thermal conductivity and surface resistance of the material. For pure copper, this data can be found in

references[3],[4]. Hence, an integral equation for the local temperature rise at the surface is developed

$$\Delta T(\vec{x}, t) = \frac{1}{2\sqrt{\pi\rho}} \int_0^t \frac{dt'}{\sqrt{t-t'}} \frac{R_s(\Delta T) |H_{\parallel}(\vec{x}, t', \Delta T)|^2}{\sqrt{c_{\epsilon}(\Delta T)k(\Delta T)}}$$

where \vec{x} is the position along the surface of the cavity, ρ is the density and R_s is the surface resistance. The specific heat at constant strain is approximated as the specific heat at constant volume. The surface magnetic field is found from a differential equation that governs a cavity-waveguide coupled system. The result for the temperature distribution along the surface of the cavity at the end of a pulse is given in Fig. 3. The maximum temperature rise in the cavity is predicted to be approximately 350°K. The time evolution of the maximum temperature rise over the course of a pulse is shown in Fig. 4.

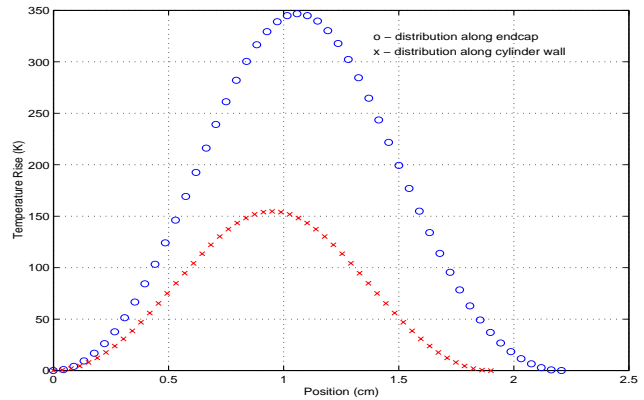

Fig. 3: Instantaneous temperature along the surface of the cavity after a 1.5 μ s, 20 MW pulse

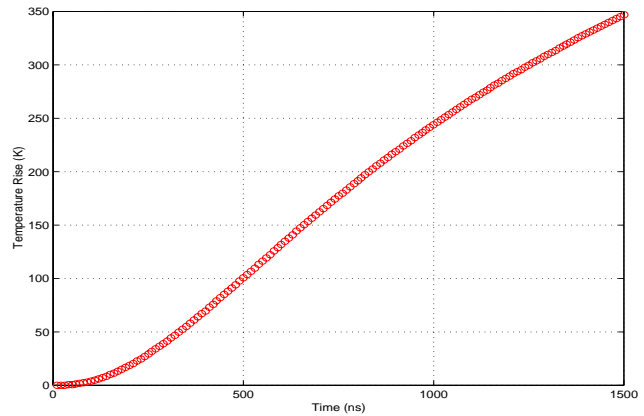

Fig. 4: The point of maximum temperature rise on endcap over the course of a pulse for 20 MW incident power

Since the surface resistance changes with temperature, the wall Q of the cavity will also be temperature dependent. A measurement of the wall Q will provide information on the global temperature rise in the cavity. The global temperature rise is just the weighted average of the local temperature changes over

the surface of the cavity. The temperature rise at a local point will be inferred by comparison with theory.

It is necessary to measure the Q as a function of time during a high-power pulse. The measurement becomes complicated if it is conducted on the same high power line at the fundamental mode frequency. For this reason a steady-state TE_{012} mode will be driven by a CW low-power source. Refer to Fig. 2. The coupling of this measurement port will change as the wall Q of the cavity changes. The amplitude and phase of the reflected power will be measured. Initially the port will be matched to the cavity and there will be no reflected power. A phase shift will occur due to the change in resonant frequency of the cavity during a pulse. Fig. 5 shows the expected amount of reflected power over time and Fig. 6 shows the expected phase shift over time. There are plans to calibrate this measurement.

The equation for the temperature rise in the cavity is based on a one-dimensional analysis. This equation does not account for structure in the lateral dimensions. This equation also does not take into account the effect of acoustic waves. Acoustic waves set up in the metal by pulsed heating can lead to damage even at low temperature rises[5]. More study of this part of the phenomenon of pulsed heating needs to be done.

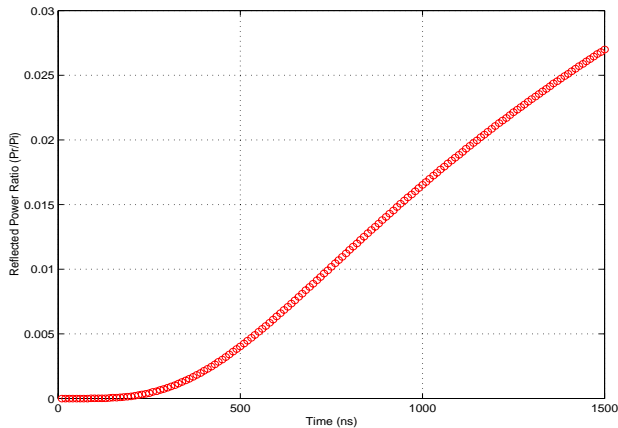

Fig. 5: Reflected power for TE_{012} mode over the course of a pulse

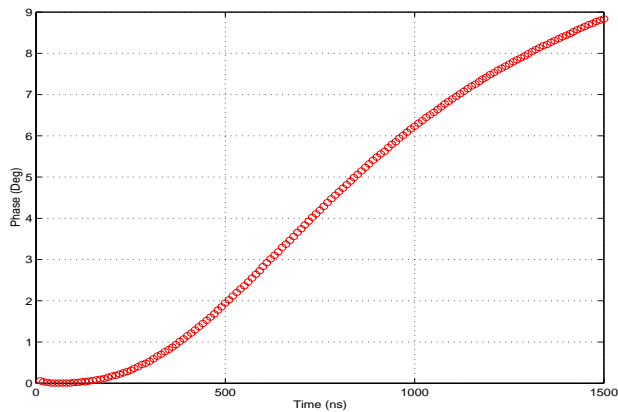

Fig. 6: Phase shift of reflected power for TE_{012} mode over the course of a pulse

5 RESULTS OF COLD-TEST

The cavities were designed with an axial length shorter than necessary so that they may be tuned by machining the endcaps. The sensitivity of the TE_{011} mode for these cavities is 7 MHz for every 25 μm that is machined off an endcap. The bandwidth of these cavities is approximately 1 MHz, so the final tuning procedure will involve varying how much the copper gaskets in the vacuum flanges will be crushed. Vacuum loading and water pressure from cooling must also be taken into account and is found to increase the frequency of the TE_{011} mode by approximately 10 MHz.

The coupling of the WR-90 waveguide to the TE_{011} mode is close to the design value of $\beta=1.2$ chosen to optimize the heating in the cavity. While determining the coupling to the TE_{012} mode, it was discovered that a coaxial mode was set up in the long gaps between the cylinders and the cavity inner surface. This coaxial mode caused a low-Q mode to overlap the high-Q TE_{012} mode. This problem has been solved using finger stock on the long cylinder to short out the coaxial mode. Since the TE_{012} mode is operated under low power, a slide-screw tuner will be used to match the WR-42/WR-62 waveguide to the cavity.

6 STATUS AND FUTURE PLANS

The cold-test measurements on the structures are almost complete. We expect to run at high power within a month.

7 ACKNOWLEDGEMENTS

The authors wish to acknowledge Prof. S. Schultz of UCSD for his idea of using a second mode to measure the change in the Q of the cavity. The authors also wish to thank G. Bowden, K. Ko, N.M. Kroll, and C.K. Ng for many helpful discussions.

REFERENCES

- [1] H.M. Musal, Jr., Laser Induced Damage in Optical Materials 1979, Nat. Bur. Standards Spec. Pub 568, 159, 1980.
- [2] J. Wang and T. Chen, private communication
- [3] Furukawa et al., American Institute of Physics Handbook, 3rd ed., "Heat Capacities", 1972
- [4] D.R. Lide, editor, Handbook of Chemistry and Physics, 77th ed., 1996-1997
- [5] Dieter Walz, private communication