

The International Linear Collider

Progress Report

2015

Linear Collider Collaboration

Editors

L. Evans and A. Yamamoto

15 July, 2015

Table of Contents

1. INTRODUCTION	1
2. ILC, POST-GDE ORGANISATION	2
3. THE PREFERRED SITE	3
4. GEOLOGICAL SURVEY AND CIVIL ENGINEERING STUDIES	4
5. ACCELERATOR HARDWARE DESIGN AND DEVELOPMENT, UPDATES	5
5.1 SRF CAVITY/CRYOMODULE DESIGN AND INTERGRATION	5
5.2 RF POWER SYSTEM: INDUSTRIALIZATION OF KLYSTRON MODULATORS	6
6. LAYOUT UPDATES FOR ACCELERATOR/ASSOCIATED SYSTEMS	7
6.1 FINAL FOCUS LAYOUT	7
6.2 POSITRON PRODUCTION	7
6.3 CRYOGENIC SYSTEM	7
7. INTERGRATION AND TEST AND FACILITIES	8
7.1 SLAC, FERMILAB AND JEFFERSON LAB (US)	8
7.4 DESY (GERMANY)	9
7.5 CEA-IRFU AND CNRS-LAL (FRANCE)	9
7.6 IHEP AND PEKING UNIVERSITY (CHINA)	10
7.7 RRCAT AND IUAC (INDIA)	10
7.7 KEK (JAPAN)	11
8. THE SCALE OF A HUB LABORATORY FOR CRYOMODULE PRODUCTION	12
9. PROJECT IMPLEMENTATION PLAN	13
10. FURTHER PREPARATORY WORK	13
10.1 GENERAL	13
10.2 SRF TECHNOLOGY	13
10.3 RF POWER SYSTEM: MODULATOR INDUSTRIALISATION	14
10.4 TEST/QUALIFICATION INFRASTRUCTURE AT KEK	14
10.5 NANO-BEAM TECHNOLOGY	14
10.6 POSITRON PRODUCTION	14
11. SUMMARY	15

1. Introduction

The International Committee for Future Accelerators (ICFA) set up the Global Design Effort (GDE) for the design of the International Linear Collider (ILC) in 2005 [1]. Drawing on the resources of over 300 national laboratories, universities and institutes worldwide, the GDE produced a Reference Design Report in 2007 [2], followed by a more detailed Technical Design Report (TDR) in 2013 [3]. Following this report, the GDE was disbanded. A compact core team, the Linear Collider Collaboration (LCC), replaced it [4]. This is still under the auspices of ICFA and is directly overseen by the Linear Collider Board, which reports to ICFA. The LCC is charged with continuing the design effort on a much-reduced scale until the Project is approved for construction. An additional mandate of the LCC was to bring together all linear collider work, including the CERN-based Compact Linear Collider (CLIC) [5] under one structure in order to exploit synergies between the two studies, as the organization structure is shown in Fig. 1.

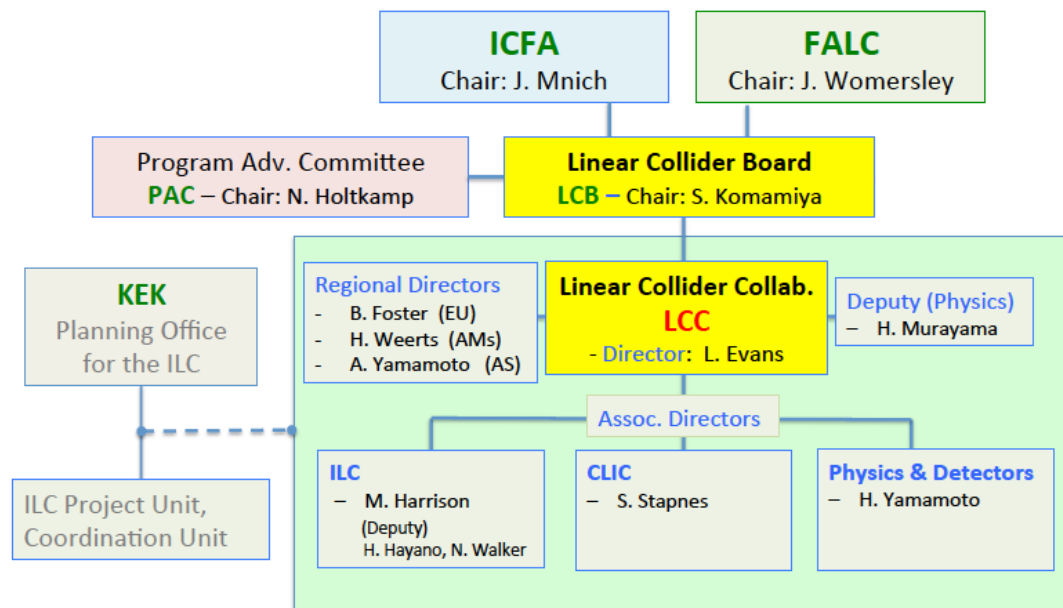

Figure 1. Structure of the Linear Collider Collaboration

For the ILC, an internal planning office at KEK has been established since early 2014 to prepare the transition from a study to an approved project [6].

The LCC has been organizing Linear Collider Collaboration Workshops twice a year since 2013, and the general activities and progress reports are available online/URL [7-11]. The LCB has recently requested a technical review by the LCC Program Advisory Committee (PAC), and the most recent activity reports presented to the review are also available online/URL [12].

2. ILC, Post-GDE organisation and activities

Much of the work of the LCC since 2013 has been to set up a provisional project structure to take forward the detailed site-specific design with a model site. The LCC has made use of several facilities around the world to make some progress, within the limit of available resources, in validating performance specifications and reducing component cost.

The structure of the collaboration specifically devoted to the ILC machine activities relevant to this report is summarized in Table 1 [13]. Until Project approval it is inevitably a collaboration based on good will and best effort rather than a strictly hierarchical structure. The sub-system leaders are located in laboratories around the world, although in view of the very strong Japanese involvement, all sub-systems have either a Japanese leader or deputy.

Although the ILC is not yet an approved project, formal project management procedures are already in place, including configuration management, strict change control, and entire records into the ILC Engineering Data Management System (ILC-EDMS) [14, 15]. This is an essential discipline to cope with the distributed nature of the available effort.

The Technical Design Report is quite specific in the choice of technologies but in the inevitable absence of a site choice it was forced to carry in parallel two quite different site topologies for the study, a flat site that was a likely choice in the USA or Europe, and a mountainous site such as that likely in Japan. Since then, the Japanese high-energy physics community has expressed interest in hosting the project so the design can converge on one single solution.

Table 1. ILC organization structure and sub-system responsibilities in 2015

LCC Associate Director responsible for ILC Accelerator: M. Harrison (BNL) - Deputies: H. Hayano (KEK) and N. Walker (DESY)			
Sub-System	<i>Global Leader - Deputy Leader</i>	Sub-System	<i>Global Leader - Deputy Leader</i>
ADI	N. Walker (DESY) - K. Yokoya (KEK)	SRF	H. Hayano (KEK) - C. Ginsburg (Fermilab) - E. Montesinos (CERN)
e-/e+ Sources	W. Gai (ANL) - M. Kuriki (Hiroshima)	RF Power & Cntl	S. Michizono (KEK) - TBD - TBD
Damping Ring	D. Rubin (Cornell) - N. Terunuma (KEK)	Cryogenics	H. Nakai (KEK) - D. Delikaris (CERN) - T. Peterson (Fermilab)
RTML	S. Kuroda (KEK) - A. Latina (CERN)	CFS	V. Kuchler (Fermilab) - J. Osborne (CERN) - M. Miyahara (KEK)
Main Linac	N. Solyak (Fermilab) - K. Kubo (KEK)	Radiation Safety	T. Sanami (KEK) - S. Roesler (CERN) - TBD
BDS	G. White (SLAC) - R. Tomas (CERN) - T. Okugi (KEK)		

3. The preferred site

A search for appropriate candidate sites for ILC construction in Japan has been on-going since 1999, with more than ten candidate sites announced in 2003. In 2010, the candidate site study was focused to two, Kitakami in Tohoku and Sefuri in Kyushu which both satisfied the basic requirements previously defined [16]. Next, the process was started to identify the preferred site. It was agreed that this should first be an internal process inside the high-energy physics community in Japan. A site evaluation committee of eight members was formed within the community in Japan, and a separate committee of sixteen technical experts was formed to give opinions on issues such as geological conditions, environmental impact and social infrastructure. The selection of Kitakami, as the preferred candidate site, was made in early July 2013 [17].

The conclusion was submitted to an international expert committee meeting at CERN on July 23-24th 2013 under the Chairmanship of the LCC Director. The methodology adopted to reach the preferred candidate site was first explained. The evaluation was made mainly in terms of mandatory requirements (geology, ground stability, vibration characteristics etc.) and on risk factors, which could increase the

cost. The committee was satisfied that this had been done in the most objective and scientific way possible.

The overall length of the proposed site is 50 km, which would allow the energy of the ILC to be increased from its initial design value of 500 GeV, which requires only 31 km, to the 1 TeV specified in the TDR. It consists of granite rock over 46 km with sedimentary rock in the southern 4 km. The proposed trajectory contains no active faults. The closest active fault is the western edge of the Kitakami lowland fault, which is 20 km away. The location of the tunnel is at higher altitude than the nearby rivers, allowing natural drainage of the underground structures. The committee agreed that the site is in good geological conditions for tunneling and stability with low seismic noise. It is very well suited for ILC construction. The preferred candidate site of Kitakami has been approved by the International expert committee and by the LCC collaboration [18].

4. Geological Survey and Civil engineering studies

Substantial geological survey and civil-engineering studies for the preferred candidate site have been made in collaboration with Tohoku University, Iwate Prefecture and KEK, including electrical power availability, ground-water conditions, environmental assessment, and general access. A 3-D map of the whole region has been made by an aerial laser survey using aircraft and satellite navigation. This has allowed the preliminary positioning of the access tunnels. The ILC power demand is about 1.5% of the total supply capacity of the Tohoku region. Integration of the ILC into the network infrastructure is being studied.

One important change from the design of the mountain site in the TDR is the access to the experimental cavern. In the original design, the cavern was deep underground and the only possibility of access was through long tunnels. By optimising the position of the ILC, the experimental cavern can be positioned at a point much closer to the surface, allowing the main access to be changed to vertical shafts, similar to ATLAS and CMS at CERN [19]. Before being accepted, this change was put through a rigorous change-control process in which all consequences of the change were documented before a final decision was made [20]. This new configuration is preferred by the experiments and is cost-neutral compared to the original version. Geological investigation of the new area of the experimental hall will now continue with in-kind contributions from Tohoku University and Iwate Prefecture.

A second important change going through the change-control procedure is the request to lengthen the main linac tunnel by approximately 1.5 km in each direction [21]. The motivation for this is two-fold. The first is to adjust the total beam-line path

length in order to fulfill the timing constraint required to ensure that positrons collide with electrons at the interaction point. The second is to give a sufficient reserve so that if it is not possible to achieve the required gradient of 31.5 MV/m over the whole cavity production, the ILC will still be able to operate at its design energy of 500 GeV by installing more cryomodules with minimum additional cost.

In order to keep this change cost-neutral, a second change in tunnel configuration is under study [22]. In the original design it was assumed that personnel access into the service tunnel would be needed at all times including machine operation with beam. As a consequence, a very thick (3.5m) shielding wall separating the linac from the service tunnel was included. The requirement of full access during beam operation is convenient but has never been a requirement in other machines; for example, at the Large Hadron Collider, access is forbidden during beam operation. Equipment reliability is now such that this requirement can also be dropped for the ILC. The shielding wall can be made much thinner, with only sufficient shielding against X-rays and neutrons during hardware commissioning including cavity conditioning when personnel access is required. The tunnel cross section can consequently be made smaller, reducing the cost. Once this change has passed fully through the change-control procedure, it will be integrated into the baseline design.

Finally, a collaboration agreement has been made between KEK, CERN and the civil engineering company ARUP to develop software for tunnel layout optimisation [23].

5. Accelerator hardware design and development, updates

Logically, the next step in the design would be “value engineering”, where the different systems are optimised to reduce cost. Available resources have allowed limited progress to be made in this area. The system that has received most attention is the superconducting RF (SRF) cavity/cryomodule design and integration [24].

5.1 SRF Cavity/Cryomodule design and integration

Superconducting material, cavity, and magnetic shield:

In the TDR, the cavities are constructed from rolled niobium sheet. Discussions with Niobium producers have opened up the possibility of replacing the rolled sheet with slices cut directly from ingots with a controlled grain size, giving a potential cost saving and better control of the surface cleanliness and mechanical stability [24 - 26].

Industrial cavity production has been closely followed through the European XFEL project, using the same SRF technology. More than 80 % of 800 SRF cavities have been manufactured by two European companies and tested at the DESY test facility (DESY-AMTF). The test results so far show an average usable gradient of 30 MV/m with the manufacturing and surface-treatment recipes (with the final EP process) specified in the ILC-TDR [27, 28].

Following experience from cavity-string assembly at the E-XFEL, it has been decided to place the magnetic shield inside the cavity helium containment vessel. This will give more reliable performance and easier assembly work, resulting in cost savings. The effectiveness of the internal magnetic shield has been verified with various experiments and analyses [29].

Cavity Integration with power couplers and tuners:

A critical and costly element is the cavity power coupler. An industrial consortium in Europe is fabricating the couplers for the E-XFEL and the conditioning process is being carried out at LAL-Orsay [30]. The coupler assembly work with the cavity-string and with the cryomodule is being carried out at CEA-Saclay. Based on the experience with the E-XFEL coupler fabrication and assembly, the coupler design is being reviewed in a collaboration between KEK, CEA, CERN and DESY with the objective of simplifying assembly during cryomodule integration. A new material for the ceramic window promises to be effective in lowering secondary electron emission and may contribute to lowering the coupler fabrication cost. The KEK-STF-type coupler design enables the coupler assembly within the cavity-string and further integration processes within the cryomodule to be simplified. It should also reduce the coupler cost. An updated KEK-STF type coupler using the new ceramic window and providing plug-compatibility with the E-XFEL (originally TTF-III) type coupler has been designed and fabricated in cooperation with CERN and KEK [31-33]. A test will be made soon by a collaboration of KEK and CERN.

Another critical item is the mechanical tuner. Three different tuner designs of (i) lever-arm, (ii) blade, and (iii) slide-jack types have been technically well demonstrated within the S1-Global program during the GDE-TDR phase [34]. In the next step after the TDR, the best cost-effective design has been investigated. Presently, an updated design of the lever-arm type tuner is in progress at Fermilab [35]. The design is very similar to the original lever-arm type tuner used for the E-XFEL cavity system, modified to fit the ILC cavity layout, which requires a design longitudinally shorter than that of the EXFEL. The adaptability of the modified lever-arm tuner design to the ILC-type cavity system is being studied in collaboration between FNAL, SLAC, CEA and KEK [36].

5.2 RF Power System: Industrialization of Klystron Modulators

An important update with respect to the TDR is the industrialisation of the Klystron modulators, based on the TDR design choice of a solid-state Marx generator which should be much more reliable and cost effective than conventional modulators [37]. This is an important element in the decision to change the access condition to not allow access during beam operation and to reduce the thickness of the shielding wall.

6. Layout updates for accelerator/associated systems

6.1 Final focus layout

In the TDR, the distance between the end of the final-doublet quadrupole and the interaction point was different for the two detectors. This poses a number of problems when exchanging the detectors. Discussion with the experimental collaborations has resulted in a compromise solution where this distance is the same for both detectors, and the design change has been formally concluded [38, 39].

6.2 Positron production

In the TDR, converting photons produced in a long undulator by the electron beam produces polarized positrons. The cooling for the converter target still needs substantial R&D. In addition, for very low-energy operation, the positron flux may not be sufficient. A backup scheme for positron production is under study using a conventional source, from which the positrons will not be polarised [40]. This must be made compatible with the TDR accelerator tunnel layout so that both options could be installed in the same tunnel [41].

6.3 Cryogenic system

Progress has also been made in the layout of the cryogenic system. After a comprehensive review in collaboration with those responsible for the cryogenics at the Large Hadron Collider [42], which has similar requirements and constraints, the configuration of the cryogenics system update is in progress [24, 43]. The helium compressors, the 4.5K refrigeration, and helium storage are to be moved to the surface to avoid underground cryogen storage for safety reasons and to reduce mechanical vibration from the compressors and cooling towers. The design change request process is being prepared.

7. Integration and Test and facilities

As a consequence of initiatives undertaken by the GDE and the construction of the E-XFEL, a number of facilities exist around the world that can be used to integrate and test cavities and cryomodules [44-49]. There are also a number of facilities where test beams are available and are being used to validate the ILC beam performance specification and to develop tools to allow this performance to be achieved [50-52]. The facilities available in each laboratory are discussed below.

7.1 SLAC, Fermilab, and Jefferson Lab (US)

The world's only operating linear collider was built at SLAC in the 1980's and considerable expertise still exists. The Facility for Advanced Accelerator Tests (FACET) [50], which uses part of the SLAC linear accelerator for beam-related research, has been used by the CERN linear collider group to test alignment and correction algorithms on real beams. Impressive progress has been made, with the techniques developed directly applicable to the ILC. Recently, a new free-electron-laser project, the Linear Coherent Light Source (LCLS II) has been approved for construction at SLAC [53]. The LCLS will use identical cavities to the ILC and has stimulated a strong and renewed interest in superconducting radio frequency in the US. This new project will strengthen the collaboration between the LCLS and ILC teams due to this common interest.

Fermilab has been a main laboratory for cavity and cryomodule development and hosted the GDE study. There is considerable expertise in superconducting RF, with a large infrastructure for cavity assembly and testing [47]. Recently a very important milestone was achieved when a full ILC cryomodule was powered to the nominal gradient of 31.5 MeV/m [54]. The approval of the LCLS has given a strong boost to the cavity effort at FNAL since half of the cryomodules for LCLS are to be assembled and tested there [55]. FNAL is anticipated to be the main hub laboratory for the production of the US contribution to the ILC.

Thomas Jefferson National Laboratory (JLAB) has been a centre of excellence for superconducting RF for many years with its own accelerator relying heavily on the technology [48]. It specialises in the chemical treatment that the cavities require to achieve the best performance [56]. JLAB was an important collaborator in the R&D during the GDE phase and processed the cavities that were assembled into the very successful cryomodule tested at FNAL. JLAB is collaborating with FNAL and SLAC in the LCLS construction, and has built up a powerful infrastructure for cavity processing, cryomodule assembly and their cold-performance tests, which can also be used for ILC construction.

7.4 DESY (Germany)

The German national laboratory, DESY in Hamburg, is the home of the European X-ray Free Electron Laser (XFEL) now under construction in cooperation with INFN-LASA, CEA-IRFU, CNRS-LAL, and other member institutions centred in Europe [57]. DESY has integrated outstanding SRF technology since the TESLA project study, and INFN-LASA has been contributing to the SRF cavity and cryomodule integration technology. XFEL is a project about 10 % the size of the ILC and thus represents a “prototype” of the ILC except that the required gradient of the cavities (24 MeV/m in accelerator operation) is less demanding. Cavity production is now at full rate in two companies [58]. After delivery to DESY for testing, they are shipped to CEA-Saclay (below) for assembly into complete cryomodules [59, 60]. The LCC has access to all data from the series production and is following cavity performance evolution very closely. There is also an agreement that an additional 24 cavities are built and extracted from the production to be given special treatment to improve their performance beyond the XFEL requirement [61].

DESY also has an operating Free Electron Laser Facility (FLASH) using superconducting cavities and cryomodules very similar to those of the ILC, with a record of very stable operation with the user beam availability of more than 95% to the expected user beam time [62]. Access to this facility for SRF experiments has to be limited since it mostly serves a user community requiring long-term and very stable operation. However, dedicated time when the facility can be operated at much higher beam current than required for the free electron laser is allocated periodically. A beam of 9 mA (the ILC specification) has been successfully demonstrated, validating an important parameter needed to achieve ILC design performance.

7.5 CEA-IRFU and CNRS-LAL (France)

The two French laboratories are collaborating with DESY on E-XFEL cryomodule production. CEA-IRFU is responsible for the cryomodule assembly [45, 59] and CNRS-LAL is responsible for the procurement and conditioning/qualification of couplers [46, 60]. CEA has a large infrastructure for assembling complete cryomodules from cavities supplied by DESY and couplers from LAL. An industrial contractor under the supervision of CEA runs this facility. The cryomodule production rate is now reaching one every 4 working days, that required from one of the “hub” laboratories that will be set up in each region during ILC production.

A consortium of DESY, CEA-Saclay and LAL-Orsay is anticipated to form a hub laboratory consortium for the European contribution of ILC cryomodules.

7.6 IHEP and Peking University (China)

The Institute of High Energy Physics, IHEP, in Beijing is rapidly progressing in R&D on SRF technology. IHEP has demonstrated TESLA-like and ILC type SRF cavity fabrication, in close collaboration with KEK and Fermilab. The integration of a pair of 9-cell cavities into a cryomodule is to be completed and tested soon [63]. A new SRF laboratory has been established with a cavity and cryomodule test facility including cryogenics system sufficient for the cryomodule test. IHEP is contributing to the ILC Accelerator Design and Integration (ADI), focusing on the beam parameter optimization and simulation work [64-66]. IHEP is also contributing to the production of the EXFEL SRF cryomodule cold-mass and vacuum vessel.

Peking University (PKU) is active in SRF R&D on ILC type SRF cavities [67]. Based on many years of development, ILC type 9-cell cavities using fine grain and large grain niobium material have been fabricated, and the performances are approaching the ILC specification in close cooperation with JLab [68]. Recently, stable operation of the DC-SRF photo-cathode injector has been demonstrated with a 3.5 cell SRF cavity, and a cryomodule with two 9-cell cavities has been fabricated. It will be installed into a beam facility at PKU, and will be tested [69].

7.7 RRCAT and IUAC (India)

The Raja Ramanna Centre for Advanced Technologies (RRCAT) in Indore, is establishing a large infrastructure for SRF cavity fabrication, processing and qualification [70]. A number of 1.3 GHz single-cell cavities, one 5-cell and a 9-cell cavity have been developed successfully in collaboration with Fermilab under the Indian Institutions- Fermilab Collaboration (IIFC) [71]. A large electron beam welding machine, chemical and thermal treatment facilities have been installed and made operational. A vertical test stand (VTS) facility, with a capacity to mount six 1.3 GHz, 9-cell cavities / two 650 MHz 5-cell cavities at 2 K has been commissioned. A large Horizontal Test Stand (HTS) facility has been designed and is under fabrication. RRCAT has also developed an innovative laser-welding technology for the niobium cavity fabrication, as an alternative to electron-beam welding [72]. Laser welding technique will have a potential for cost reduction in mass production of superconducting cavities.

Inter University Accelerator Centre (IUAC) in New Delhi, is progressing with the development of a superconducting linear accelerator based on niobium quarter wave resonator (QWR). The facility has now been completed and is being routinely used for experiments. In this project, the majority of the niobium resonators were built by the in-house fabrication facility of IUAC [73]. The fabrication facility of niobium QWR of IUAC

has integrated its experience, since 10 years ago, as the first niobium facility developed in India.

RRCAT and IUAC are collaborating contribute to construction of a High Intensity Superconducting Proton Accelerator (HISPA) also known as Proton Improvement Plan (PIP-II) at Fermilab under the framework of IIFC as described above. Presently, the R&D activities are going on in Fermilab and Indian institutions with the goal of joint preparation towards the construction of the accelerators for the respective domestic programs.

7.8 KEK (Japan)

The Japanese National Laboratory, KEK, in Tsukuba, is a key partner in the ILC effort. It contains a facility for full cavity and cryomodule fabrication, integration, and testing [49]. All of the technologies including cavity forming, electron-beam welding and chemical treatment are available and are invaluable for prototype work and also for technology transfer to industrial companies [74]. There is also a facility similar to those at FNAL and DESY for the testing complete cryomodules. A new hall has recently been constructed where a cryomodule assembly facility similar those that exist at CEA-Saclay for cryomodule assembly and DESY for tests can be installed [75].

KEK possesses another unique and invaluable facility, the Accelerator Test Facility (ATF) [52]. This facility, built up over many years, contains a damping ring capable of producing a very low emittance beam [76]. Special fast-pulsed magnets have been developed for the multi-bunch beam extraction from the dumping ring [77]. It will be also be essential for the ILC. The Final Focus Test Facility (ATF-II) is a beam line with sophisticated optics that simulates the ILC final focus where the beams are focused to a small spot at the collision point [78]. This is used for testing the sophisticated optical correction scheme, and for development of the instrumentation and feedback systems that will be needed for the ILC. Recently, the ATF-II has demonstrated a final focus beam size of 44 nm at a beam energy of 1.3 GeV, which translates to about 7 nm with the ILC beam energy of 250 GeV [79, 80]. The results are very promising. This facility benefits from a strong international collaboration. A new octupole lens is being constructed at CERN and will soon be shipped to KEK, which should allow the spot size to be further reduced.

KEK is also preparing for project approval, with a provisional Planning Office led by the Director General [6]. After project approval, this office will need to be re-organised to cope with the international nature of the project, and be well harmonised with the international collaboration currently coordinated by the LCC.

8. The scale of a hub laboratory for cryomodule production.

It is assumed that there will be at least 3 hub laboratories around the world producing complete cryomodules ready for installation [81]. The responsibilities of each hub laboratory will be the following:

- Reception and QA of Niobium raw material and dispatch to cavity manufacturers;
- Follow-up of cavity manufacturing;
- Cold tests of all cavities;
- Follow-up of coupler fabrication;
- Conditioning of couplers and delivery to cryomodule assembly firm;
- Follow-up of cryomodule assembly;
- Testing of complete cryomodules - the TDR assumes that 38% (5 % for the pre-series, and 33 % of the series production) will be tested cold;
- Maintain a data baseband documentation of the whole production;
- Packing and delivery of complete cryomodules ready for installation to the ILC site.

It is of interest to compare the ILC production rate for the case of 3 hub laboratories with that achieved for the E-XFEL, as summarized in Table 2.

Table 2. Comparison of E-XFEL production with ILC

	E-XFEL	ILC
Number of hubs	1	3
Production duration (weeks)	125	325
Cavities/hub-lab	800	6600
Cryomodules/hub-lab	100	617
Cryomodule production/week	0.8	1.9
Cavity tests/week	6.4	20.3
Cryomodule tests/week	0.8	0.72*

- Assuming 38% tested cold.

The human resources needed for E-XFEL production follow-up and testing (DESY, CEA-Saclay and LAL-Orsay combined) are discussed below.

Cavity production and testing of cavities and cryomodules at DESY requires 56 persons (FTE/year) on average and in-kind contribution from Poland (IFJ-PAN) about 26 persons [82]. Cryomodule assembly follow-up at CEA-Saclay requires about 12 persons (FTE/year) and industrial subcontractor of 34 persons [83]. It should be noted that the averaged cryomodule production/assembly rate has been reaching 1.25 module/week (one cryomodule / 4 days, as described above), since Jan. 2015, after

many months of efforts. It would support the ILC cryomodule assembly rate to be sufficiently reliable. Coupler follow-up and conditioning requires about 6 people [84].

For the ILC hub laboratory, the increased weekly rate would require more people, notably for cavity testing. Extrapolating from E-XFEL, it is estimated that 200 ~ 250 FTE/year (to be further studied) will be required, including dedicated administrative staff, for the SRF cavity and cryomodule preparation and qualification work, at a hub laboratory, before delivery to the ILC host laboratory.

9. Project Implementation Plan

The ILC Technical Design Report contained a chapter on the Project Implementation Planning (PIP). Since the publication of this document in 2012, there has been considerable progress with implementation of the ILC in a site in Japan as detailed elsewhere in this report. As a consequence of these new developments, a working group under the Chairmanship of Professor Brian Foster, European Director of the LCC, was set up by LCB to update and adapt the Project Implementation Plan to the new conditions. A new and comprehensive report dealing with issues such as governance, funding models, host responsibilities etc. is currently being reviewed by LCB. A preliminary copy of this report is available on request; the final version is expected by the summer of 2015 [85].

10. Further preparatory work

10.1 General

It is anticipated that preparation (with appropriate funding) for full production will take about 4 years. This will include further geological investigation, particularly in the region experimental cavern. It will also be wise to do a full environmental impact study as was done for the LHC in order to document the state of the environment before construction. Additional prototype work and value engineering to sustain/reduce cost will be necessary in the following areas.

10.2 SRF technology

Cutting niobium sheet from ingots promises to be cheaper and will result in a cleaner surface than the rolled sheet presently used, as discuss above [25]. Once preparation funds become available, this development will become a high priority. The on-going work on an improved tuner design based on E-XFEL experience must continue and prototypes must be demonstrated in close cooperation with the LCLS SRF cavity production also discusses above [35]. Value engineering on the coupler

design must be extended with the objective of cost reduction, including integration in the process of the cryomodule assembly.

It is also important to continue various efforts to reduce the cost of cavities and to further improve their performance, especially for a possible energy upgrade to 1 TeV. Important subjects to be studied are:

- hydro-forming of Nb seamless cylinders or of Cu seamless cylinders followed by surface coating with Nb or other advanced superconductor [86].
- high-gradient and high-Q realisation with advanced material and surface treatment/doping technology [61, 87-89].

Based on the experience with the E-XFEL cryomodule-qualification process, some degradation of cavity performance has been observed after assembly into cryomodules [90, 91]. This must be further studied to prevent degradation of cryomodule performance.

10.3 RF power system: Modulator industrialisation

Modulators provide the pulsed power to the klystrons in the main linac tunnel. Traditionally these contain gas/oil-filled switches, which have limited lifetime and reliability. Modern technology now allows these to be replaced by much more reliable solid-state components. However, the industrialisation of a modern prototype Marx generator based on solid-state components must still be demonstrated. KEK is progressing with the development of prototypes manufactured by local industry, in collaboration with SLAC [92].

10.4 Test/Qualification infrastructure at KEK

The existing bench for testing complete prototype cryomodules under high power in which a beam can be accelerated must be completed with the highest priority. The new assembly and cryogenic-test hall at KEK must be equipped with the entire infrastructure necessary for integrating full cryomodules and testing cavities and cryomodules to demonstrate the capability of series production rate.

10.5 Nano-beam technology

It is very important to demonstrate that the beam-spot size and stability required for the ILC can be achieved. The effort at the accelerator test facility (ATF) at KEK must be continued to achieve the technical goals of both the beam size and the stability at the final focus, providing sufficient operational margin.

10.6 Positron production

The positron source is challenging. Further effort must be put into the undulator-based design including the convertor target. In parallel an alternative design using conventional, electron-driven, means (which will exclude polarised positrons) must be pursued as a backup solution.

11. Summary

The ILC technical design is now being adapted to the preferred candidate site. Changes in layout are being managed by a rigorous change-control procedure.

Series production of cavities for the European XFEL has shown that cavities can be mass-produced in industry with a performance well above XFEL requirements and close to that needed for the ILC.

A number of technical developments are under way with a view to further reducing the ILC cost. This work must continue through the preparatory stage for ILC construction once resources become available. A summary of the design updates and of the further preparatory work needed is summarized in tabular form in the Appendix.

References

- [1] ILC Global Design Effort (GDE), URL available:
<http://www.linearcollider.org/ILC/GDE>
- [2] ILC Reference Design Report (RDR), URL available:
<http://www.linearcollider.org/ILC/Publications/Reference-Design-Report>
- [3] ILC Technical Design Report (TDR), URL available:
<http://www.linearcollider.org/ILC/Publications/Technical-Design-Report>
- [4] Linear Collider Collaboration (LCC), URL available:
<https://www.linearcollider.org>
- [5] CLIC conceptual design report, URL available
cern.ch/project---CLIC---CDR. (2012).
- [6] KEK Planning Office for the ILC, KEK News and LC Newsline 2014/02/06, online available:
<http://legacy.kek.jp/intra-e/info/2014/020617/>
<http://newsline.linearcollider.org/archive/2014/20140206.pdf>
- [7] European Linear Collider Workshop (ECFA LC2013), DESY (2013), URL available:
<http://lc2013.desy.de>
- [8] Int'l Workshop on Future Linear Colliders (LCWS13), Tokyo (2013), URL available:
<http://www.icepp.s.u---tokyo.ac.jp/lcws13/>
- [9] Americas Workshop on Linear Colliders (ALCW2014), Fermilab (2014), URL available:
<https://www.linearcollider.org/awlc14/>
- [10] Int'l Workshop on Future Linear Colliders (LCWS14), INN VINCA (2014), URL available:
<http://lcws14.vinca.rs/post---festum---lcws14/>
- [11] Asian Linear Collider Workshop (ALCW2015), KEK (2015), URL available:
<http://www-conf.kek.jp/alcw2015/>
- [12] LCC Program Advisory Committee Review (PAC), LAL-Orsay (2015), URL available:
<https://agenda.linearcollider.org/event/6715/>
- [13] M. Harrison, "LCC ILC accelerator report", ALCW2015, online available
<https://agenda.linearcollider.org/event/6557/session/13/contribution/13>
- [14] ILC-EDMS (2014), URL available (ID required):
<https://ilc---edms.desy.de/>
- [15] ILC Change Management, URL available:
<http://ilc.desy.de/cm/>

- ILC Change Requests Register, ILC---EDMS---D*01056505 (2015), URL available: <https://ilc---edmsdirect.desy.de/ilc---edmsdirect/item.jsp?edmsid=D00000001056505>
- [16] A. Yamamoto et al., (editors), "Study of the ILC Project Infrastructure design guidelines", KEK Report 2013---5 (2014), on line available: <http://ccdb5fs.kek.jp/tiff/2013/1324/1324005.pdf>
- [17] ILC Strategy Council Report (2013), URL available: <http://ilc-str.jp/topics/2013/08281826/>
- [18] L. Evans, "Linear Collider Status", reported in LCWS2013, DESY (2013), URL available: <http://agenda.linearcollider.org/event/6000/other-view?view=standard>
- [19] CR-0003, "Detector hall with vertical shaft access", ILC-CR-0003, ILC-EDMS, No. D*0108475 (2014), online available: <https://ilc-edmsdirect.desy.de/ilc-edmsdirect/file.jsp?edmsid=D00000001084745>
- [20] CR-0003, "Report by Change Review Panel", EDMS---ID D*01092735 (2015) online available: <https://ilc-edmsdirect.desy.de/ilc-edmsdirect/item.jsp?edmsid=D00000001092735>
<https://agenda.linearcollider.org/event/6557/session/7/?slotId=1#20150420>
- [21] CR-0004, "Extension of the electron and positron main linac tunnels approximately 1.5 km", ILC-CR-0004, ILC-EDMS No. D*01092915 (2014), online available: <https://ilc---edmsdirect.desy.de/ilc---edmsdirect/file.jsp?edmsid=D00000001092915>
<https://agenda.linearcollider.org/event/6557/session/7/?slotId=4#20150420>
- [22] V. Kuchler, CR in preparation, "Kamaboko tunnel cross section", ALCW2015, KEK (2015) URL available: .
<https://agenda.linearcollider.org/event/6557/timetable/#20150421>
- E. Paterson, "Availability consideration for reduced "Great Wall" width", ILC-ADI meeting, 2 July (2015), URL available: <https://agenda.linearcollider.org/event/6810/>
- [23] J. Osborne, "Tunnel Optimization Tool (TOT) development", discussed in FCC week, Washington, (2015), online available: <https://indico.cern.ch/event/340703/session/38/contribution/1>
- [24] A. Yamamoto and H. Hayano, "ILC SRF", LCC-PAC, LAL-Orsay (2015), online available: <https://agenda.linearcollider.org/event/6732/contribution/17/material/slides/5.pdf>
- [25] G Mineni, "SRF ingot niobium technology: past, present, and future prospect" TTC 2014 WG4, Tsukuba (2014): online available <https://indico.desy.de/sessionDisplay.py?sessionId=12&confId=10663#20141203>

- [26] H. Shimizu, "Single-cell cavity R&D in KEK", ALCW2015, KEK (2015), URL available:
<https://agenda.linearcollider.org/event/6557/session/8/?slotId=9#20150424>
- [27] S. Aderhold, "European XFEL cavity production", ALCW2015, KEK (2015),
<https://agenda.linearcollider.org/event/6557/session/8/?slotId=9#20150424>
- [28] N. Walker "XFEL cavity & module testing", LLC---PAC, LAL---Orsay (2014), online available:
<https://agenda.linearcollider.org/event/6715/contribution/8/material/slides/1.pdf>
- [29] M. Masuzawa et al. "Magnetic shielding", SRF2013, Paris, and ALCW2015, KEK, (2015),
online available:
<http://epaper.kek.jp/SRF2013/papers/weiod02.pdf>
<https://agenda.linearcollider.org/event/6557/session/8/contribution/211/material/slides/0.pdf>
- [30] W. Kaabi "Progress in EXFEL coupler conditioning at LAL", TTC---2014.
- [31] Y. Yamamoto "STF-type couplers plug-compatible with TTF3-type couplers",
<https://agenda.linearcollider.org/event/6557/session/8/contribution/213>
- [32] O. Yushiro et al., "Fabrication of STF-type couplers plug-compatible with TTF3-type couplers"
TTC2014, KEK (2014) online available:
<https://indico.desy.de/sessionDisplay.py?sessionId=15&confId=10663#20141204>
- [33] K. Iwamoto et al., "Study of low SEE co-efficient alumina for SRF power-coupler window"
TTC2014, KEK (2014), online available:
<https://indico.desy.de/sessionDisplay.py?sessionId=15&confId=10663#20141204>
- [34] S1-Global Report, KEK Report 2013-3 (2013), online available:
http://www-lib.kek.jp/cgi-bin/kiss_prepi.v8?KN=201324003&OF=8.
- [35] Y. Pischalnikov, "Development of LCLS-II tuner", TTC2014, KEK, (2014), online available.
<https://indico.desy.de/sessionDisplay.py?sessionId=15&confId=10663#20141204>
<https://agenda.linearcollider.org/event/6557/session/8/contribution/208>
- [36] SCRF cavity frequency tuners mini-workshop, CERN (2014), URL available:
<https://agenda.linearcollider.org/event/6486/>
- [37] M.A. Kemp, "Solid state Marx modulators for emerging applications", LINAC2012, Tel-Aviv,
online available:
<http://accelconf.web.cern.ch/AccelConf/LINAC2012/papers/we2a02.pdf>.
- [38] CR-0002, "Baseline optics to provide for a single FFS L* (QD0 Exit---IP distance)
optics configuration", EDMS No. D*01082495 (2014), online available:
<https://edmsdirect.desy.de/edmsdirect/file.jsp?edmsid=D00000001082495>
- [39] CR-0002, "Final report from CR-002 (Common L*) CRP,"
EDMS No. D*01100205 (2015), online available:

- <https://ilc---edmsdirect.desy.de/ilc---edmsdirect/file.jsp?edmsid=D00000001100205>
<https://agenda.linearcollider.org/event/6557/session/7/contribution/65>
- [40] T. Omori et al., "A conventional positron source for international linear collider", Nuclear Instruments and Methods in Physics Research A672 (2012) 52---56,
 T. Omori, "Overview of electron driven positron source", LCWS2014, INN VINCO (2014),
<http://agenda.linearcollider.org/event/6389/session/9/?slotId=5#20141007>
 T. Omori, "Undulator---conventional footprint compatibility", ALCW2015, KEK (2015)
<https://agenda.linearcollider.org/event/6557/session/9/?slotId=8#20150423>
- [41] Change Request in preparation for the beam delivery system tunnel layout.
- [42] Mini-workshop on the ILC cryogenics and He inventory, CERN (2014), URL available:
<https://indico.cern.ch/event/325451/timetable/#20140618>
- [43] H. Nakai, D. Delikaris, and T. Peterson, "Cryogenics layout update", CR in preparation.
<https://drive.google.com/folderview?id=0B8kGudtgeo5iMIVxdTJZHpkVG8&usp=sharing&tid=0B8kGudtgeo5icDc2ZlJzb1V4Rmc>
[H. Nakai, D. Delikaris, and T. Peterson, "ILC Cry-System", Workshop URL-available:
 https://agenda.linearcollider.org/event/6779/](https://agenda.linearcollider.org/event/6779/)
- [44] M. Wiecek, "XFEL module test infrastructure and procedure at DESY", TTC---2014, KEK (2014),
 URL available: <https://indico.desy.de/sessionDisplay.py?sessionId=9&confId=10663#20141202>
- [45] O. Napoli, "Assembly experience from large scale CM production", LLC---PAC, LAL---Orsay
 online available:
<https://agenda.linearcollider.org/event/6715/contribution/8/material/slides/2.pdf>
- [46] W. Kaabi, "Challenge for mass---production of E---XFEL in put coupler", TTC2014, KEK (2014)
<https://indico.desy.de/contributionDisplay.py?contribId=4&confId=10663>
- [47] Fermilab Advanced Superconducting Test Accelerator, URL available:
<http://asta.fnal.gov>
- [48] SRF Institute at Jefferson Lab, URL available:
<https://srf.jlab.org/srf/HomeTab/vta.htm>
- [49] H. Hayano, "New SRF Facility at KEK", LCWS2014, Belgrade, (2014), online available.
<http://agenda.linearcollider.org/event/6389/session/11/contribution/183>
- [50] Facility for Advanced Accelerator Experimental Test (FACET) and Test Beam Facilities,
 URL available: ,
<https://www6.slac.stanford.edu/facilities/facet.aspx>
- [51] Free Electron Laser (FLASH) at DESY, URL available:
<http://flash.desy.de>

- [52] Accelerator Test Facility (ATF) at KEK, URL available:
<http://www---atf.kek.jp/atf/>
- [53] Linac Coherent Light Source (LCLS) LL at SLAC.
https://portal.slac.stanford.edu/sites/lcls_public/lcls_ii/Pages/default.aspx
- [54] E. Harms, "CM2 recent results", TTC2014, KEK (2014), online available:
<https://indico.desy.de/sessionDisplay.py?sessionId=9&confId=10663#20141202>
- [55] M. Ross, "LCLS cavity and cryomodule", discussed in KEK seminar, (2014).
- [56] R. Geng, "Characterization of control of foreign materials on post -- machined niobium surface" TTC2014, KEK (2014), URL available:
<https://indico.desy.de/sessionDisplay.py?sessionId=12&confId=10663#20141203>
- [57] M. Altarelli et al (eds) "XFEL: The European X---ray Free---Electron Laser, Technical Design Report," , DESY---06---097 (2006).
- [58] N. Walker et al, Cavity production and test progress, at DESY
 S. Aderhold, Update of E-FEL cavity production, ALCW2015, KEK (2015), online available:
<https://agenda.linearcollider.org/event/6557/session/8/contribution/214>
- [59] O. Napoli, "Update on the E-XFEL cryomodule production", ALCW2015, KEK (2015),
<https://agenda.linearcollider.org/event/6557/session/8/contribution/215>
- [60] W. Kaabi, "Challenge for mass production of E-XFE input couplers", TTC2014, KEK, (2014)
<https://indico.desy.de/conferenceTimeTable.py?confId=10663#20141202>
- [61] A. Navitski et al., ILC high-grade and SRF cavities R&D progress", ALCW2015, KEK (2015),
 online available:.
<https://agenda.linearcollider.org/event/6557/session/8/?slotId=8#20150424>
- [62] Free Electron Laser (FLASH) at DESY, (tentative) URL available:
<http://flash.desy.de>
- FLASH operation, DESY Accelerators 2014, Highlights and Annual Report, p18,
 Online available:
http://www.desy.de/sites2009/site_www---desy/content/e410/e84441/e173882/Accelerators_2014_Web_ger.pdf
- [63] J. Zhai et al., "ILC test cryomodule assembly", TTC2014, KEK
 (2014) URL available:
<https://indico.desy.de/sessionDisplay.py?sessionId=11&confId=10663#20141203>
- [64] J. Gao, et al., nal focus optics design (a talk entitled "Study of alternative ILC
 final focus _optical configurations" was given in LCWS 2014 Belgrade) .

online available:
LCWS2014, Belgrade.

- [65] D. Wang, P. Bambade, K. Yokoya, J. Gao, "Analytical estimation of ATF beam halo distribution", Chinese Physics C, Vol. 38, No. 12 (2014) 127003.
- [66] D. Wang, P. Bambade, Y. Wang, C. Rimbault, J. Gao, "Study of alternative ILC final focus optical configurations", NIMA, 781 (2015) p.14 - 19.
- [67] J.K. Hao et al., "Improving Gradient of 9 cell SRF cavities at Peking University", SRF2013, Paris, (2013), online available:
<http://accelconf.web.cern.ch/AccelConf/SRF2013/papers/thp011.pdf>
- [68] R. Geng, "High efficiency, high gradient cavities towards cutting down the ILC dynamic heat", ALCW2015, KEK (2015), URL available:
<https://indico.desy.de/sessionDisplay.py?sessionId=11&confId=10663#20141203>
- [69] K. Liu, "PKU SRF beam facility" in private communication..
- [70] S.C. Joshi et al., "Development of superconducting cavities and related infrastructure for high intensity proton linac for spallation neutron source", LINAC14, CERN, THPP122 (2014), online available:
<http://accelconf.web.cern.ch/AccelConf/LINAC2014/papers/thpp122.pdf>.
- [71] Project Report for the Joint Development of High Intensity Proton Accelerators at Fermilab, BARC and RRCAT, edited by Shekhar Mishra of FNAL, USA.
- [72] P. Khare et al., "Successful development of new fabrication technique using based on laser welding for SRF cavities – Results and path ahead", TTC2014, DESY (2014), URL available:
<https://indico.desy.de/sessionDisplay.py?sessionId=4&confId=9637#20140325>
- [73] D. Kajilal, "Development and operation of SRF resonators at IUAC, Delhi", TTC---2008, IUAC, (2008), URL available:
<https://indico.desy.de/conferenceOtherViews.py?view=standard&confId=946>
- [74] [74] M. Yamanaka, et al. "Cavity fabrication study in CFF at KEK", SRF2013, Paris (2013), THIOA03, online available:
<http://accelconf.web.cern.ch/AccelConf/SRF2013/papers/thioa03.pdf>
- [75] H. Hayano, KEK-STF-COI, in private communication.
- [76] Y. Honda, et.al., "Achievement of ultra-low emittance beam in the ATF damping ring", Phys. Rev. Lett. 92, 054802 (2004).
- [77] T. Naito et al., "Multibunch beam extraction using the strip---line kicker at KEK Accelerator Test Facility", Phys. Rev. ST Accel. Beams 14, 051002 (2011).
- [78] ATF---2 proposal, online available:
http://lcdev.kek.jp/ATF2/proposal/ATF2_proposal1.pdf

- [79] G. R. White, et al., “Experimental validation of a novel compact focusing scheme for future energy-frontier linear lepton colliders”, Phys. Rev. Lett., 112, 034802 (2014),
online available:
<http://journals.aps.org/prl/abstract/10.1103/PhysRevLett.112.034802>
- [80] K. Kubo et al., “Towards ILC: Experiments at ATF”, IPAC2015, Dresden, (2015),
online available:
<http://accelconf.web.cern.ch/AccelConf/IPAC2014/papers/weza01.pdf>
- [81] SRF hub-laboraty concept, proposed in ILC-TDR-Volume 3, Part1, p.76, URL
available: <http://www.linearcollider.org/ILC/Publications/Technical-Design-Report>
- [82] N. Walker, private communication for the DESY-AMTF manpower.
- [83] O. Napoli, private communication for the CEA-Saclay crymodule assembly manpower.
- [84] W. Kaabi et al., “Power couplers for XFEL”, IPAC2013, Shanghai, WEPW O001 (2013),
online available:
<http://accelconf.web.cern.ch/AccelConf/IPAC2013/papers/wepwo001.pdf>
- [85] ILC Project Implementation Plan, to be published as a LCC publication
- [86] M. Yamanaka et al., “Hydroforming SRF cavities from seamless NbTubes”,
TTC2014, KEK, (2014), online available:
<https://indico.desy.de/contributionDisplay.py?sessionId=12&contribId=87&confId=10663>
- [87] R. Geng, “High efficiency high gradient cavities towards cutting down the ILC dynamic heat load by a factor four”, ALCW2015, KEK (2015), online available:;
- [88] A. Grassellino et al, Supercond. Sci. Technol. **26** 102001 (2013)
(Rapid Communication) – highlights of 2013.
- [89] C. Reece, “Report from High-Q working group”, TTC2014, KEK (2014)
<https://indico.desy.de/sessionDisplay.py?sessionId=9&confId=10663#20141202>
- [90] D. Reschke, “XFEL cavity production tests and comparison before/after module assembly”,
TTC2014, KEK (2014), online available
<https://indico.desy.de/conferenceTimeTable.py?confId=10663#20141202>
- [91] N. Walker, “E-XFEL cavity vertical vs. module test statistics”, TTC2014, KEK (2014),
online available:
<https://indico.desy.de/sessionDisplay.py?sessionId=9&confId=10663#20141202>
- [92] M. Akemoto et al., “Present Status of ILC Klystronmodulator development at KEK”, Proc. Of
11th meeting of Particle Accelerator Society of Japan, Aomori, (2014), online available:
http://www.pasj.jp/web_publish/pasj2014/proceedings/PDF/MOOL/MOOL07.pdf

Appendix

Appendix 1:

-Table A1. Summary of the ILC design update and development in progress after TDR

Sect.	Category : -- Updates and the progress	Formal Actions made by the ILC CM Board
2	Post--GDE organization: -- The Linear Collider Collaboration (LCC) established, intending to bring the ILC project from “design to realisation”, after completion of the Technical Design Report (TDR) by the ILC Global Design Effort (GDE) in 2013.	
3	Candidate (model) site: -- Kitakami mountainous site in Japan identified as a preferred site by the Japanese High Energy Physics Community and approved by the LCC.	
4	Civil engineering studies: -- Detector hall access with vertical shafts -- ML tunnel length to be extended, 1.5 km each -- ML tunnel, central wall thickness to be thinner with no access to the accelerator tunnel in beam operation.	CR--0003 approved CR--0004 approved
5	Accelerator hardware design and development updates: <u>Accelerator design and integration:</u> -- Lattice design and luminosity parameters updated <u>SRF cavity and cryomodule:</u> -- Nb sheet sliced/cut directly from Nb ingot -- Cavity integration with improved lever--arm tuners, and STF-type couplers plug-compatible w/ TTF-III couplers <u>RF Power system:</u> -- Industrial production effort for Marx Generator in progress <u>Nano beam:</u> -- Achievement of a vertical beam spot size of 44 nm at KEK--ATF, corresponding to 7 nm at the ILC energy and close to the goal of 6 nm	CR--0005 approved
6	Layout updates for accelerator/associated systems: -- Final focus optics/layout with common L*, -- BDS tunnel design to accommodate both options of “undulator--type” and “conventional--type” - Cryogenics layout on surface	CR--0002, approved (CR in preparation) (CR in preparation)

8	<p>The size of a hub laboratory scoped for CM production: -- 3 hub laboratories is a model for the worldwide consortium, and 1.5 ~ 2 times scale of the facilities required depending on the processes, with a human--resource scale of 200-250 persons (to be further studied).</p>	
9	<p>Project implementation plan: -- The ILC project implementation has been updated and submitted to the Linear Collider Board (LCB) and reviewed by the Project Advisory Committee (PAC).</p>	
10	<p>Further key preparatory works required: <u>Civil engineering:</u> -- geological survey, environmental impact study, drawings and engineering documentation to prepare for the construction <u>SRF cavity and cryomodule technology:</u> -- Cost--effective cavity production industrialisation including superconducting material, tuners and couplers with plug--compatible design, reflecting E-XFEL & LCLS experiences. -- Continuous efforts to improve cavity gradient performance and to mitigate the gradient degradation after the cryomodule assembly. <u>RF power technology :</u> -- Industrial production of Marx Generators as both a cost--effective and reliable power source. <u>Nano--beam technology:</u> -- The effort at the KEK--ATF to be continued to achieve the technical goal in both the beam size and the stability at the final--focus point, and to extend the performance to provide sufficient stability margin. <u>Positron production Technology:</u> -- A very reliable technology to be demonstrated, based on conventional technology as a backup for the more difficult undulator--based source of polarized positrons. The BDS tunnel design to enable accommodate both options. <u>Integrations and tests infrastructure:</u> -- Hub--laboratory (consortium) in each region with integration and test infrastructure to be prepared specially for the SRF cavity integration and test prior to delivery to the ILC. The hub--laboratory functioning capability and responsibility to be well understood and established</p>	(CR under discussion)

	Project Implementation Plan: -- Preparation for the global cooperation and for an International laboratory for the ILC realization is inevitably required, including the governance for the preparation, construction, and operation.	
--	---	--

Table A2. Summary of active and expected Change Requests and the management (as of July ,2015)

	Title	Contents	Proposed	Evaluated	Decision
CR-001	Add return dogleg to target by-pass	Add additional lattice to bring BDS beamline on axis with main linac, to accommodate future >1 TeV beam energies.		Too early	No
CR-002	Adopt equal L* for both detectors	Find solution for single L* value for BDS and both detectors		Good	Yes
CR-003	Detector hall with vertical shaft access	Consolidated solution for IR hall / layout which supports surface construction of the detectors.		Good	Yes
CR-004	Extension of the electron and positron Main Linac tunnels by ~ 1.5km	Lengthen Main Linac tunnels by about 1.5km, to (i) fulfill the Global Timing constraint and (ii) add margin for total beam energy as risk mitigation to ensure 500GeV CME.		Good	Yes
CR-005	Update top-level parameters	Correct errors in reported luminosity for 500 GeV baseline and 1 TeV (b) parameters.		Good	Yes
CR-006	Add BPM downstream of QD0	Add a BPMs immediately downstream of the QD0s to facilitate beam capture and construction of a "virtual IP BPM".		Good	Yes
CR-007	Adoption of the Asian design as sole baseline	Only the Asian version of the TDR designs will be the basis for further development; the baseline HLRF distribution scheme will be DKS, the CFS planning will be based on the mountainous topography design.		Good	Yes
CR-008	Formal release TDR-2015a lattice	Complete set of matched lattices reflecting TDR design		Good	Yes
CR-TBD	ML central wall thickness reduction	Optimization of wall thickness with decision of no-human access during beam acceleration.	To be proposed		
CR-TBD	Cryogenics layout	Major components to be placed on surface	To be proposed		
CR-TBD	BDS tunnel layout	Enabling e-driven e+ source to be accommodated in parallel to the undulator driven e+ source	Being discussed		
CR-TBD	SRF cavity integration	Re-baseline design for SRF cavity integration including input-couplers and tuners	Being discussed		

Appendix 2:

Figures for major technical design update and change management in progress.

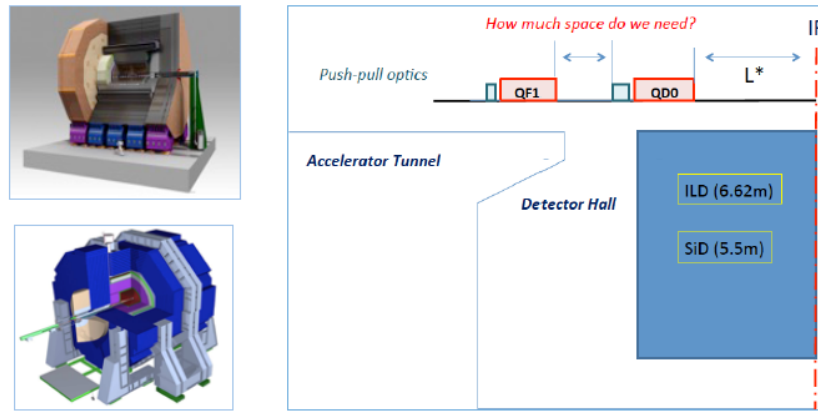

Fig. A2---1. Illustration for CR 2: Equalization of L^* for both ILC and SID detectors.

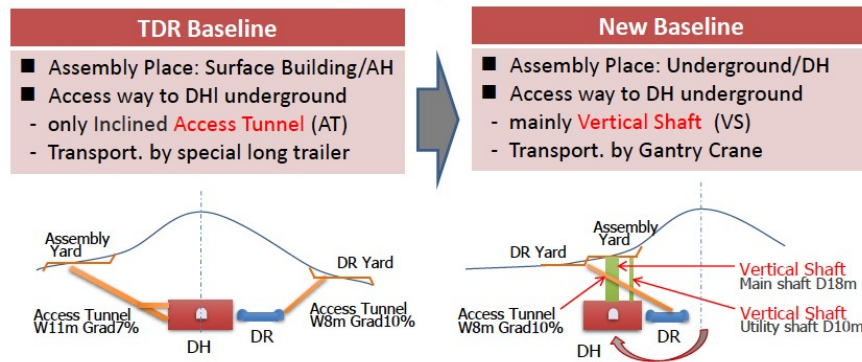

Fig. A2-2. Illustration for CR 3: Vertical shaft access to the detector hall at IP.

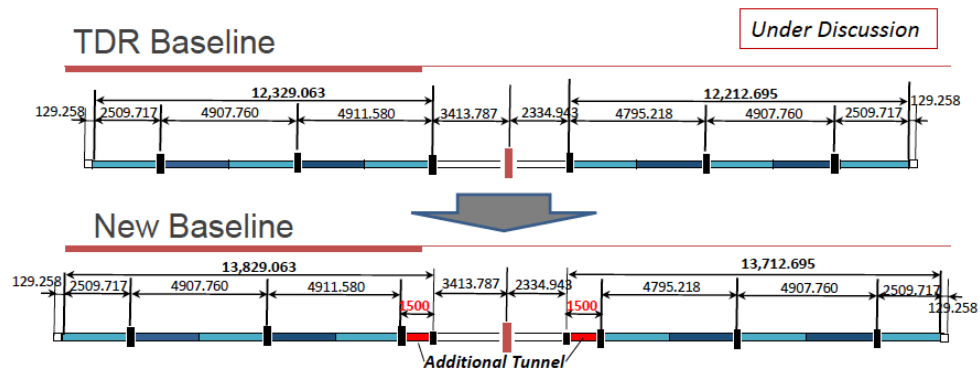
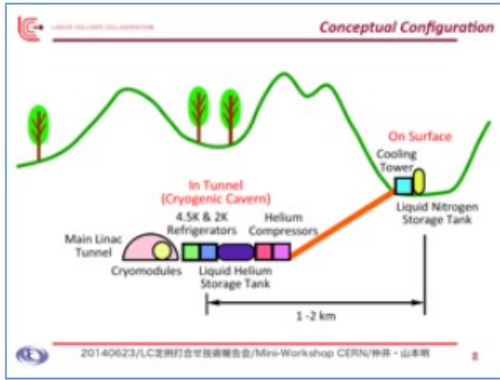

Fig. A2-3. Illustration for CR 4: Adding ML tunnel lengths for both e+e- timing and more reliable reaching 500 GeV

ILC-TDR Baseline



New Baseline to be proposed to CMB

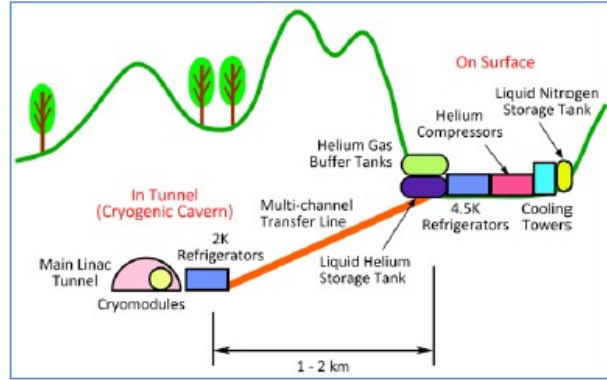

Fig. A2---4. Illustration for Cryogenic layout change, CR in preparation

	Baseline SW3.5m	Option-1 SW2.5m	Option-2 SW1.5m
Cross Section			
Cross Section	W11m x H5.5m 62.7 m ²	W10m x H5.5m 57.2 m ²	W9m x H5.5m 51.9 m ²

Fig. A2---5. Illustration for ML tunnel central wall thickness, CR in preparation.

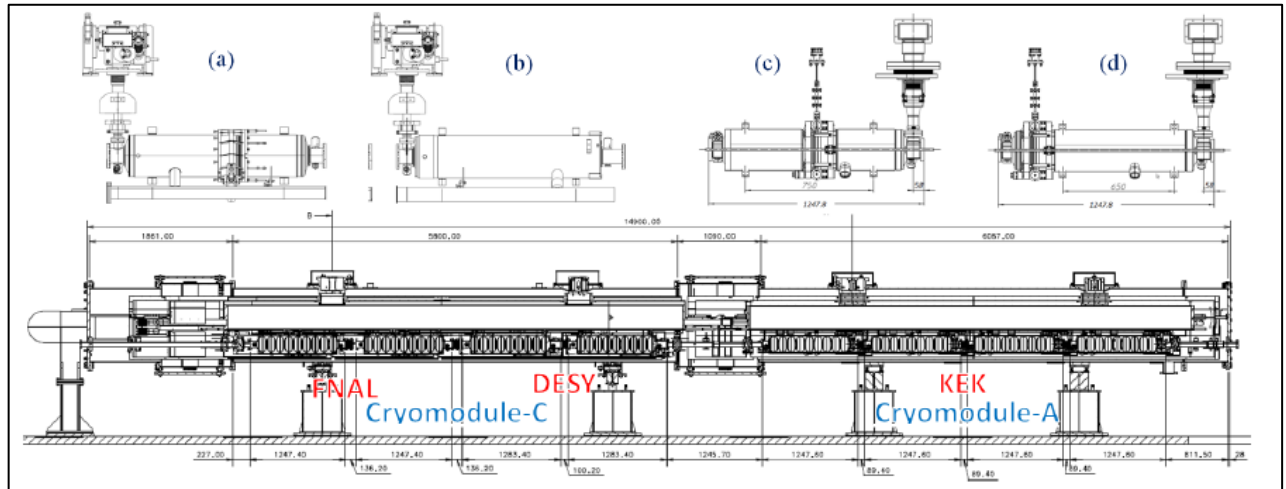

Fig. A2---6. Cavity and CM configuration at S1---Global Program.

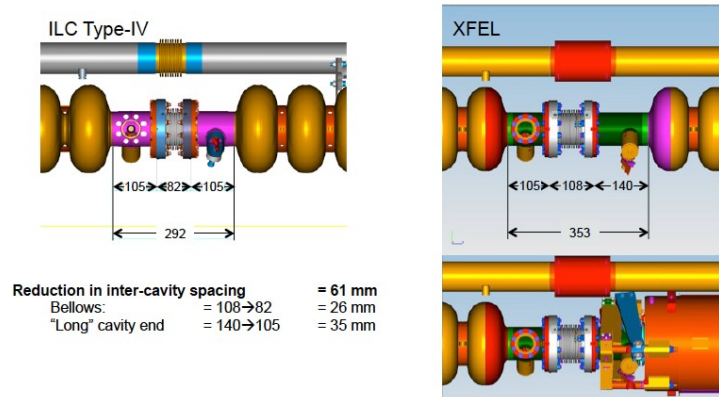

Fig. A2---7. Longitudinal interconnect constraint for the ILC and EFXEL cavity string.

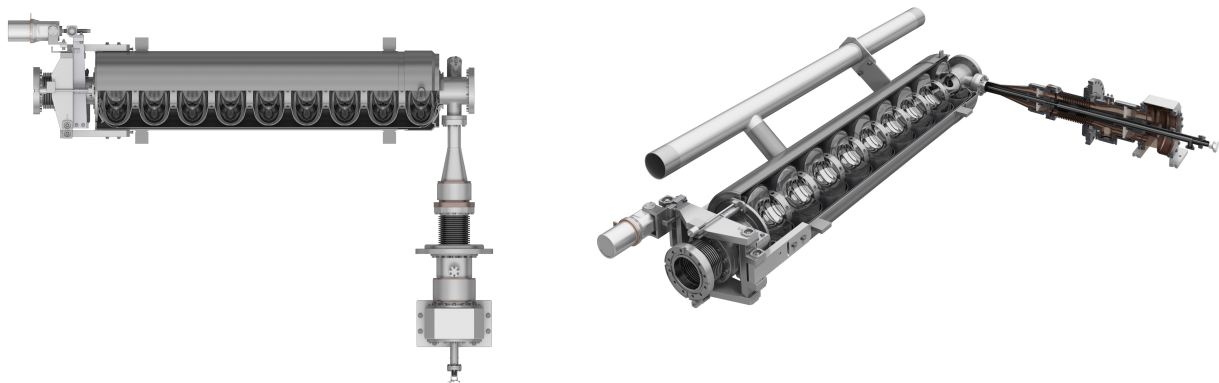

Fig. A2 –8. A cavity configuration being studied, for a new baseline.