

PRECISION MEASUREMENTS of the τ LIFETIME

Richard Kass

The Ohio State University

INTRODUCTION

One of the cornerstones of the standard model of electroweak interactions is the universality of the charged coupling constant. For the case of the τ lepton e , μ , τ universality allows us to calculate the lifetime of the τ in terms of the μ mass and lifetime, τ mass and the branching ratio of τ into electrons or muons. Thus a measurement of the τ lifetime is of primary importance as it either affirms the standard model or provides evidence beyond the standard model. In this note we speculate on the opportunities for measuring the τ lifetime at various laboratories over the next few years.

REVIEW OF EXPERIMENTAL TECHNIQUE

Conceptually the measurement of the τ lifetime is simple. The lifetime determination involves: a) collecting a sample of τ events with known 4 momenta (p_τ), b) measuring the decay length of each τ in the sample, c) calculating the average decay length (\bar{L}) of the τ sample, and d) calculating the τ average lifetime from:

$$\tau_\tau = m_\tau \bar{L} / p_\tau c \quad (1)$$

with c the speed of light.

In fact the program outlined above is unrealistically simple in many regards. Due to lepton number conservation all τ decays have a neutrino in the final state. Thus determining the τ momentum by measuring its decay products is impossible. Obtaining a sample of τ 's with known momenta is possible only at an e^+e^- storage ring. There one assumes that the energy of the τ is equal to the beam energy. Even this assumption is complicated due to the effects of initial state radiation.

To date all τ lifetime measurements¹⁾ have been performed by experiments where neither the production nor the decay point of the τ could be directly measured. Due to the relatively short decay length of the τ , typically less than 1 mm, both the production and decay point of the τ are inside the vacuum of the beam pipe. Thus any information on the decay path length must be inferred from the decay products of the τ . There are several factors that determine the accuracy to which the τ decay path length can be measured. Two of the most important of these factors are the amount of multiple scattering that occurs before the trajectories of the decay products are measured and the distance between the τ decay point and the charged particle tracking devices. Another important parameter is the size of the electron and positron beam. Due to the finite extent of the beams the τ 's are not produced in a pointlike region, but in an ellipsoidal region corresponding to the overlap of the two beams. As the actual production point of the τ cannot be seen on an event by event basis, the average beam position must be used in the lifetime analysis.

There are two common techniques, the vertex method and the impact parameter method, used to relate the measured trajectories of the τ decay products to the τ lifetime. As its name implies, the vertex method finds a common point of origin (vertex) for two or more of the τ decay products. By using the average beam position and the measured decay vertex the flight path of the τ can be calculated. In Fig.1 the average τ flight path as a function of τ energy (beam energy for an e^+e^- collider) is displayed.

In Fig. 2 we define the variables relevant to the vertex method. The best estimate for the intersection of two or more tracks in the xy or $\tau\phi$ plane is given by equation 2:

$$L_{xy} = \frac{x\sigma_{yy}t_x + y\sigma_{xx}t_y - \sigma_{xy}(xt_y - yt_x)}{\sigma_{yy}t_x^2 + \sigma_{xx}t_y^2 - 2\sigma_{xy}t_yt_x} \quad (2)$$

Here x and y are the coordinates of the vertex, σ_{xx} , σ_{yy} , and σ_{xy} are the elements of the error matrix associated with the vertex, and t_x , t_y are the direction cosines of the τ . The direction cosines are obtained from the momentum vectors of the τ decay products. Most experiments rely on a complicated fitting

procedure for the determination of x , y , and the associated error matrix elements. At this stage of the analysis the z coordinate information is often ignored as the spatial resolution in z is typically an order of magnitude worse than the $\tau\phi$ resolution. Once the estimate for L_{xy} is found, the three dimensional flight path is calculated from:

$$L = L_{xy} / \sin\theta \quad (3)$$

In the above equation $\sin\theta$, like the direction cosines, is calculated using information from the measured momenta of the τ decay products. The distribution of L for two different experiments²⁾ is shown in Fig. 3. The data from both experiments are clearly offset from zero, indicating a non-zero lifetime. The negative values of L in the figure are the combined result of detector resolution and uncertainty due to the finite width of the beams.

The impact parameter method is illustrated in Fig. 4 for both the ideal and realistic case. In this method the distance of closest approach (d_i) of a decay product to the τ production point is measured. The distance of closest approach (impact parameter) is related to the τ flight path (L) by:

$$L = d_i / \sin\psi_i \sin\theta \quad (4)$$

with ψ_i defined in Fig. 4 and $\sin\theta$ defined as for the vertex method. The impact parameter vs τ energy for electrons from $\tau \rightarrow e\nu\bar{\nu}$ is shown in Fig. 5. Note that for τ energies above ≈ 10 GeV the impact parameter is practically constant. We can understand the high energy behavior of the impact parameter by recalling that while L is increasing by the Lorentz factor γ , the angle ψ is decreasing by the same factor. Thus d_i will remain approximately constant.

Several experiments have measured the τ lifetime using both the impact parameter and the vertex method³⁾. While the methods are not completely independent, they stress different aspects of track and vertex reconstruction. The impact parameter method is free from the complexities introduced by vertex fitting and gives several measurements per event. However, converting the measured impact parameter to a lifetime can only be done with the aid of a Monte Carlo. Consistent results from both methods serve as a powerful check on the systematic errors associated with the lifetime measurement.

To date the τ lifetime has been measured at beam energies ranging from 5 to 20 GeV with measurements at energies up to 45 GeV expected shortly. In deciding what is the optimum energy at which to measure the τ lifetime, many factors must be taken into account. Low energy measurements (e.g. 5 GeV) are complicated by the relatively short decay length of the τ , multiple scattering of the τ decay products, hadronic backgrounds, and the finite dimensions of the beams. While some of the above problems diminish in importance as the τ energy increases, vertex location remains a problem even at high energies. This is illustrated in Fig. 6 where a τ as displayed by the CLEO detector ($E_{beam}=5$ GeV) is shown along side and on the same scale as a τ from the AMY detector ($E_{beam}=30$ GeV). Due to the Lorentz boost at 30 GeV the decay products from the τ do not separate until they are well within AMY's main drift chamber. This is in contrast to the CLEO case where the secondaries are well separated before entering any of the tracking chambers. Thus while the τ decay path length increases like beam energy, so does the measurement uncertainty in this quantity. Another disadvantage of high energy measurements is the difficulty in obtaining a large sample of τ events due to the $1/s$ dependence of the $e^+e^- \rightarrow \tau^+\tau^-$ continuum cross section. This problem is illustrated in Table 1 where the τ sample for several PEP ($\sqrt{s}=29$ GeV) experiments is given along with the CLEO ($\sqrt{s}=10$ GeV) data sample.

REVIEW OF PRESENT EXPERIMENTAL RESULTS

Figure 7 shows the seven latest measurements of the τ lifetime. In this figure the first error represents the statistical uncertainty while the second error represents the systematic uncertainty. The standard model prediction⁴⁾ for the τ lifetime, $2.80 \pm 0.04 \times 10^{-13}$ sec, is also shown in Fig. 7. Note that the standard model prediction is smaller than any individual measurement.

TABLE 1. A summary of the characteristics of several detectors. The efficiency, ϵ_{1vs3} , is defined to be the number of 1 vs 3 τ events used in the lifetime analysis (vertex method) divided by the number of 1 vs 3 τ events detected.

Detector	Events Used 1 vs 3	ϵ_{1vs3}	Radius 1 st layer (cm)	Statistical Precision %	$\delta c\tau/c\tau$
HRS	1311	0.46	9	5	1.8
MAC	532	0.56	5	7.8	1.8
MARK II	807	0.45	10	5.5	1.6
CLEO	7150	0.8	8	4.1	3.4

As shown in Fig. 7, each experiment measures the τ lifetime to better than 10%, the best measurement being $\approx 6\%$. Unfortunately, it is not clear how one should average these measurements as the statistical spread of the measurements is smaller than one would anticipate if the measurements were uncorrelated. There are many possible sources of correlated errors in e^+e^- experiments. For example, most of these experiments use the same Berends and Kleiss⁵⁾ based Monte Carlo to calculate radiative corrections for acceptances and cross sections. Thus the significance of the discrepancy between the standard model prediction and the measurements in Fig. 7 will remain clouded until either a correct lifetime averaging procedure can be arrived at, or more precise measurements of the τ lifetime can be made.

The time evolution of τ lifetime measurements is shown in Fig. 8. In this figure all published values of the τ lifetime are plotted as a function of time. Unlike the case of the muon lifetime (Fig. 9) there are no sudden jumps or falls in the data set. Whether this lack of structure in the τ lifetime measurements reflects the skill of the experimenters making these measurements or reveals a trend which no experiment dares to break is for the reader to determine.

STATISTICS AND THE τ LIFETIME

The precision to which the τ lifetime can be measured depends on both the sample size and the systematic uncertainties inherent in the particular experiment. Experiment dependent systematic errors will be discussed in detail in a later section, here we concentrate on the uncertainty due to the sample size. The statistical precision (P) of a lifetime measurement is related to the sample size (n) by:

$$P = \frac{1}{\sqrt{n}} (1 + (\delta c\tau/c\tau)^2) \quad (5)$$

In Eq. 5 $\delta c\tau/c\tau$ represents the relative error in a single decay length measurement. In Fig. 10 the statistical precision of a τ lifetime measurement vs τ sample size is shown for several values of $\delta c\tau/c\tau$. Table 1 gives the value of $\delta c\tau/c\tau$ for several experiments⁶⁾. To date the best experiments have $\delta c\tau/c\tau \approx 1.5 - 2$, the shaded region in Fig. 10. Future experiments at LEP and TRISTAN are also expected to fall into this $\delta c\tau/c\tau$ region. Thus unless there is a significant advance in charged particle tracking systems τ event samples in excess of $\approx 20,000$ will be necessary for lifetime measurements of $\approx 1\%$.

PROSPECTS FOR FUTURE τ LIFETIME MEASUREMENTS

In the next 1-2 years a new round of τ lifetime measurements is expected from both existing accelerators and the new Z factories. In this section we speculate on the accuracy of these lifetime measurements starting with the Z factories.

• LEP

In the next two years LEP is expected to generate $\approx 10^6$ Z 's. The Standard Model prediction for $Z \rightarrow \tau^+\tau^-$ is $\approx 3\%$. Thus τ event samples of $\approx 3 \times 10^4$ can be expected from LEP in the near future. Unfortunately not all of these τ 's can be used in the lifetime measurement. We can estimate the number

of useable τ events from the following data: a) the branching fraction for $\tau \rightarrow 1$ vs $3 \approx 25\%$, b) typical detector acceptances and efficiencies for 1 vs 3 events $\approx 2/3$ and c) typical track quality and vertex reconstruction efficiencies ≈ 0.5 (Table 1). Thus the number of useable Z 's is estimated from the product of a, b, and c and the number of τ pairs produced. Using the above numbers we estimate 2500 useable events.

The statistical precision of a lifetime measurement using 2500 events depends on the value of $\delta c\tau/c\tau$ as illustrated in Fig. 10. Without a detailed Monte Carlo calculation it is hard to estimate $\delta c\tau/c\tau$ for the LEP detectors. One would not expect small values of $\delta c\tau/c\tau$ from these detectors as charged particle tracking for 3 prong τ events will be difficult due to the extreme jettiness ($\beta\gamma \approx 28$) of these events and the large (≈ 9 cm) radius of the beam pipe. A conservative estimate is to assume that the LEP detectors will do as well as the PEP detectors, i.e. $\delta c\tau/c\tau \approx 1.5-2$ (Table 1). Using this information and Fig. 10 we can expect the statistical precision of the LEP experiments to be 3-4%.

As with the case of the statistical precision, the systematic uncertainty can only be accurately determined using a detailed Monte Carlo. It is clear however that several sources of systematic error that are important at lower energies will be small at LEP. Two such examples are hadronic contamination of the τ sample and beam position jitter. The hadron contamination is expected to be small as the charged multiplicity of hadronic decays of the Z is much greater than the charged multiplicity of τ decays. Effects due to beam position jitter are minimized by the long (≈ 2.5 mm) average flight path of the τ . While it is difficult to give a number for the systematic error, it seems safe to expect the systematic error to be smaller than the statistical error in the lifetime measurement.

• SLC

The SLC is not expected to yield as large a τ sample as LEP. However, the small radius of the beam pipe (≈ 1 cm) at SLC has the potential for making up for this lack of a large τ sample. For example, if a tracking detector could be located 1 cm from the interaction point then $\approx 1.5\%$ of the τ 's would decay in this device. This would be the first experiment where the decay point of the τ could be measured directly. Thus even if the decay point could only be localized to 1 mm, $\delta c\tau/c\tau \approx 0.1$, an order of magnitude smaller than any other experiment. With this device it would be possible to obtain a τ lifetime measurement $\leq 10\%$ with only a few hundred of these visible decays.

• TRISTAN

TRISTAN is the highest energy e^+e^- collider without a resonance to enhance the τ cross section. At $\sqrt{s} = 60$ GeV the τ pair production cross section is only ≈ 30 pb. Thus to collect a sample of τ 's equivalent to the LEP sample, an integrated luminosity of ≈ 1 fb $^{-1}$ will be necessary. A data sample this large is out of the reach of TRISTAN unless its luminosity is upgraded by at least an order of magnitude.

• PEP

PEP is an intermediate energy e^+e^- collider and as such has the advantage of both a relatively long τ flight path and a moderately large τ pair cross section. At the present time there is only one high energy physics experiment at PEP, the TPC. The charged particle tracking capabilities of the TPC have recently been upgraded with the addition of a 14 layer tube style vertex detector and small radius low mass beam pipe. Detailed Monte Carlo studies indicate⁷⁾ that a τ lifetime measurement of 3% (combined statistical and systematic errors) is possible with the data accumulated from a 1 fb $^{-1}$ run. While PEP is capable of obtaining such a data set in the next 1-2 years, there are presently no plans to run PEP during this time period.

• CESR

CESR is a low energy ($\sqrt{s} = 10$ GeV) high luminosity e^+e^- collider. Prior to the shutdown for the CLEO II upgrade, instantaneous luminosities of 10^{32} /cm 2 -sec and daily integrated luminosities of 5 pb $^{-1}$ were obtained. The luminosity of CESR is expected to increase to 25 pb $^{-1}$ /day in the next year as the result of an ambitious accelerator improvement program. The τ pair cross section in this energy range is ≈ 1 nb. Thus a data sample of 10^6 τ 's per year is obtainable assuming, conservatively, that CESR runs

200 days/year at $5 \text{ pb}^{-1}/\text{day}$.

While the CLEO II detector was designed with B meson physics in mind, it is also an excellent detector for τ studies. CLEO II is designed to be a high resolution spectrometer for both charged and neutral particles. The heart of the detector is an 8000 element CsI electromagnetic calorimeter which covers 95% of the solid angle. The expected energy resolution of the calorimeter is shown in Fig. 11, along with several other detectors. The charged particle tracking has also been improved with the addition of a 3.5 cm Beryllium beam pipe and a new 6 layer tube style vertex detector, the PTL⁵). As can be seen in Fig. 12, there are now 16 high resolution ($\approx 90\mu$) measurements in the $\tau\phi$ plane before the main CLEO II drift chamber. These 16 layers alone give a single particle impact parameter measurement of 100μ at 1 GeV.

An estimate of how well CLEO II can measure the τ lifetime can be made using CLEO's 1987 measurement (Ref. 2) as a guide. The 1987 sample contained 7200 useful τ decays obtained from 144 pb^{-1} of data. Assuming that CLEO II has the same τ efficiencies as CLEO, a conservative assumption, a 1 fb^{-1} run will yield 5×10^4 useful τ events. The vertex resolution of CLEO II is about a factor of 2 better than that of CLEO. This improvement comes about because of the smaller radius of the new beam pipe (3.5 cm vs 8 cm) and the additional layers of charged particle tracking (16 vs 10). Assuming that the spread in the beam dimensions remains the same as that for CLEO, we expect $\delta c\tau/c\tau \approx 1.8$. Using this value for $\delta c\tau/c\tau$ and the above estimate for the number of τ events we estimate a statistical uncertainty of 0.8% for the τ lifetime measurement.

The systematic error in the lifetime measurement can be estimated using the same procedure as above. The dominant source of systematic error in the 1987 measurement was due to the hadronic contamination in the τ sample. The 1987 sample suffered from a $14 \pm 4\%$ contamination, mostly from continuum charm production. Much of this background could be eliminated with a good measurement of the total energy deposited in the detector. The CLEO II detector should have better discrimination against non- τ events as the calorimeter covers twice the solid angle and has 10x the energy resolution as the original CLEO detector. Monte Carlo studies of CLEO II indicate that the background (including the two photon process) in the τ sample should be $\approx 5\%$, leading to a 0.9% contribution to the systematic error.

Two other sources of systematic error are the uncertainty in the lifetime of the background events and biases in the vertex reconstruction algorithms. Assuming that there is no improvement over CLEO in understanding the lifetime of the background, the contribution to the systematic error from this source will be 0.7%. The uncertainty from vertex reconstruction is expected to be much smaller for CLEO II compared with CLEO due to the improvements in the charged particle tracking system. A conservative estimate for this contribution to the systematic error is 1%, half the value of the 1987 analysis. Combining the above estimates for the systematic error in quadrature leads to a total systematic error of $\leq 1.5\%$. Thus it appears that the CLEO II experiment is capable of measuring the τ lifetime to $\leq 2\%$.

CONCLUSION

The next few years promise to be rich in new measurements of the τ lifetime. Single experiment measurements of the τ lifetime in the few percent range are expected from several laboratories. These measurements along with equally precise measurements of the τ leptonic branching fraction could provide indications of physics beyond the standard model.

ACKNOWLEDGEMENTS

The author would like to thank all those involved with the organization of the workshop. I would also like to thank Garry Trahern for help with preparing this document and Barry Barish for an important discussion concerning statistics. This work was supported by D.O.E. contract No. DE-AC02-76ER01545.

REFERENCES AND FOOTNOTES

- 1) A complete set of lifetime measurements can be found in the following references: Particle Data Group, M. Aguilar-Benitez et al. Phys. Lett., 204B, (1988); C. Kleinwort, et al., Z. Phys. C - Particles and Fields, 42, 7 (1989); W. Braunschweig, et al., Z. Phys. C - Particles and Fields, 39, 331 (1988).
- 2) The data are from the CLEO collaboration, S.E. Csorna et al., Phys. Rev. D35, 2747 (1987); and the

- HRS collaboration S. Abachi et al., Phys. Rev. Lett. 56,1039 (1986).
- 3) For example, the analysis of the CLEO collaboration, reference 2.
 - 4) The standard model prediction for the τ lifetime is calculated using the Particle Data Group's (see Ref. 1) values for m_τ (1784 ± 3 MeV) and $BR(\tau \rightarrow e\nu\bar{\nu})$ (0.175 ± 0.004).
 - 5) F. A. Berends, R. Kleiss, Nucl. Phys. B177, 237 (1981).
 - 6) CLEO collaboration, S.E. Csorna et al., Phys. Rev. D35, 2747 (1987); HRS collaboration S. Abachi et al., Phys. Rev. Lett. 56,1039 (1986); MAC collaboration H. R. Band et al., Phys. Rev. Lett. 59,415 (1987); MARK II collaboration D. Amidei et al., Phys. Rev D37,1750 (1988).
 - 7) Private communication from Elliott Bloom and Geordie Zapalac.
 - 8) PTL stands for Precision Tracking Layers.

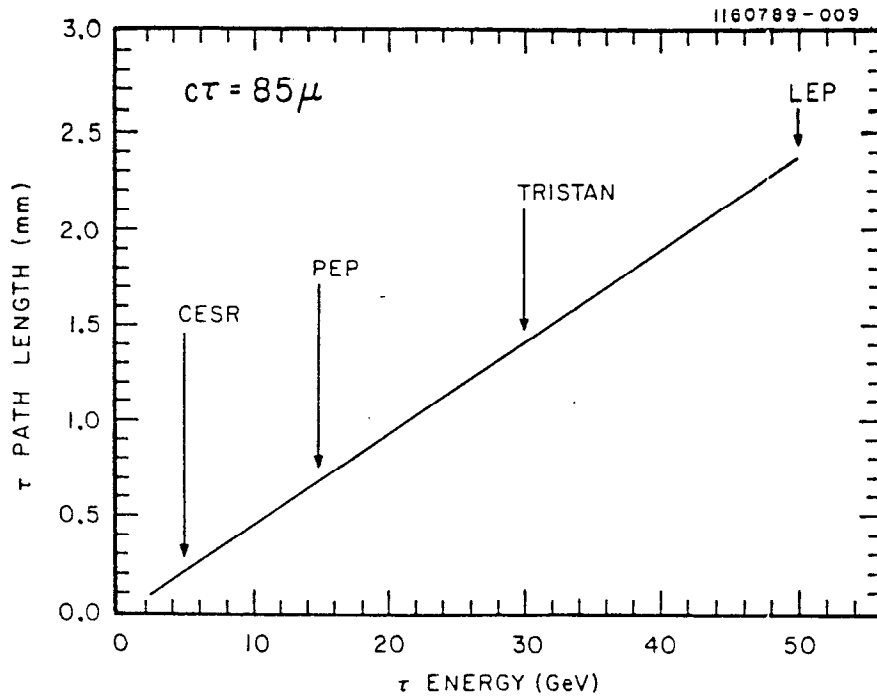

Fig 1. The average τ flight path as a function of τ energy.

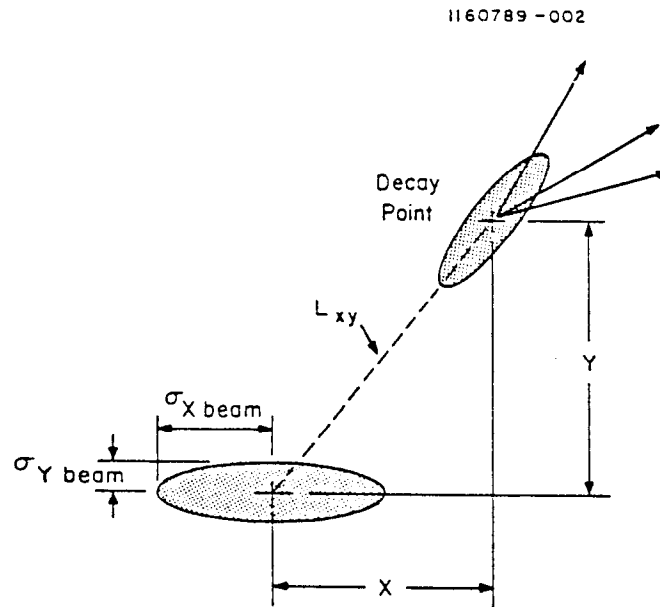

Fig. 2. Definition of the variables used in the vertex method.

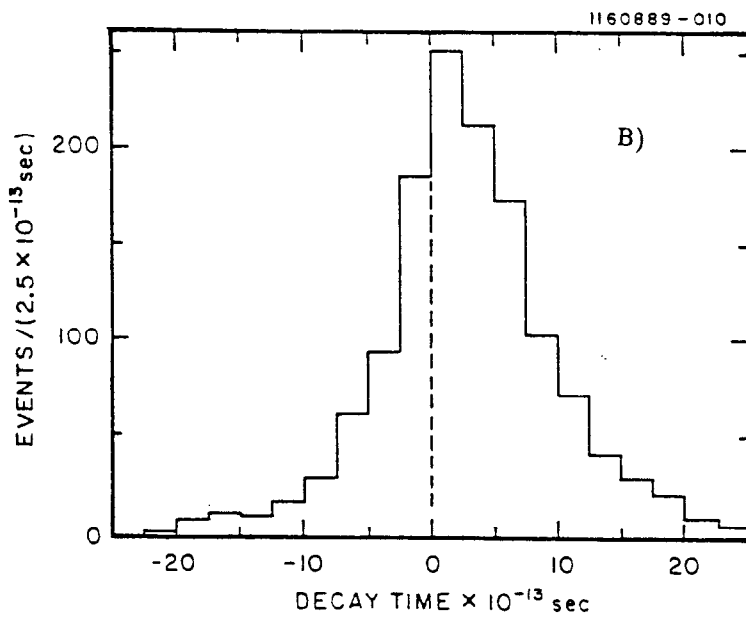
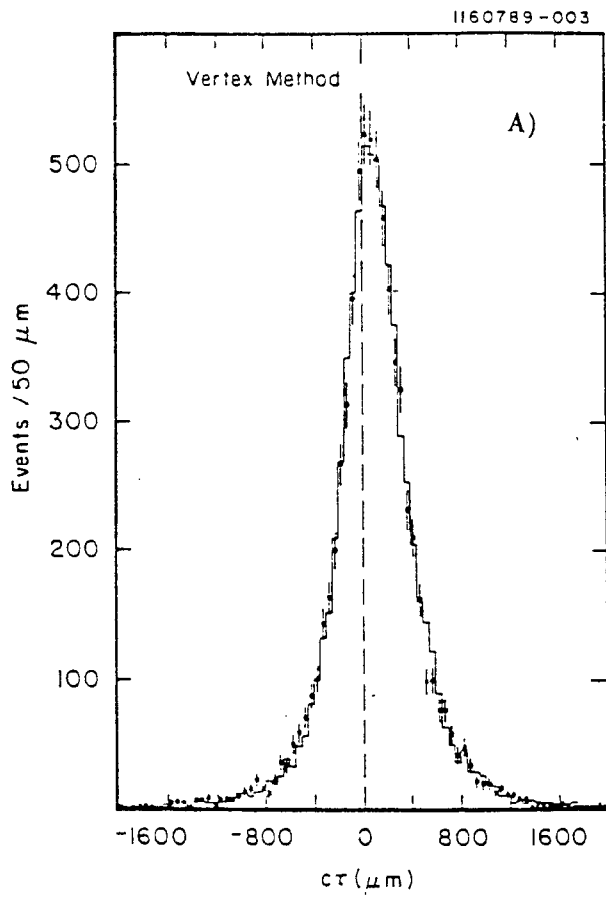

Fig. 3. The τ candidate decay distribution from a) the CLEO experiment and b) the HRS experiment. In both cases the dashed line represents a zero lifetime.

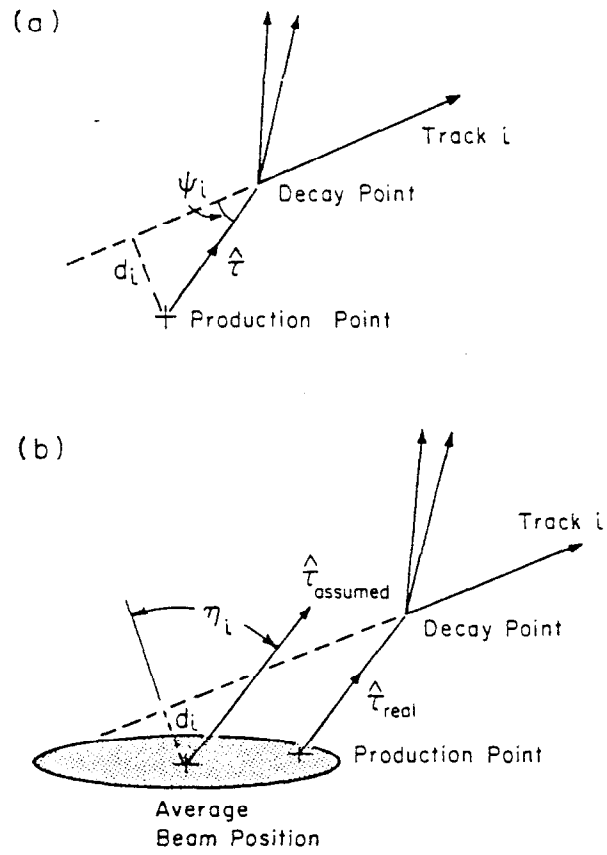

Fig. 4. The variables used in the impact parameter method for a) the ideal case and b) the realistic case.

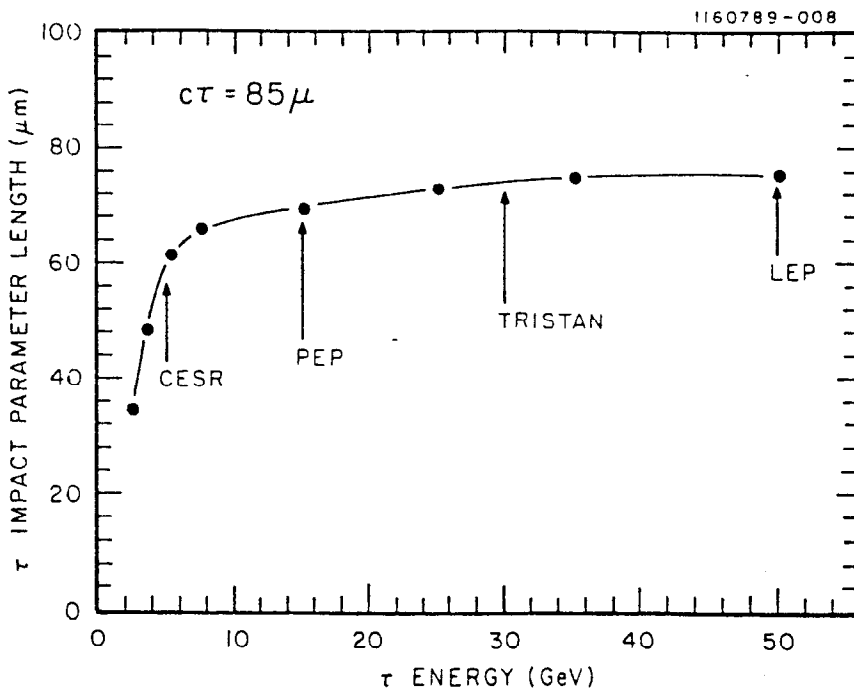

Fig. 5. The average impact parameter of electrons from leptonic τ decay as a function of τ energy.

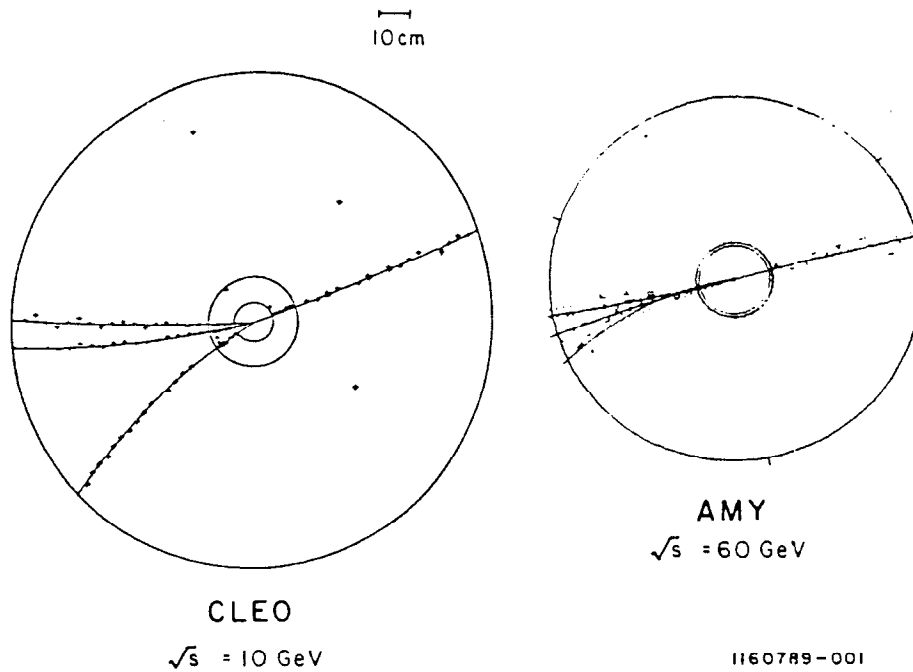

Fig. 6. Comparison of a 1 vs 3 prong τ decay from the CLEO experiment with a similar event from the AMY experiment. Note that the scale is the same for both events.

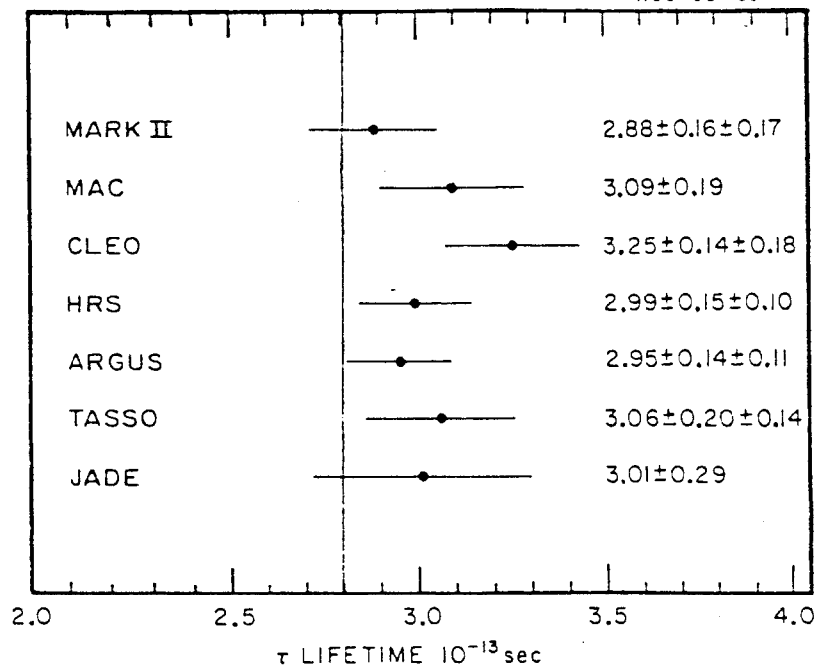

Fig. 7. The seven latest measurements of the τ lifetime. The solid line is the standard model prediction of this quantity.

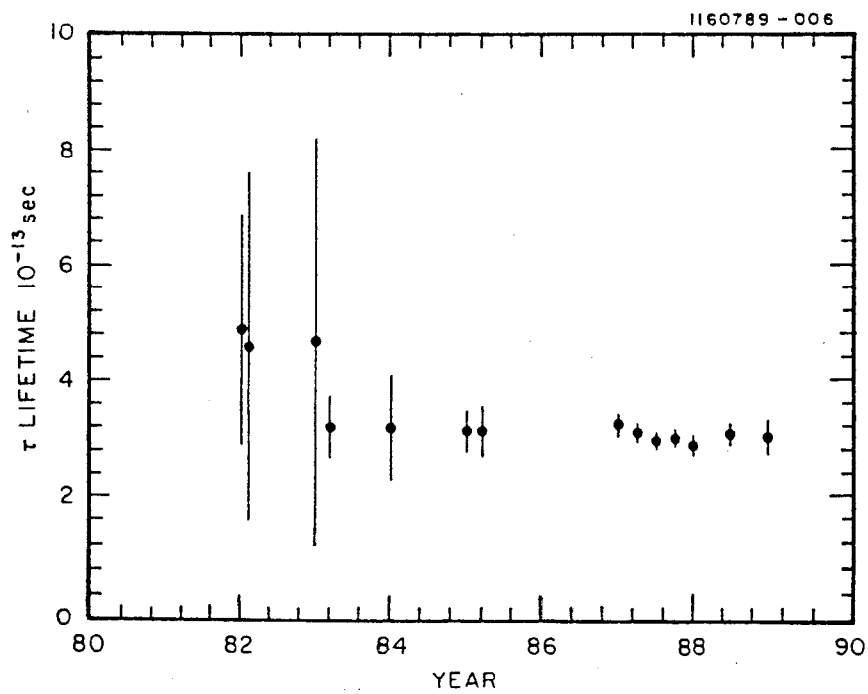

Fig. 8. The time evolution of the τ lifetime.

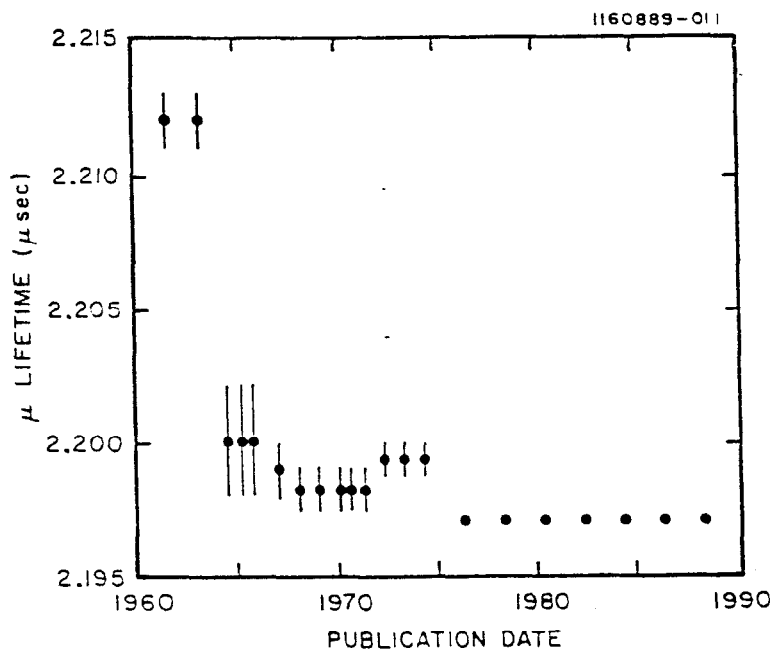

Fig. 9. The time evolution of the muon lifetime.

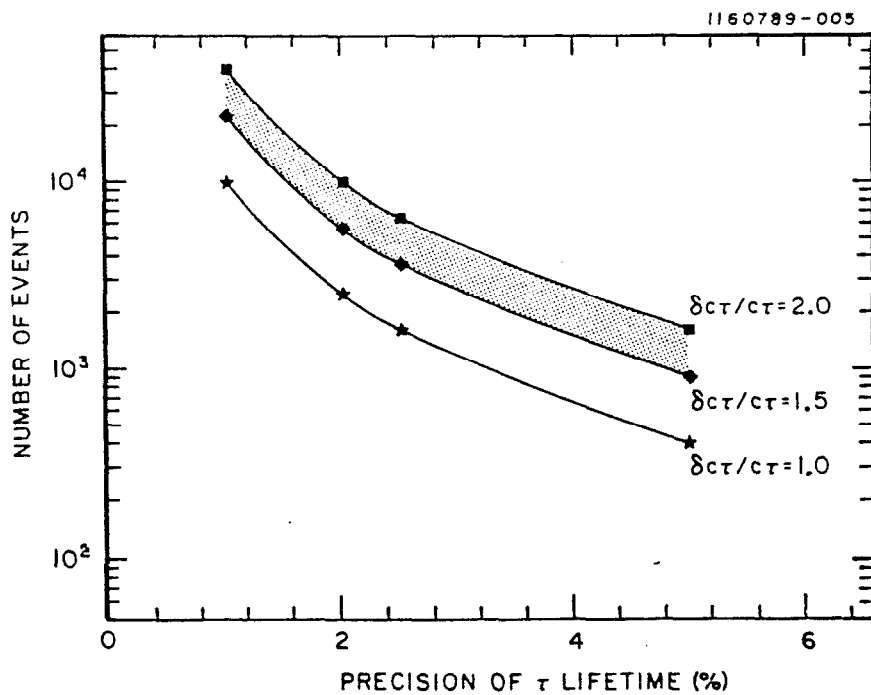

Fig. 10. The statistical precision of the τ lifetime as a function of the number of events and the tracking quality of the detector. Here $\delta c\tau/c\tau$ is the relative error in a single decay length measurement.

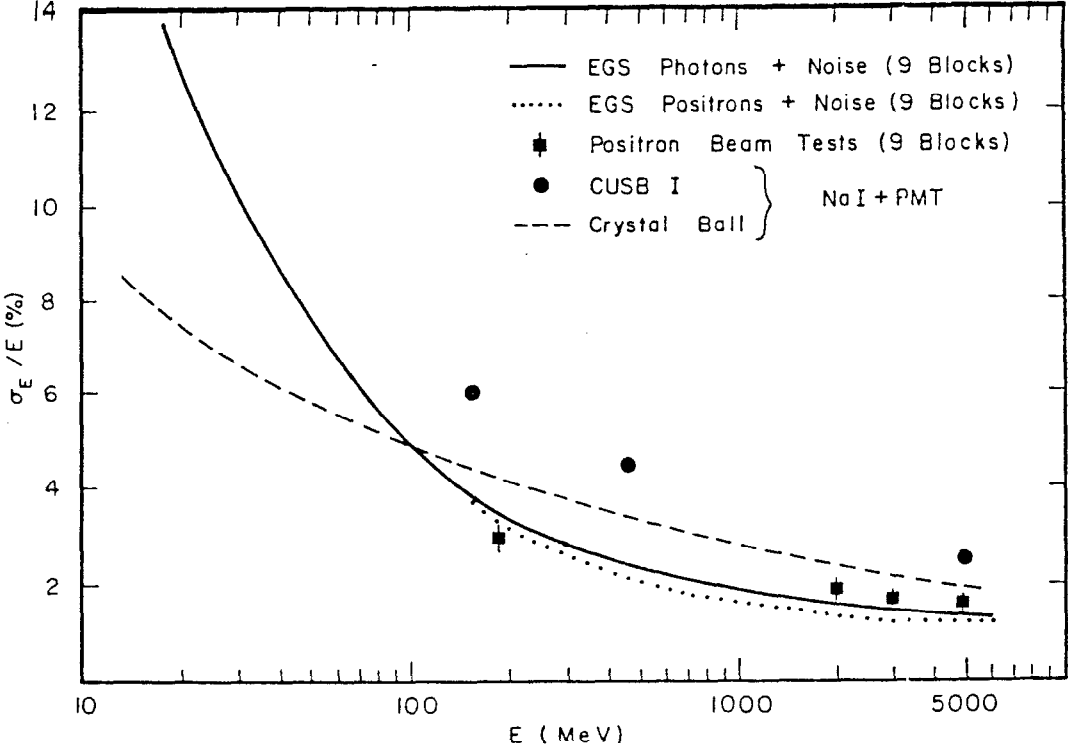

Fig. 11. The expected energy resolution of the CLEO II calorimeter as a function of positron or photon energy.

CLEO VERTEX DETECTOR

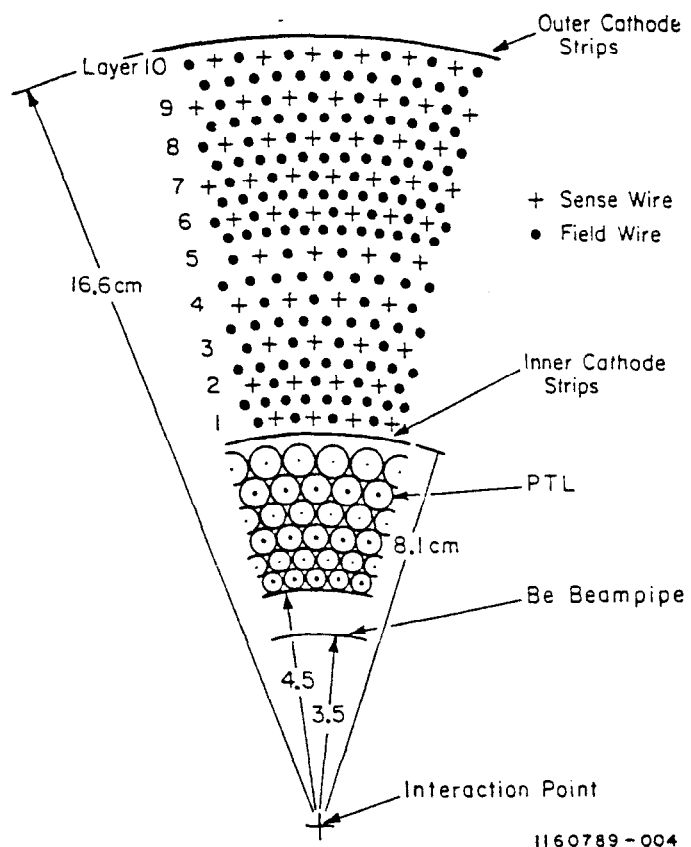

Fig. 12. The CLEO II interaction region including the beam pipe, PTL, and Vertex detector.