

## The Cryogenic System for the SLAC E158 Experiment

J.G. Weisend II<sup>a</sup>, R. Boyce<sup>a</sup>, W. Burgess<sup>a</sup>, A. Candia<sup>a</sup>, R. Carr<sup>b</sup>,  
J. Gao<sup>b</sup>, K. Gustafsson<sup>b</sup>, C. Jones<sup>b</sup>, W. Kaminskas<sup>a</sup>, G. Oxoby<sup>a</sup>,  
R. McKeown<sup>b</sup>, H. Quack<sup>c</sup>, A. Scott<sup>b</sup> and T. Weber<sup>a</sup>

<sup>a</sup>Stanford Linear Accelerator Center, Stanford, CA., 94309 USA

<sup>b</sup>California Institute of Technology, Pasadena, CA., 91125, USA

<sup>c</sup>Technische Universität Dresden, Dresden, Germany

Presented at 2001 Cryogenic Engineering Conference/International Cryogenic  
Materials Conference, 7/17/2001—7/20/2001, Madison, WI, USA

---

*Stanford Linear Accelerator Center, Stanford University, Stanford, CA 94309*

Work supported by Department of Energy contract DE-AC03-76SF00515.

## The Cryogenic System for the SLAC E158 Experiment

J.G. Weisend II<sup>a</sup>, R. Boyce<sup>a</sup>, W. Burgess<sup>a</sup>, A. Candia<sup>a</sup>, R. Carr<sup>b</sup>,  
J. Gao<sup>b</sup>, K. Gustafsson<sup>b</sup>, C. Jones<sup>b</sup>, W. Kaminskas<sup>a</sup>, G. Oxoby<sup>a</sup>,  
R. McKeown<sup>b</sup>, H. Quack<sup>c</sup>, A. Scott<sup>b</sup> and T. Weber<sup>a</sup>

<sup>a</sup> Stanford Linear Accelerator Center, Stanford, CA., 94309 USA

<sup>b</sup> California Institute of Technology, Pasadena, CA., 91125 USA

<sup>c</sup> Technische Universität Dresden, Dresden Germany

### ABSTRACT

E158 is a fixed target experiment at SLAC in which high energy (up to 48 GeV) polarized electrons are scattered off the unpolarized electrons in a 1.5 m long liquid hydrogen target. The total volume of liquid hydrogen in the system is 55 l. The beam can deposit as much as 700 W into the liquid hydrogen. Among the requirements for the system are: that density fluctuations in the liquid hydrogen be kept to a minimum, that the target can be moved out of the beam line while cold and replaced to within 2 mm and that the target survive lifetime radiation doses of up to  $1 \times 10^6$  GY. The cryogenic system for the experiment consists of the target itself, the cryostat containing the target, a refurbished CTI 4000 refrigerator providing more than 1 kW of cooling at 20 K and associated transfer lines and valve boxes. This paper discusses the requirements, design, construction, testing and operation of the cryogenic system. The unique features of the design associated with hydrogen safety and the high radiation field in which the target resides are also covered.

### INTRODUCTION

E158 is a high energy physics experiment [1] currently underway at the Stanford Linear Accelerator Center (SLAC). The goal of the experiment is to make high precision measurements of the Weak Mixing Angle in Moeller (electron – electron) scattering at an energy of 48 GeV. These measurements, which should set new records for precision, will allow the physicists to test the Standard Model of high energy physics and search for new phenomena. The experiment is conducted by scattering a beam of 48 GeV polarized electrons off a fixed target of unpolarized electrons. In order to maximize the electron – electron scattering rate while reducing unwanted interactions, the optimal target material is liquid hydrogen (LH<sub>2</sub>).

## **SYSTEM REQUIREMENTS**

### **Cooling**

The electron beam may deposit as much as 700 W into the liquid hydrogen. To allow for parasitic heat leaks and to provide an appropriate amount of margin, a cooling capacity of 1 kW at 14 K is required. To avoid influencing the physics measurement, the liquid hydrogen density should be essentially constant between the pulses of the beam. The spacing between the beam pulses is 8 ms. This effect can only be measured by examining the physics results of the experiment. Slower changes in liquid hydrogen density are less important but the temperature and pressure of the liquid hydrogen should be kept as constant as reasonably possible.

### **Alignment and Movement**

The center of the target must be aligned with respect to the center of the electron beam to within 2 mm. Additionally, the experiment requires that the target be moved out of the beam on a daily basis to allow for tests using room temperature solid targets or no targets at all. When the target is moved back into the beam, it must resume its alignment to within 2 mm.

### **Materials**

Over the multiyear lifetime of the experiment, the target and its cryostat that contains it may be exposed to up to  $1 \times 10^6$  Gy ( $1 \times 10^8$  Rad) of ionizing radiation. Materials used in the target and cryostat must be able to withstand these doses. Materials should also be chosen so that if they are activated their half lives are not excessively long. The physics of the experiment also require that there be no magnetic material within a 300 mm radius of the target center.

### **Safety**

The 55 liters of liquid hydrogen in the target have an explosive yield equivalent to 8 kg of TNT. Clearly, the system must be designed so that the possibility of an explosion is highly unlikely. As a start, any hydrogen from the target must be vented outside the experimental hall. Since it is a requirement that access to the beam line be possible when liquid hydrogen is present, safety measures must not depend on simply keeping personnel away from the target.

## **DESCRIPTION OF SYSTEM**

FIGURE 1 is a block diagram of the E158 cryogenic system. The system may be logically divided up into the target loop, scattering chamber, small transfer lines, target valve distribution box (TVDB), Triax transfer line and refrigerator. The target loop, scattering chamber, small transfer lines and TVDB are all housed in End Station A with the rest of the E158 beam line while the refrigerator is housed across the street in the Research Yard Refrigerator Facility. The Triax transfer line connects the refrigerator and the TVDB. The

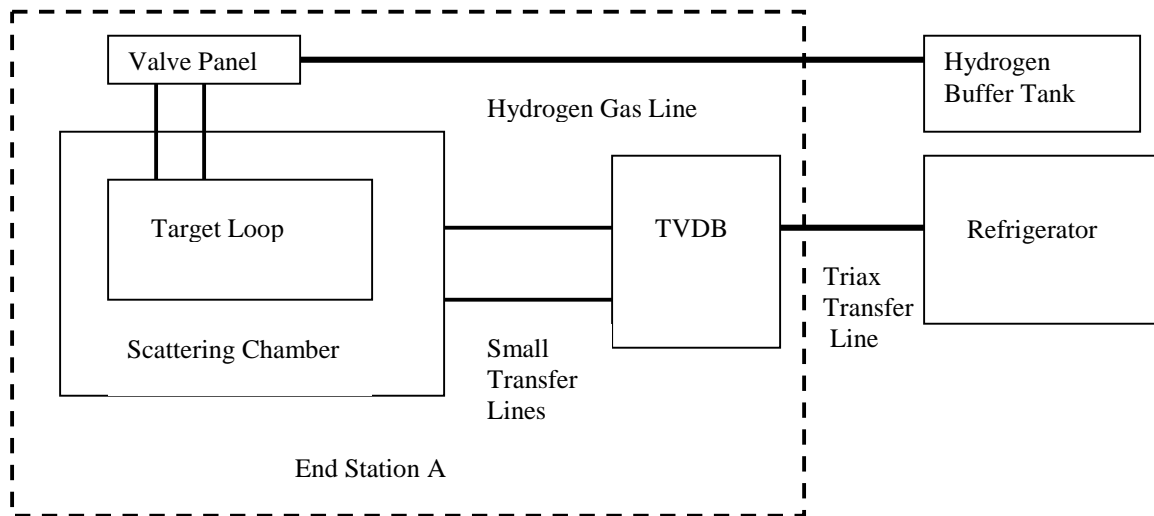

FIGURE 1. Block Diagram of the E158 Cryogenic System

cooling system is closed loop. Helium gas is cooled to roughly 14 K in the refrigerator, sent to the target loop via the Triax transfer line, TVDB and a small transfer line. The helium gas is passed through a heat exchanger in the target loop where it absorbs up to 1 kW. The now roughly 20 K gas is returned to the refrigerator where it is re-cooled via a small transfer line, TVDB and the Triax transfer line.

### Target Loop

The target loop contains the liquid hydrogen and consists of 3 main parts: a target tube, a liquid hydrogen pump and a heat exchanger assembly. The target tube is 1.5 m long and 76.2 mm in inner diameter. The electron beam passes through the center of the tube, along its axis and scatters off the hydrogen flowing in the tube. Wire screens are located inside the target tube to increase the turbulence of the hydrogen and thus reduce the density variations. The liquid hydrogen pump is a vertically mounted centrifugal pump that can move the hydrogen at mass flow rates up to 3 kg/s. This translates into a velocity of 10 m/s in the target tube. A brushless room temperature motor that sits inside the hydrogen space drives the pump at up to 60 Hz. The heat exchanger assembly is a shell and tube system with the liquid hydrogen on the shell side and the circulating cold helium gas on the tube side. The heat exchanger is sized to remove at least 1 kW at 18 K. The heat exchanger assembly also contains a 1 kW electric heater. The power in this heater is linked to the amount of beam energy being deposited in the hydrogen so that the heat load on the cryogenic system is essentially constant regardless of the beam conditions. The target tube, pump and heat exchanger assembly are connected together in a leak tight loop through which the hydrogen is circulated. The loop is constructed of aluminum and stainless steel. Radiation resistant Cernox temperature sensors are installed in the loop to measure the hydrogen temperature. To reduce thermal radiation heat leak to the loop, the outside of the loop is wrapped with 30 layers of aluminized Kapton MLI. Kapton was selected due to its superior resistance to ionizing radiation compared to Mylar. Two pipes connect the loop with the room temperature hydrogen gas buffer tank through a valve panel located in the end station. The panel permits pumping and purging of the loop and contains the over pressure relief valves and burst discs. Two additional pipes connect the cold helium gas

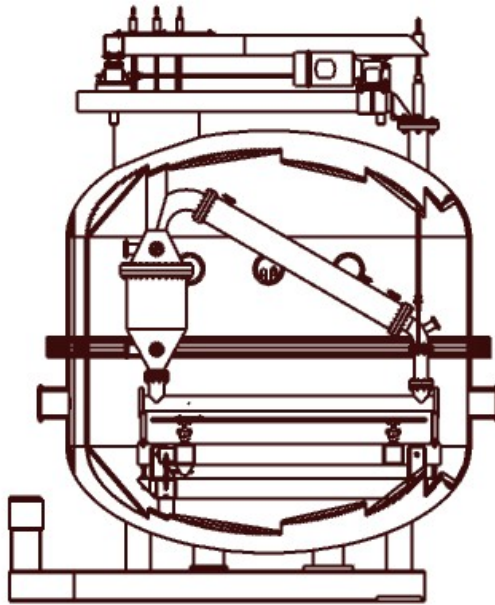

FIGURE 2. Cutaway View of the Scattering Chamber Showing the Target Loop in the Down Position

with the tube side inlet and outlet of the heat exchanger. The target loop is monitored and controlled by a LabView program running on a PC.

### **Scattering Chamber**

The scattering chamber is the cryostat that contains the target loop and provides its vacuum insulation. The target loop hangs from an external frame, which in turn rests on 3 linked motorized jacks. These jacks permit the loop to be lifted up to 150 mm out of the beam line by remote control. When the loop is in its down position it rests on two anvils to fix its location relative to the beam line. Only the target loop is at cryogenic temperatures. The remainder of the scattering chamber operates at room temperature. The scattering chamber also contains a table holding 300 K solid targets used for calibration. The table moves the targets horizontally into the beam line by remote control when the liquid hydrogen target is in its up position. The scattering chamber provides feedthrus for the hydrogen gas lines, the small helium transfer lines, instrumentation, power and connection to the E158 beam line. The scattering chamber is roughly 2 m in diameter and 2 m height. It is expected that parts of the scattering chamber will become radioactive during the experiment. To avoid the presence of isotopes with long half lives, the chamber is constructed from aluminum. There are numerous O rings in the scattering chamber and they are made with the more radiation resistant materials BUNA N and EPDM. FIGURE 2 is a drawing of the scattering chamber with the target loop inside. FIGURE 3 is a photograph of the upper half of the completed scattering chamber showing the target loop.

### **TVDB and Transfer Lines**

Cold helium gas is supplied to and returned from the target heat exchanger via two 23 mm ID vacuum insulated transfer lines that connect the heat exchanger to the Target Valve Distribution Box (TVDB). The TVDB contains valves to regulate the supply and return flow, pressure, temperature and mass flow sensors to characterize the coolant flow, and a 500 W trim heater. This heater allows the fine adjustment of the temperature of the helium sent to the target heat exchanger. The TVDB is linked to the CTI400 refrigerator via a 72 m



FIGURE 3. Photo of Upper half of Scattering Chamber Showing Target Loop

long Triax flexible transfer line manufactured by Kabelmetal. This transfer line contains a 10 mm ID tube for the helium supply flow and an annular space for the return flow. Vacuum spaces separate the two flow streams from each other and from the outside environment.

### **Refrigerator**

A Sulzer/CTI 4000 helium refrigerator provided the necessary 20 K refrigeration. This device was previously used to provide 4.2 K liquefaction and refrigeration as part of the Stanford Large Detector project. A study by H. Quack [2] indicated the addition of a new valve in the cold box would allow the refrigerator plant to provide in excess of 1 kW of cooling at 14 K. The total helium flow rate in the cold box is 100 g/s. This solution would also permit operation of the plant at 4.2 K merely by opening and closing some valves. This flexibility is important as the plant will be used for future 4.2 K experiments.

In addition to adding a new valve, other upgrades were made to the refrigerator. The first heat exchanger (HX1/2) in the cold box had a long standing leak between the high pressure helium and liquid nitrogen streams. This was replaced by an identical leak tight heat exchanger. Additional bayonet connections were installed for future experiments and new temperature sensors were installed. The MLI in the cold box was also replaced. A new control and data acquisition system for the refrigerator was developed. This system, based on a BridgeView program running on a PC, allows monitoring and control of critical aspects of both the refrigerator and the E158 cryogenic system.

After these changes were complete, the refrigerator was installed in its new location across the street from End Station A. FIGURE 4 is a schematic of the upgraded CTI 4000.

### **Hydrogen Safety**

The safety problems associated with the 55 l of liquid hydrogen (LH<sub>2</sub>) in the target were worrisome. Such a large amount of LH<sub>2</sub> had not been used at SLAC for many years. Most of the onsite LH<sub>2</sub> safety experts had retired and the regulatory environment had changed.

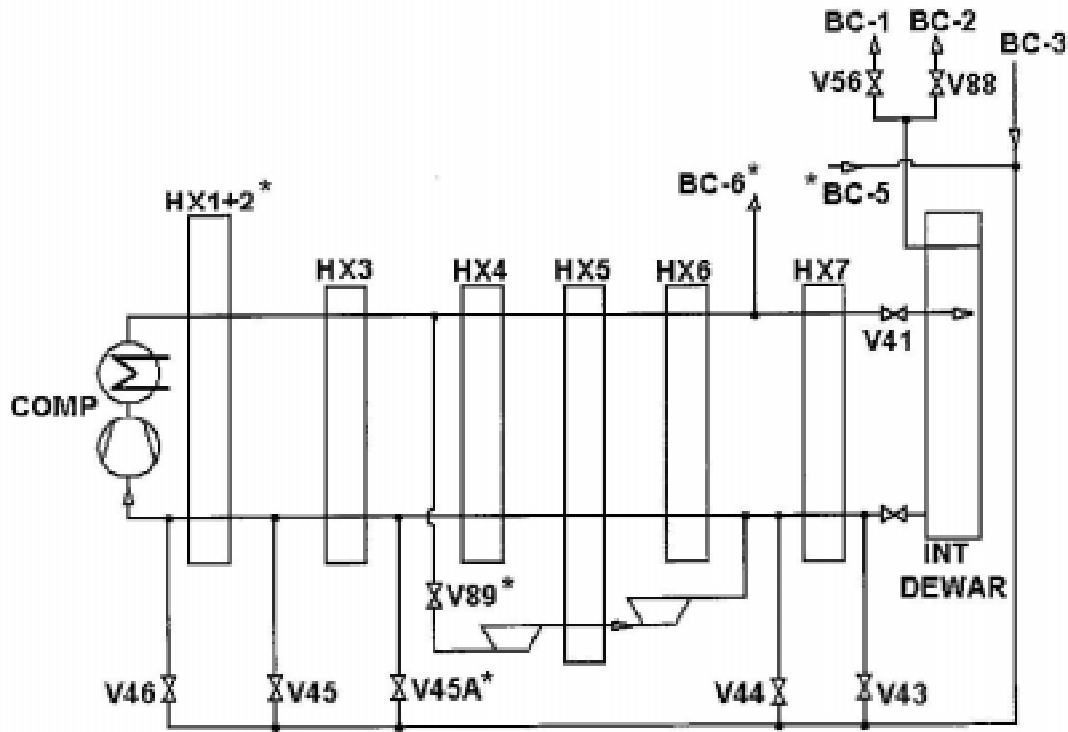

FIGURE 4. Schematic of Upgraded CTI 4000 Refrigerator. \* Denotes New Components

The hydrogen safety aspects of the E158 cryogenic system were extensively reviewed both by the onsite safety committee and by an external panel of hydrogen safety experts. The basic strategy was that in all credible accidents, hydrogen could not escape into an area in which it could detonate and cause injury.

The target loop was designed with redundant burst discs so that in the event of excessive pressure in the loop the hydrogen would vent out the roof of the end station through a 100 mm ID pipe. The relief system was sized so that even in the event of a catastrophic loss of vacuum in the scattering chamber the pressure in the target loop would be at least a factor of 2 less than the tested pressure of the loop. In the event of a catastrophic failure of the target with the LH<sub>2</sub> being dumped into the scattering chamber, the resulting hydrogen gas would vent out the roof through a 160 mm ID pipe. The resulting pressure in the scattering chamber is such that the scattering chamber would contain all the gas. The vent lines are kept filled with nitrogen gas to prevent the formation of explosive mixtures during hydrogen venting. One of the major hazards stems from the scattering chamber being inside a relatively small enclosure for radiation shielding. In order to prevent the build up of hydrogen gas in this enclosure, a continuously operating ventilation fan exchanges the air around the scattering chamber with that of the larger end station.

As a backup to this design, Hazardous Atmosphere Detectors (HADs) are located near the scattering chamber, valve panel and external hydrogen buffer tank. If the HAD system detects the presence of hydrogen gas it: sounds an evacuation alarm, notifies the fire department, turns the end station ventilation fans on to high speed, turns off all the electrical power near the experiment and closes the hydrogen supply valves.

## OPERATING EXPERIENCE

The complete system was first tested at cryogenic temperatures with 20 K helium gas in the target loop. This allowed us to verify that the target loop was leak tight, that the centripetal pump worked as expected and, by putting 1 kW of heat into the target loop heater, that the cryogenic system could remove 1 kW at 14 K. The total heat deposited by the static heat leak and pump work is estimated at no more than 100 W. During this test, quartz windows were placed on the beam line flanges that permitted measurement of the target loop alignment while the target was cold and under vacuum. The results were that the target was aligned to better than 0.4 mm relative to the ideal beam axis when cold and under vacuum. The target was repeatedly raised and lowered and the alignment was found to be reproducible with target movement to within 0.08 mm. Preliminary measurements made after the first physics run in April and May 2002 indicate that the target may have been out of alignment with respect to the beam line by as much as 0.5 mm on each end. This may be due to movement of the scattering chamber as a whole but is still well within the design requirements..

The system was next tested with hydrogen in the target loop. Depending on the refrigerator settings, it takes roughly 6 to 8 hours to cool and fill the target with liquid hydrogen with the target starting at 30 K. The target loop is connected to a 300 K hydrogen gas tank that is in turn supplied by the high-pressure hydrogen tube trailer. All hydrogen liquefaction is done in the target loop itself. Under steady state conditions, the buffer tank maintains the loop pressure at a constant value (typically 0.136 MPa). During the first attempt at liquefaction, the target over pressured and vented even before it was completely full. This was partly due to a mishandling of the buffer tank, but it was also clear that the hydrogen gas supply lines inside the scattering chamber had to be rerouted to allow the target to stably fill with liquid.

After this was done, it was now possible to liquefy hydrogen in the target and keep it there. However, we still saw stability problems. These were associated with the hydrogen pump suddenly slowing down. This may cause the quickly flowing liquid hydrogen to suddenly slow down expand into warmer parts of the loop. As a result, the target loop would over pressurize and vent. This problem was solved by replacing the 1 hp pump motor with a 2 hp pump motor. After this was done, the pump never slowed down and LH<sub>2</sub> could be maintained in the target for more than 2 weeks at a time. FIGURE 5 shows the measured lifetime of liquid hydrogen in the target loop as a function of calendar date. Note that the Y-axis is logarithmic. During a 2 month long physics run held in April and May of 2001, the target only vented 4 times and all of these were due either to problems with either the refrigerator or with the target or refrigerator control computer.

During operations, the loop heater would be automatically regulated by the power deposited in the target by the electron beam. This insured that the cryogenic system would see a near constant heat load in the target loop. At the same time, the trim heater was automatically controlled so that the helium temperature at the inlet to the target heat exchanger was always constant. With these controls in operation, the average temperature of the LH<sub>2</sub> in the loop varied no more than 150 mK over the course of an hour. This longer term stability meets the experimental requirements. The question of whether the hydrogen density changes between beam pulses is still unknown. Problems with noise and backgrounds in the detector prevent a precise measurement. This measurement should be possible in the next physics run.

While attempting to liquefy hydrogen after the last venting event in May 2001, a problem arose. As the hydrogen cooled down and started to liquefy, it appeared as if some sort of resonance was reached and the hydrogen heated up and boiled off. It was possible to overcome this and liquefy the hydrogen by cooling the target loop at a faster rate. Once the



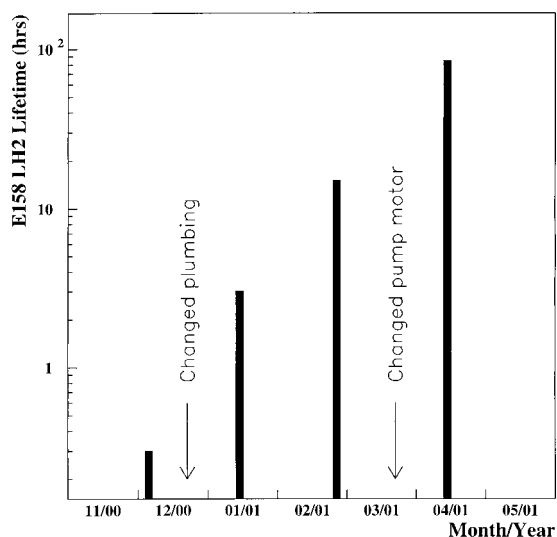

FIGURE 5. LH<sub>2</sub> Lifetime as a Function of the Date of the Experiment

target was full of LH<sub>2</sub>, no further problems were seen. However, there is concern that this problem may be the result of some sort of damage to the target caused by the last venting. Before the next physics run in early 2002, the target loop will be opened up and inspected.

No hydrogen safety problems developed during these experiments. The venting systems performed as designed and no hydrogen was ever released into the experimental hall.

## SUMMARY

An extensive cryogenic system has been developed for the E158 experiment. The system meets the cooling, alignment and materials requirements of the experiment. The cryogenic system provides safe and reliable operation of the liquid hydrogen target.

## ACKNOWLEDGEMENTS

This work would not have been possible without the dedicated support of the SLAC Experimental Facilities Dept. In particular, the cryogenic technicians led by M. Racine and the electronics technicians led by G. Oxoby made major contributions. P. Anthony provided significant assistance in the BridgeView programming. The authors also wish to thank the external hydrogen safety committee: J. Novak, J. Mark and T. Lucas. Work supported by Department of Energy contract DE-AC03-76SF00515 and NSF grant PHY – 0071856.

## REFERENCES

1. Carr, R., et al., "A Precision Measurement of the Weak Mixing Angle in Moeller Scattering", SLAC-Proposal-E158, (1997).
2. Quack, H., "Analysis of the Helium Refrigerator Options for the Proposed E-158 Hydrogen Target Experiment", Consultants Report, (1999).