

# A Fast Luminosity Monitor System for PEP II<sup>☆</sup>

Stan Ecklund, Clive Field\* and Gholam Mazaheri

*Stanford Linear Accelerator Center, Stanford University, Stanford, CA 9309*

Submitted to Nuclear Instruments and Methods in Physics Research

---

## Abstract

The PEP II fast luminosity system provides a measurement of luminosity to the control system with a time constant of 0.3 seconds and fluctuations less than 0.1% for this interval, adequate for use in feedback systems. Continuous visual updates of luminosity are provided. The alignment of the positron beam at the collision point can also be monitored, and there is a visual display of the luminosity associated with each bunch-pair in the machine, sampled approximately every two seconds.

*PACS:* 29.40.Ka; 41.85.Qg; 07.50.-e

*Keywords:* Luminosity; Radiative Bhabha

---

<sup>☆</sup> Work supported by U.S. Department of Energy, contract DE -AC03-76SF00515

\* Corresponding author: Tel.: 1-650-926-2694; fax: 1-650-926-4178.  
*E-mail address:* [sargon@slac.stanford.edu](mailto:sargon@slac.stanford.edu)

## Introduction

It was realized during the design period [1] that a fast luminosity measurement would be very beneficial in the operation of the PEP II collider at SLAC [2]. The measurement system was planned as a way to measure the performance of the machine, and report it to operators fast enough that it could be used in tuning procedures. In addition it was hoped that an indication of the luminosity yield of individual bunch pairs could be obtained. A further refinement was to give some indication that the collision axis was directed stably along a fixed direction.

PEP II has been operating for more than a year. Together with the KEKB collider at KEK, it represents a new generation of electron-positron colliders. It is concentrating on the production of particles with the b-quantum number in order to elucidate the processes associated with the violation of CP. In order to do this, the machine collides the electron beam at 9 GeV with the positron beam of 3.1 GeV. Statistics of  $> 10^8$  events will be needed and so the design luminosity is high,  $3 \times 10^{33} \text{ cm}^{-2} \text{ sec}^{-1}$ . The rings have been running with up to 1.4 Amps of positrons and 0.7 Amps of electrons, which are distributed in a large number of bunches around each ring. Although designed for 1658 filled bunches, at present the machine delivers its best luminosity at an empirically established filling pattern with typically about 40% of this number.

The most appropriate interaction for the luminosity signal is the radiative Bhabha process, sometimes referred to as single Bremsstrahlung, where a hard gamma ray is emitted in the glancing collision of an electron with a positron. The photon is emitted with a Bremsstrahlung-like spectrum, approximately  $1/E_\gamma$ , where  $E_\gamma$  is the gamma ray energy, and a narrow opening angle  $\sim 1/\gamma$ , the inverse of the relativistic Lorentz factor. This cone is smaller than the  $\sim 350 \mu\text{rad}$  divergence of the beam at the PEP II collision point. If a forward-direction aperture of cone half angle about 1 mrad is kept free, a detector can intercept this signal.

This process is frequently used at electron-positron colliders [3]. The rate is believed to depend mildly on the beam spot shapes of the colliding beams, explained either by a transverse cutoff of the overlap between the beam distribution and the extended field, or in terms of a longitudinal screening cutoff [4]. The typically small vertical spot sizes at PEP II are estimated to suppress the rate by a few percent. For purposes of a fast response counter, an uncertainty in the yield at the few percent level is unimportant as long as it does not vary strongly as the beams are tuned.

## Design and Layout

The clear aperture in the beam pipe for emission from the positron beam ends at a water-cooled vacuum wall, 8 m from the collision point, at a near grazing angle of  $5^\circ$  to the flight direction. Specially designed to absorb up to 15 kW of synchrotron radiation power from the beam, this aluminum structure is effectively 1.6 radiation lengths thick, and the radiative Bhabha "spot" is spread along about 15 cm of it. By comparison, the beam pipe downstream from the electron beam must be able to absorb up to 70 kW, is fabricated of thick copper at about  $1^\circ$  to the collision axis, and, at about 40 radiation lengths, prevents the detection of radiative Bhabha scattering on that side.

The endpoint of the gamma ray spectrum from the positrons is obviously 3.1 GeV. The

rate of gammas above 1 MeV per pulse at nominal luminosity is about five per pulse, but the low energy component is largely absorbed in the thick material of the beam wall and a 4.5 radiation length lead converter plate that rejuvenates the shower just in front of the detectors. The peak contribution to the detector signal comes from photons of about 400 MeV. In a year of nominal operation, the signal deposits close to 1GRad in the detector.

The detector medium is high quality fused silica [5]. Such material has been shown to be very tolerant of radiation [6]. Used to generate Čerenkov light, it also is less sensitive than ionization detectors to synchrotron radiation and very low energy electron backgrounds from lost beam particles. Several counters are in the package, all using the same principle. The block of fused silica is 2.7 cm thick along the shower direction. The Čerenkov light is emitted at  $47^\circ$  to the directions of the charged particles, which have a broad angular range about the forward direction. A fraction of the light is propagated by total internal reflection across the 6 cm transverse dimension of the block. At the end away from the beam pipe, the silica face is cut with its normal at an angle of  $35^\circ$  to the transverse axis, the angle which simulations showed was optimum for the collection of light from the shower. An air light pipe, about 12 cm long with polished aluminum walls, helps guide light to the face of a photomultiplier tube. In the package, the first fused silica block is 5 cm tall, and totally contains the transverse dimension of the shower. Its photomultiplier tube is in the horizontal plane, and is a 2-inch diameter R3377, chosen for its short pulse widths [7]. Behind this is a similar counter, but with two R5600 tubes viewing the Čerenkov light [7]. Their photocathode diameters are only 8 mm, but they are even faster than the R3377. Next in line is a 3-element hodoscope with counter elements spaced at 11 mm, set up to monitor the horizontal profile and position of the shower. These counters are also viewed by R5600 tubes. Finally a similar hodoscope records the vertical profile of the shower.

An illustration of the layout is given in Fig.1. It should be appreciated that the counters are surrounded by heavy lead shielding (not illustrated) except where the signal enters, and between the beam pipe and themselves, where space constrains the thickness to be only 1 cm. (Note that this is the pipe for the incoming electron beam.) The shielding forms part of the personnel protection system at the interaction region.

## Signal Characteristics and Electronics

The primary responsibility of providing a signal proportional to the luminosity is carried by one of the tubes in the second counter. The anode current is taken via RG214 cable directly outside the shielding wall. At the external electronics station the signal is presented to a load resistor, and then integrated in a simple network that includes the input capacitance of a 14 bit multichannel digital voltmeter. This CAMAC unit (Smart Analog Module or SAM) is part of the PEP II data collection system. In practice, two of these modules in parallel are used for various services. The effective load resistance, including the back termination at the tube, is  $300\text{ k}\Omega$ , and the signal decay time is about 0.35 seconds, just fast enough for the feedback loops that use luminosity [8].

The hodoscope counter signals are recorded similarly. However, for the bunch by bunch signal information, a different scheme was needed. It was difficult to provide both high-speed and very low-speed types of signal from a single source, and so independent p.m.t.s provide the

high speed data stream. The electronics for this are based on digital techniques.

Signals from the tubes are transmitted over 8 ns of RG58 cable to a shielded enclosure below the counter shielding. Here they are amplified in two stages, the first based on a fast Elantec Semiconductor Inc. EL2075c 2-GHz gain-of-ten op-amp, the second an amplifier from Phillips Scientific [9], model 6950, rated at 300 MHz but with a 2.5V amplitude range. The signals are split in the ratio of 10:1, and both fractions are passed immediately to discriminators whose thresholds are remotely controlled. The discriminator output signals are carried on RG214 cables through the shielding walls to the electronics station. Total cable lengths are about 30 m.

The discriminators are 400 MHz time-over-threshold devices based on LeCroy Corp. MVL407 chips [10]. At PEP II their thresholds can be set as low as 5 mV, and the minimum pulse width before loss in amplitude is about 1.5 ns. These signals are reshaped and standardized in length by standard NIM discriminators and coincidence modules which also provide multiple copies. Several functions are then implemented. One channel is widened and integrated by a NIM-format active integrator using Analog Devices Inc. AD645 and AD611 chips. This provides a level with a time constant of about 0.25 seconds which is recorded by the same CAMAC SAM to correlate with the main luminosity signal as a diagnostic. In fact, since the signals are passed through NIM coincidence units, and timing gates as narrow as 2 ns can be applied using a custom pulse generator remotely controlled by the PEP II timing and control systems, the luminosity of individual bunches can be selected and followed.

A similar integrated signal is AC coupled to an oscilloscope, where the effects of feedback and other changes at the 1% level can be monitored by operators [11]. The statistical and other sources of noise are below  $10^{-3}$  of the signal. The 100-second differentiation time constant is arranged to suppress the large but slow luminosity changes during filling or coasting of the beams. On the other hand, signal changes in the 0.1- to 10-second timescale are readily observable on the display, which scrolls at 1 division per second.

Note that a counting rate, or a signal derived from it like this one, will not in general be linear with respect to the luminosity. This is because of Poisson statistics of the several gamma ray signals breaking through to the counter from the same bunch, and the pile-up of these simultaneous signals at the discriminator, which together are not linear with luminosity. This was studied by simulating the process, including the electromagnetic shower. The probability of a single gamma punching through to produce light and generate a photoelectron from the photocathode is very low in the MeV range but increases strongly with energy. It was seen that, if the threshold were set to pass 26% of the gammas that **did** produce a photoelectron signal, the discriminator rate would be acceptably linear over a wide range of luminosities per pulse (Fig. 2). The thresholds were set like this while the luminosity was low.

Full rate pulses from a second channel of the discriminator are sent to BaBar, the b-physics detector at PEP II, for use in dead-time studies. Another copy is used for a display of the luminosity for each bunch in the machine, which is described separately below.

## Operating experience

At the beginning of operations, with low luminosity, before the detector BaBar was in place, a means of calibration of the counter was worked out. This was based on knowledge of the

cross section and energy spectrum of the gamma rays, simulation of the development of the shower in the beam pipe and converter materials, and studies of the detector in a test beam at SLAC. The performance of the system, including the effects of the Poisson distribution of the initial signal, was simulated. The calibration was later confirmed by the BaBar group, but as luminosity and exposure time increased dramatically after BaBar installation, the signal was seen to be fading by comparison with the BaBar slow luminosity measurement based on wide angle Bhabha, dimuon and gamma-pair rates. At that time, the first counter in the package, with the 2-inch p.m.t., was being used as the main monitor. The loss in sensitivity is attributed to deterioration of this tube, and was about a factor of two in the luminosity signal after about 250 Coulombs of charge delivered from the anode. This premature aging may be ascribed to the fact that a very fast linear dynode device like this must maintain very tight focusing of the electron beam in the dynode structure, causing accelerated wear.

The response to this was to make use of one of the small R5600 tubes for the luminosity signals. In tests before installation, a sample was tested at 70 microamps anode current while delivering 660 Coulombs with variations in the output of no more than  $\pm 10\%$ . These devices spread the dynode current across many apertures in dynode foils, and also keep the dynode beam power down by running at relatively low voltage. In addition, we have worked to keep the anode current down to a few microamps at the design luminosity. For comparison, the 2-inch tube, as initially installed, would run at about 100  $\mu\text{A}$  at design luminosity. Since future luminosities can be expected to exceed the design value, it is necessary to be conservative.

Aside from this, the system has performed quite well. An indication of the stability of the calibration is given in Fig. 3, where the ratio to the low statistics BaBar run-by-run result is histogrammed for a period of three weeks. Fig. 4 shows a comparison of the main counter and one of the hodoscopes. The data were drawn from the history collected every six minutes by the PEP II control system. The quality of the linearity and the resolution can be judged from the figure. A similar comparison of the main (direct analogue) and alternative (discriminator with correctly set level) channels is shown in Fig. 5. A view of the scrolling display showing the effects of feedback operations is seen in Fig. 6. An indication of the ability of a hodoscope to track positron beam steering changes is given in Fig. 7. Finally, a sampling of the luminosity at 6-minute intervals throughout a day is plotted in Fig. 8.

### **Luminosity displayed for each bunch**

With a large number of bunches populating the ring, there is a possibility of interactions between them causing systematic losses in luminosity for some of the bunches. For such reasons a method has been developed for monitoring the relative luminosity for each bunch in a time useful for operators. Frequent sampling was emphasized over high precision. The work described is based on a prototype unit whose performance is limited by construction techniques and available effort, but is nonetheless fully functional and has been in use continuously, with occasional improvements, for more than six months.

The principle is based on the concept, described above, of measuring luminosity by counting pulses above a given discriminator threshold level — the same pulse stream is used. For example, if a given bunch yields a signal from the discriminator for one turn in ten, then by

counting, say, 4000 turns, a statistical uncertainty of 5% is achieved. This would require less than three milliseconds. It could be done for several bunches simultaneously. In fact a 32-channel CAMAC scaler was available to us — counting 32 channels at a time would allow the complete ring with nominal bunch spacing to be handled in 52 segments, or 1.5 seconds plus readout time.

In order to accomplish this, the data stream is presented to a shift register, where it is shifted along at the bunch frequency, driven by the PEP II timing system. The timing system also produces a pulse every turn, tied to a selected bunch. This is used, with an internal counter, to select the correct starting bunch for the current 32-bunch set, every turn. After counting 32 successive bunches from the selected start, the shifting is stopped, and the contents of the shift register, that is, those bunches which registered a “hit” during that turn, are shifted out in parallel to the 32 channel scaler. The system is then prepared to repeat the exercise until the requested number of turns has been satisfied. At that time the scaler channels are read out via CAMAC to a PC, which selects the next set of 32 bunches to be studied, and restarts the process. The PC continuously updates its graphical display of the luminosities, and sends the screen image over the accelerator video network.

Some compromises had to be made in practice, particularly because of the prototype nature of the unit, which was made by soldering wires between components glued to a board. The unit could not work at the full 238 MHz, corresponding to the 4.2 ns nominal bunch spacing, and so it is run at half of this. Counter signals falling between the 8.4 ns strobes are ignored during the first pass through the ring bunches, but then a second pass, with its timing offset by 4.2 ns, collects data from the alternate bunches. This principle has, in fact, been extended to account for bunch patterns that are spaced by odd numbers of the 2.1 ns-spaced RF buckets, something not specified for the original implementation of the unit, but subsequently introduced as a possible operating mode at the storage rings. At present four passes are taken with the 8.4 ns “comb”, with the timing of each pass offset by 2.1 ns. Although sacrificing a factor of two in time, this allows for any arbitrary bunch pattern.

The circuit and its function are presented schematically in Fig. 9. The main CAMAC unit is complex and need not be described in complete detail here. It is based on the Motorola Inc. high speed ECLinPS series of logic components. Principal components shown include controllable delay chips, MC10E195, shift register MC10E141, and counters MC10E136.

An illustration of the display is given in Fig. 10, showing a repeating pattern of subtrains of bunches spaced at 6.3 ns, alternating between 9 and 10 bunches per subtrain. The gaps of 50.4 and 44.1 ns between subgroups are used to prevent the build-up of bunch-to-bunch resonant effects. Note that there is always at least one longer gap in the bunch train around the ring, part of which shows at the beginning of the display, the rest at the end. This gap is required to allow the dispersal of the ion build-up in the electron beam’s potential well.

The system runs continuously. Since it depends on the relative timing of signals from the PEP control system and from counters that, in turn, reflect the bunch timing in the machine, we have experienced some timing drifts, much less than 1 ns, apparently temperature related, which require occasional manual adjustment.

It should be realized that the photomultiplier tubes themselves, although fast enough for this operation, do not have much to spare. We have observed, at peak luminosity, that 25% of signals have enough amplitude to drive a pulse longer than 4 ns from the discriminator. If the

bunch spacing were 4.2 ns, a long pulse would interfere with the signal, if there were one, from the next bunch, since the discriminator would not reset between them. After the long cables, the discriminator signals are reshaped and standardized to 2 ns width, and consequently signals from following bunches would be lost. Of course, if the luminosity were the same with 4.2 ns spacing as with 8.4, the closer spacing would mean a reduction in luminosity per bunch by a factor of two. In turn, the bunch occupancy rate and the overlap fraction would be reduced to keep this inefficiency below the 5% level. However, at higher luminosities, with 4.2 ns bunch spacing, the effect would become important.

## **Outlook**

The system described has evolved with time and experience. As luminosity increases and machine requirements change in the future, it can be expected that further modification will be necessary. Depending on the bunch pattern that is used, the digital signals may be affected significantly by dead-time as described above. Faster p.m.t.s would be the preferred solution for this, but operating in a mode nonlinear with luminosity may prove to be an acceptable alternative, applying correction factors by appropriate means for the various uses. Eventually luminosities may be an order of magnitude higher than at present, with a demand for even higher operational efficiency than now, and p.m.t. linearity and lifetime will again become an issue.

It is planned to replace the prototype bunch-by-bunch display system with a version based on a printed circuit board, and it is expected that this will operate at 238 MHz, speeding up its scans by a factor of two. This is an essentially real time system that stands alone at present, and making its data available digitally on demand to the PEP II control system remains to be accomplished.

## **Acknowledgments**

We have benefitted from discussions with many people during the development of this system, including John Seeman, Uli Wienands, Hobe DeStaebler, Mike Sullivan, Franz-Josef Decker and the other PEP II physicists, and Valery Telnov. We particularly wish to thank Ralph Nelson for some of the EGS4 simulation studies. The construction of the miniature p.m.t. bases and some very complex electronics modules was done with great skill by Karl Bouldin.

## References.

- [1] H. De Staebler, "Fast Relative Luminosity Monitor", SLAC-ABC-56, Dec 18, 1991.
- [2] PEP II Conceptual Design Report SLAC-418 (1993).
- [3] A.E. Blinov et al, Nucl. Instr. and Meth A273 (1988) 31; M. Greco et al., Phys. Lett. B318 (1993) 635; C. Bini et al., Nucl. Instr. and Meth. A 349 (1994) 27.
- [4] G.L. Kotkin et al. Phys. Lett. B221 (1989) 96; A.E. Blinov et al., op.cit.; R.Kleiss and H. Burkhardt, CERN SL/94-03 (OP).
- [5] The material used is Spectrasil, trademark of TSL Group PLC, Wallsend, England.
- [6] B. Grosdidier, CRN 92-45 (1992); D. Lazic, CRN 93-48 (1993).
- [7] Hamamatsu Photonics K.K., Hamamatsu City, 430-8587, Japan.
- [8] L. Hendrickson et al., "Slow Feedback Systems for PEP-II", SLAC-PUB-8480, June 2000.
- [9] Phillips Scientific, Ramsey, New Jersey 07446, U.S.A.
- [10] LeCroy Corporation, Chestnut Ridge, New York 10977, U.S.A.
- [11] We are grateful to Artem Kulikov for this suggestion.



## Figure Captions:

- Fig. 1. Layout of the counter package. The cooled beam pipe exit wall is shown, followed successively by the shower converter, the first counter, with a 2-inch p.m.t., the second counter with two small tubes, and two hodoscopes. The lead shielding that surrounds the package is not represented in the drawing.
- Fig. 2. Simulation of the response of a system based on counting pulses from the discriminator, against single pulse luminosity up to the design value for PEP II. Responses for various discriminator pass rates are plotted, and the fractions of non-zero pulse heights above the threshold corresponding to each curve are shown on the right.
- Fig. 3. Histogram of the ratio of the luminosity measurements from BaBar runs to the results from this counter over the same intervals, recorded over a period of three weeks. The mean is  $1.007 \pm 0.002$ , and the RMS width is  $0.023 \pm 0.001$ .
- Fig. 4. The analogue signal from the main luminosity counter compared with that from one of the hodoscopes. The plot is from samples taken every six minutes during an eight hour interval.
- Fig. 5. Correlation of the analogue signal and the signal from the discriminator system, sampled every 6 minutes over a 12 hour period.
- Fig. 6. On-line oscilloscope display showing the effects of the feedback dithering on luminosity.
- Fig. 7. Reconstruction of the changing horizontal angle of the positron beam over a ten hour period, inferred from the hodoscope.
- Fig. 8. Illustration of the luminosity history, sampled every 6 minutes over a day. The ordinate scale is in luminosity units of  $10^{33} \text{ cm}^{-2} \text{ sec}^{-1}$ .
- Fig. 9. Schematic illustration of the functioning of the bunch-by-bunch luminosity monitoring electronics. The luminosity signals first pass through the CAMAC controlled delay unit, where offsets in increments of 2.1 ns are applied. The components following the 476 MHz signal input represent: conversion to ECL pulses; frequency division by 4; synchronization with the once-per-turn fiducial signal ("Start"); counting 32 pulses. The components following the Start input signify: conversion to ECL; conversion to TTL; counting the requested number of turns. Only four of the 32 outputs from the four 8-bit shift registers are shown.
- Fig. 10. On-line display of luminosity, bunch by bunch. The luminosity amplitudes are plotted as vertical lines for all the bunch-pairs in the rings, in six sequential rows. When this was recorded, the bunch spacing was 6.3 ns, with subgroups alternating between 9 and 10 bunches. The gaps between subgroups are intended to reduce ion build-up and bunch-to-bunch resonant effects. A missing bunch can be seen in subgroup 13.

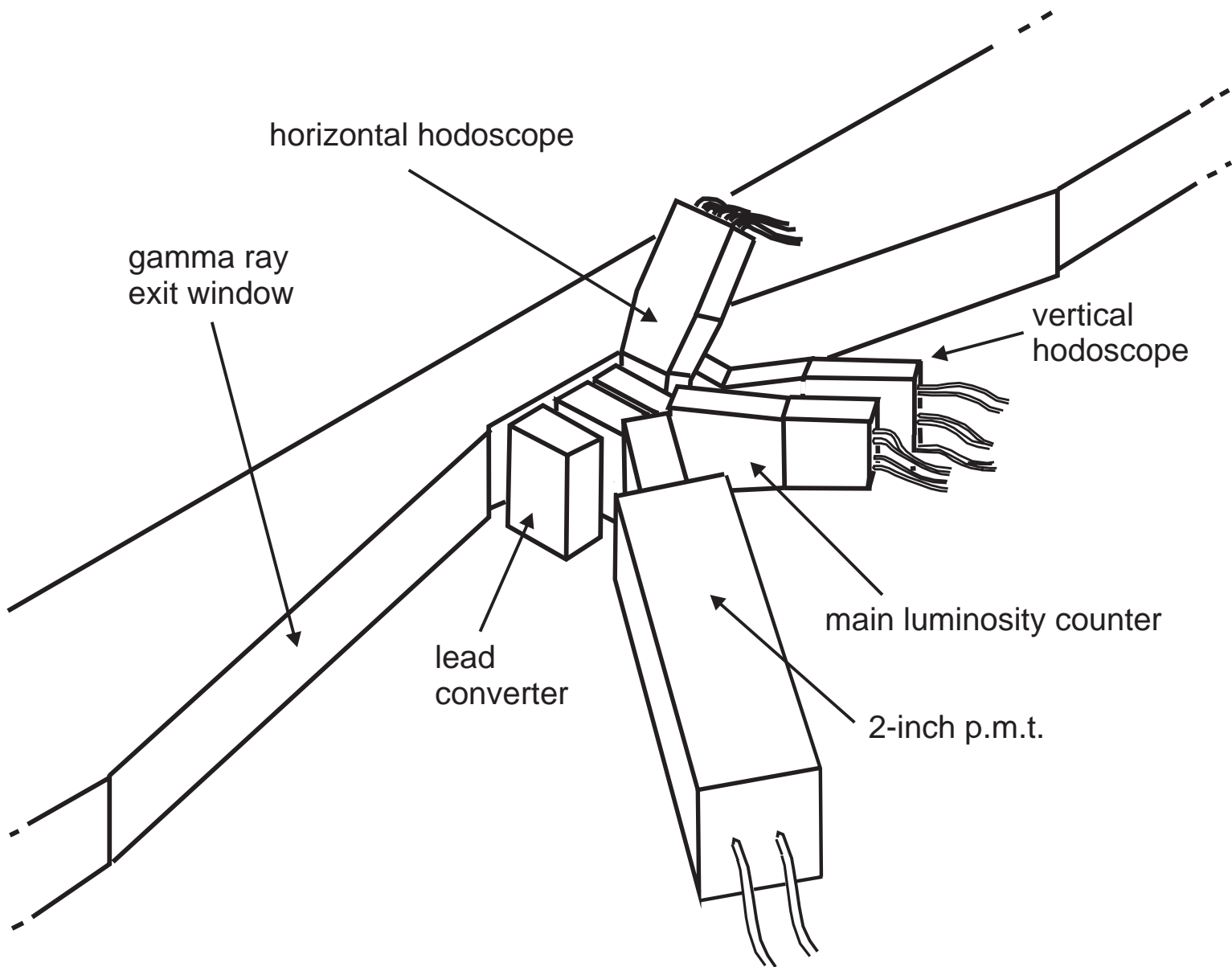

Fig. 1

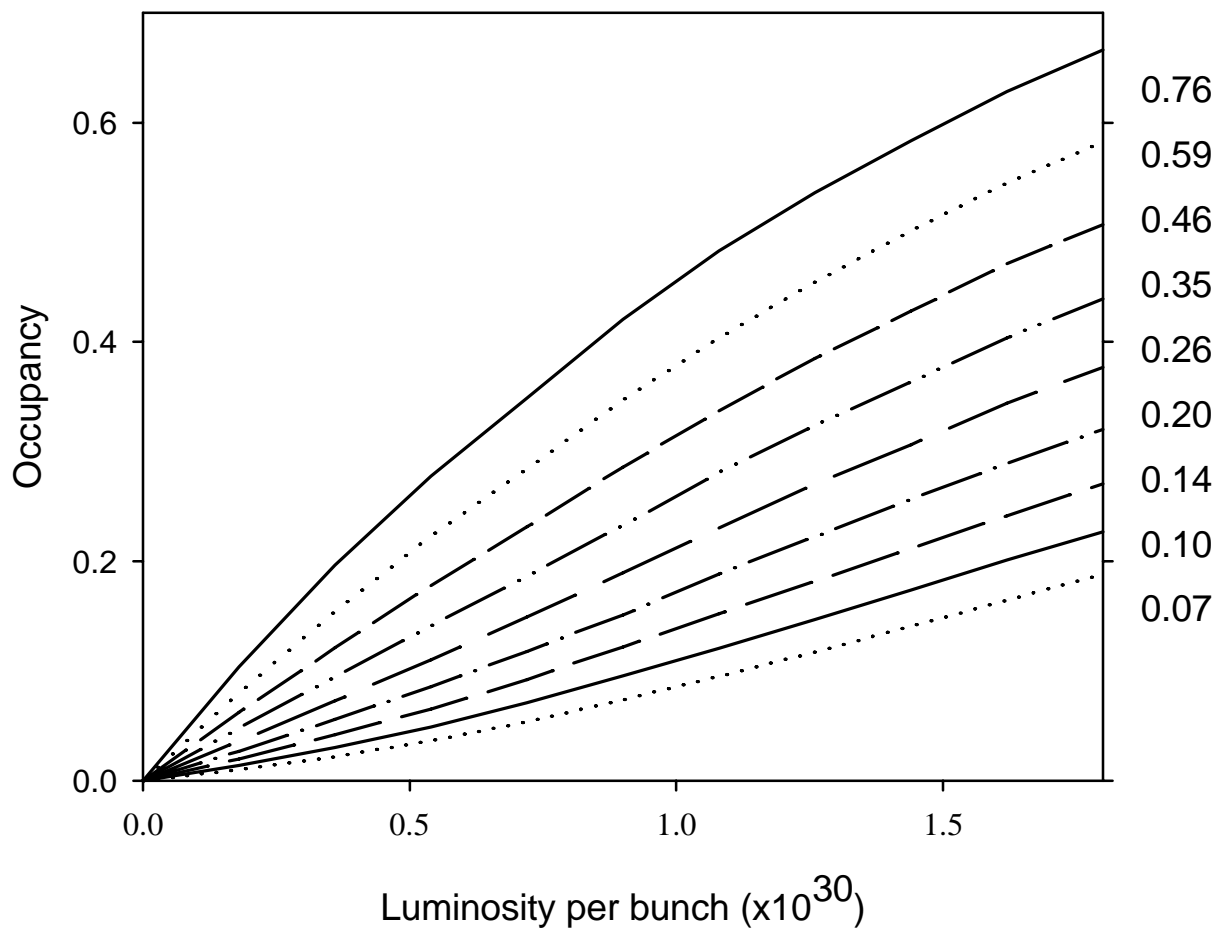

Fig. 2

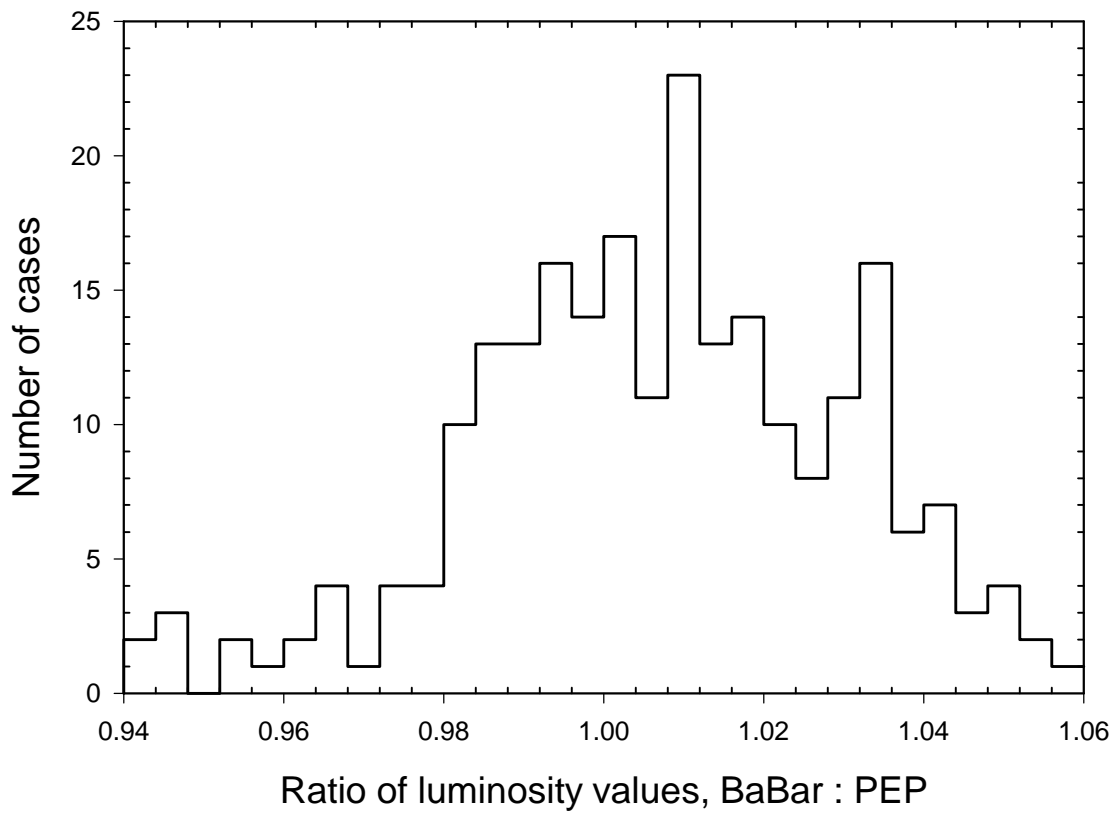

Fig. 3

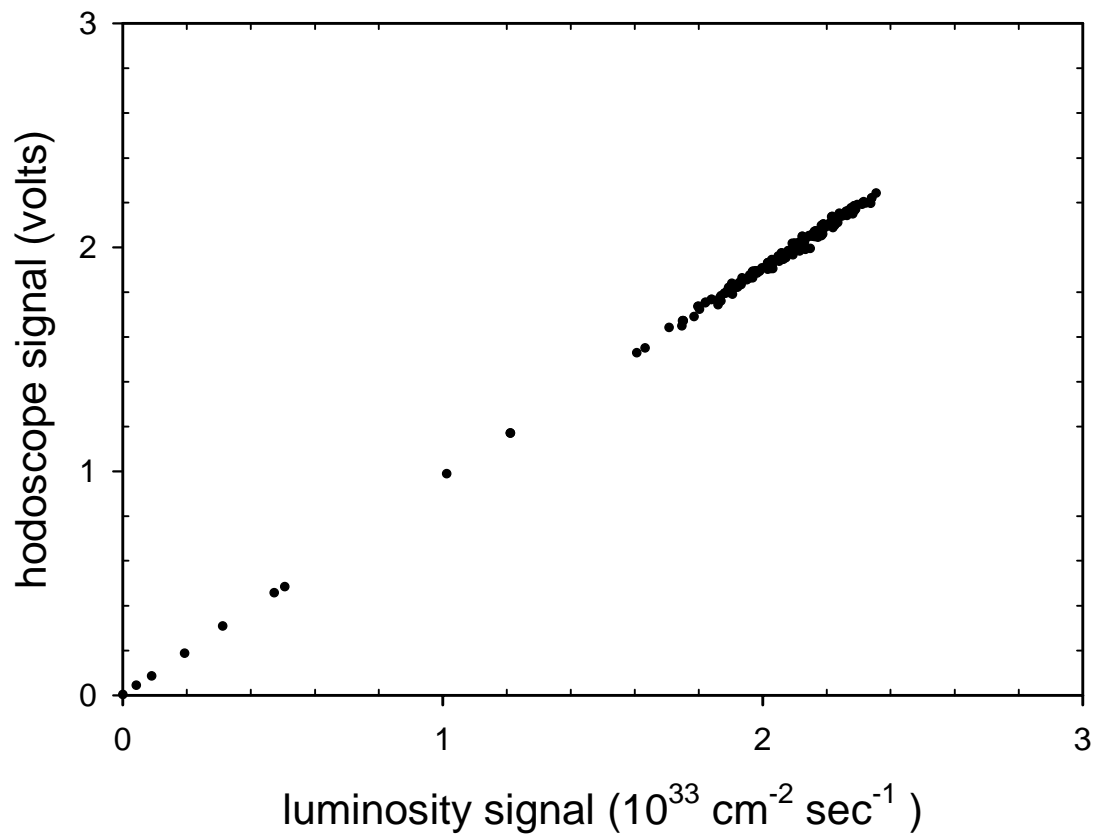

Fig. 4

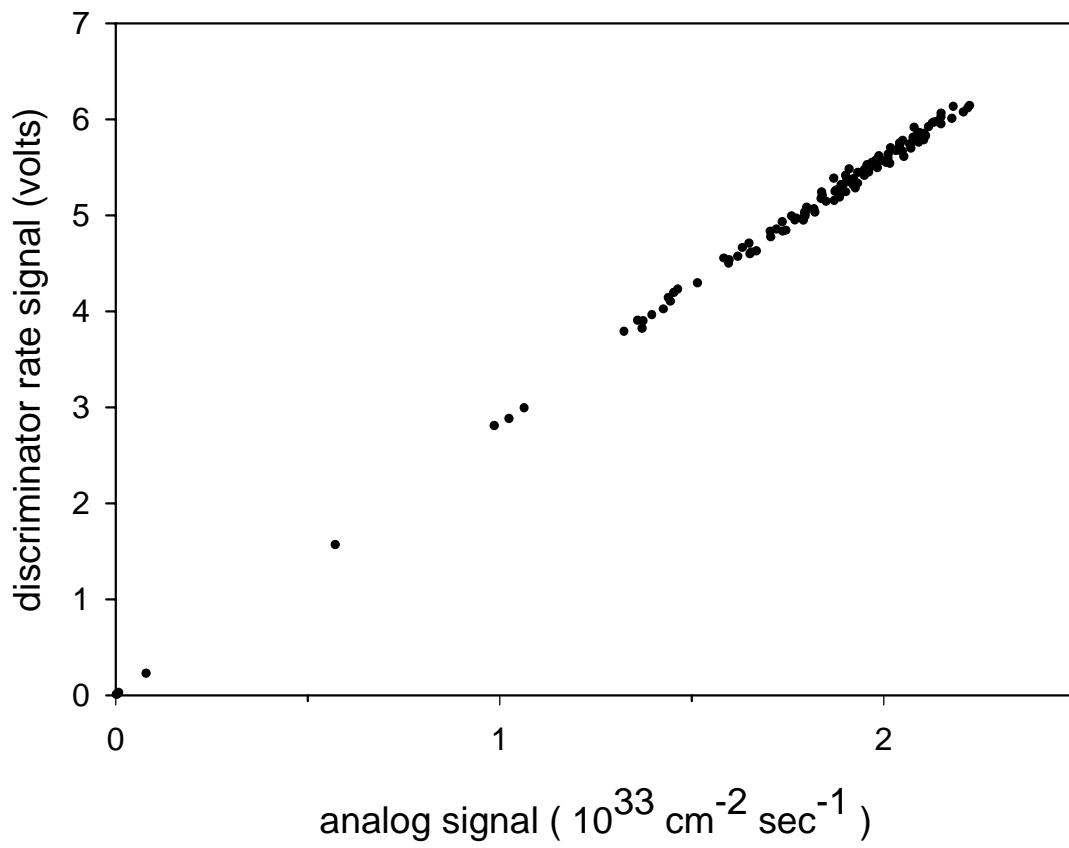

Fig. 5

Tek Stop: 100 S/s

16 Acqs

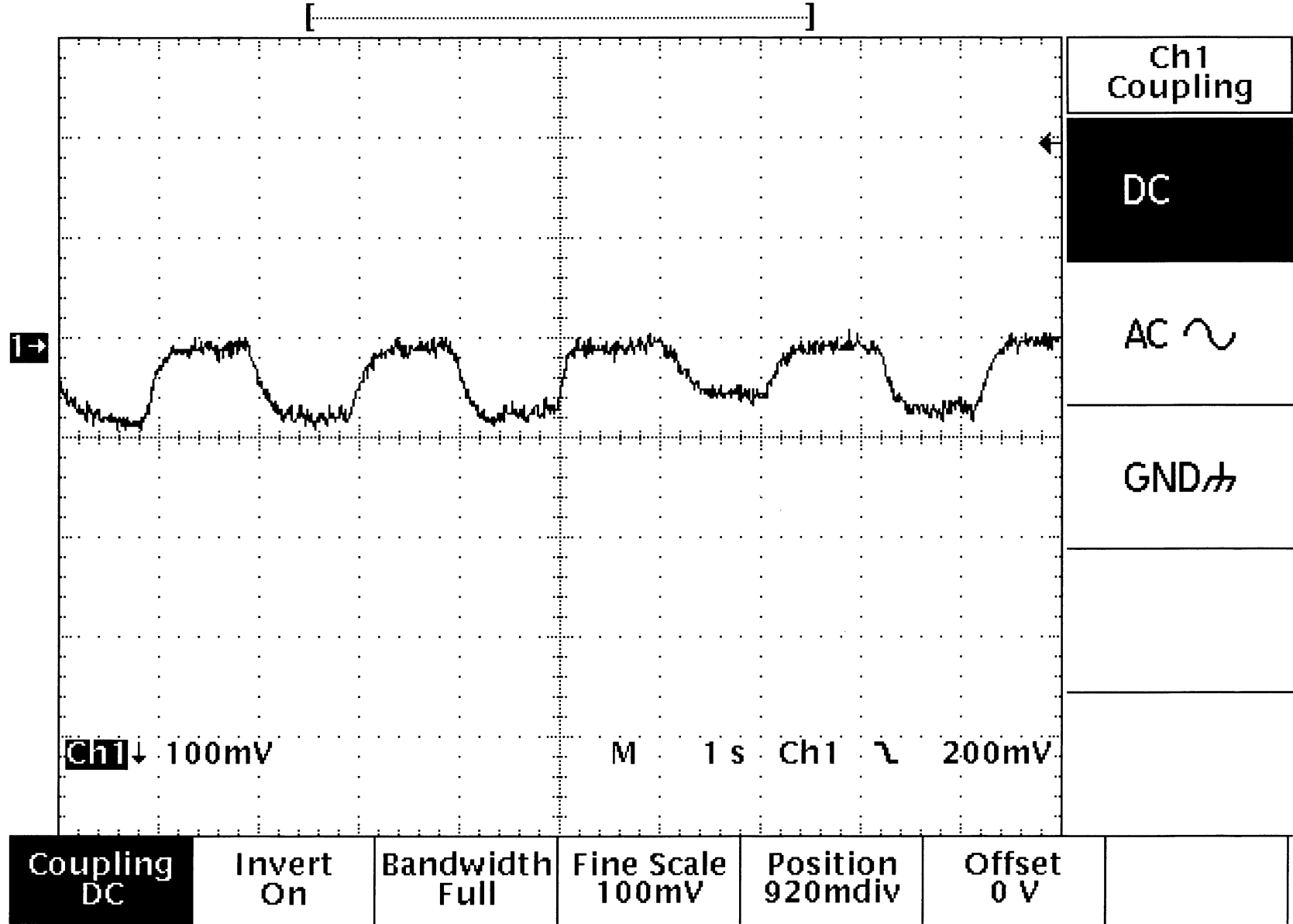

Fig. 6

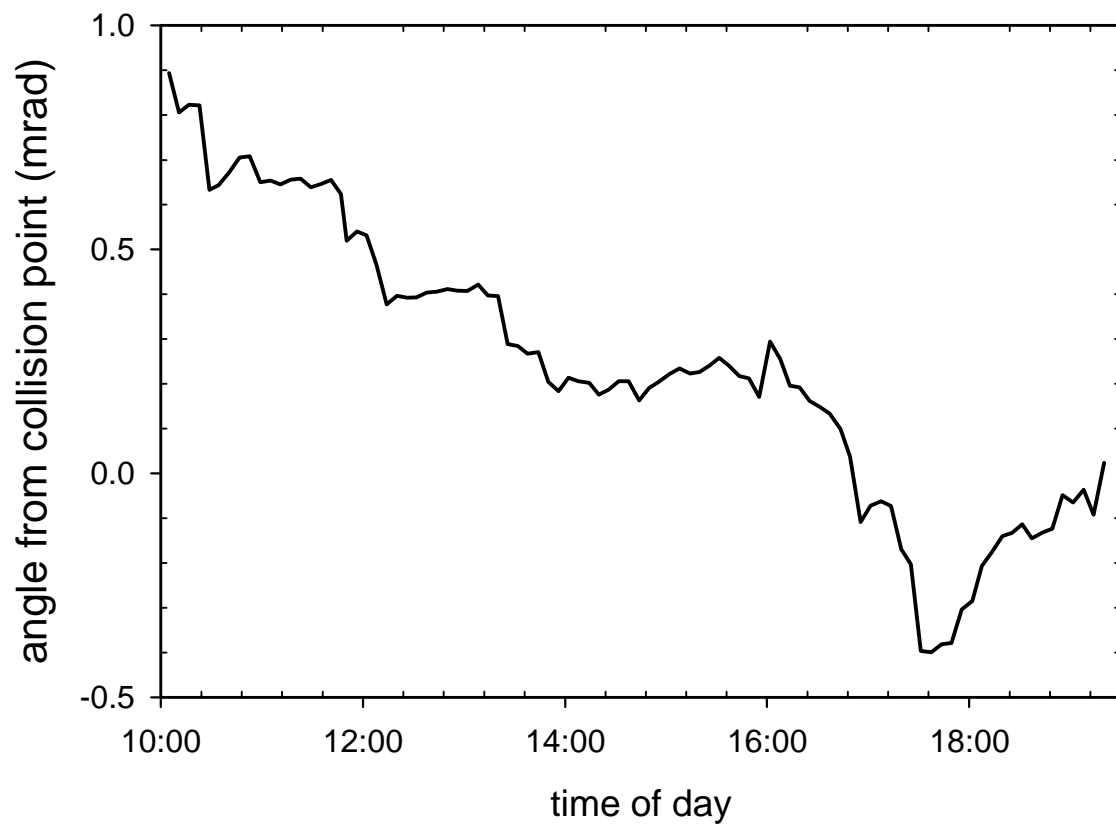

Fig. 7



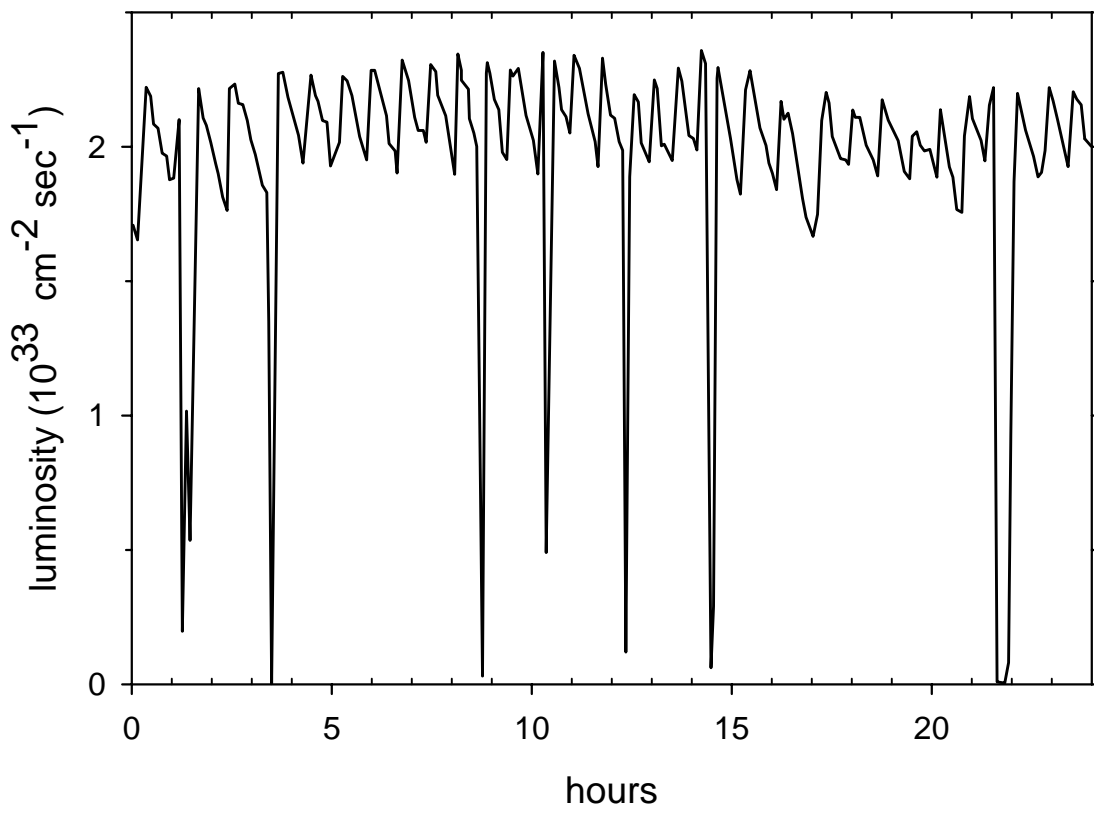

Fig. 8

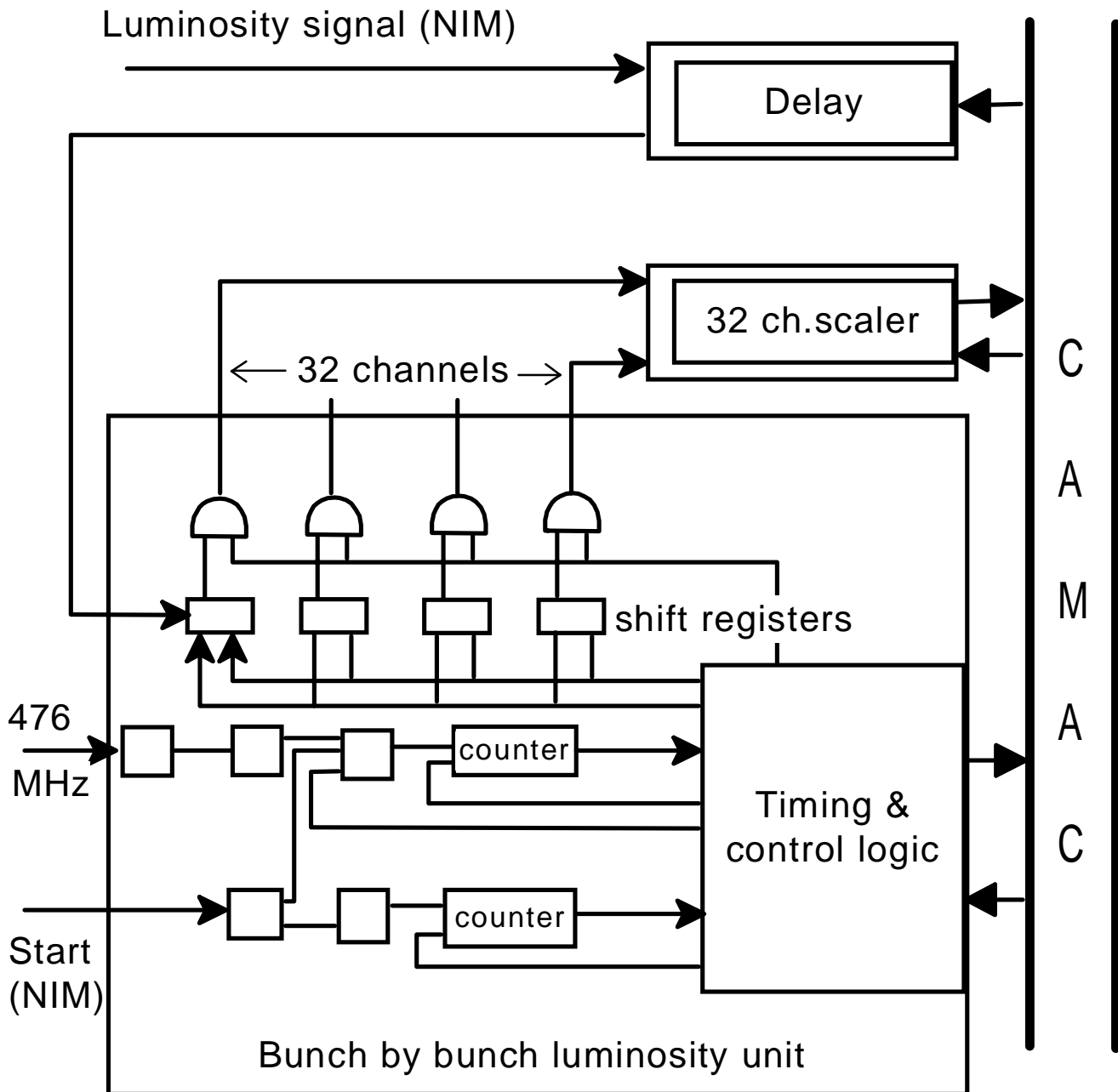
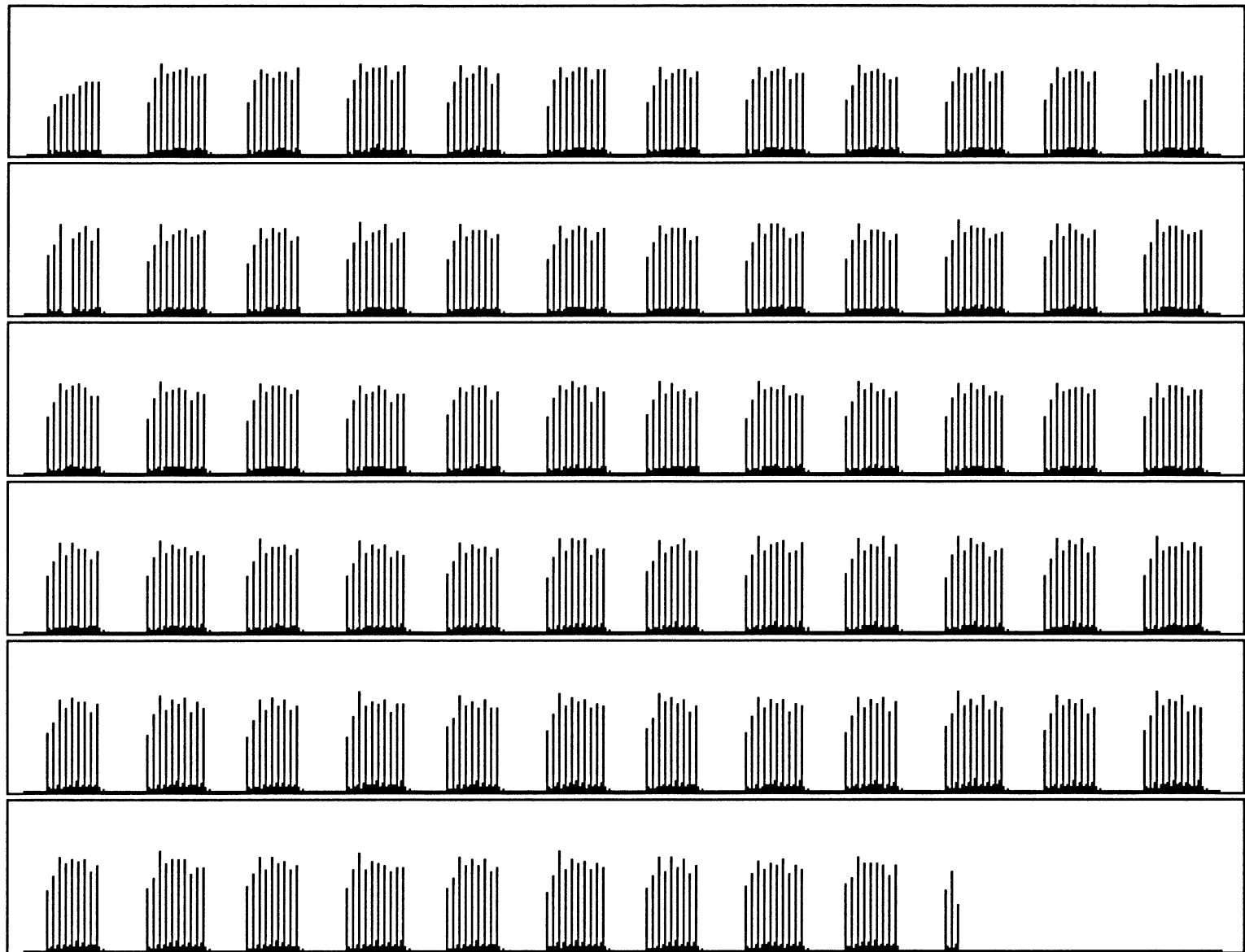

Fig. 9

5



scale \* 50 / 2017

10/26 17:28

Fig. 10