

Accelerator Diagnostic Techniques Using Time-Domain Data from a Bunch-by-Bunch Longitudinal Feedback System.

D. Teytelman, R. Claus, J. Fox, H. Hindi, R. Larsen, I. Linscott, S. Prabhakar, W. Ross, A. Young
 Stanford Linear Accelerator Center, P.O. Box 4349, Stanford, CA 94309

A. Drago, M. Serio

INFN - Laboratori Nazionali di Frascati, P.O. Box 13, I-00044 Frascati (Roma), Italy

G. Stover

Lawrence Berkeley National Laboratory, 1 Cyclotron Road, Berkeley, CA 94563

Abstract

A programmable DSP-based longitudinal damping system has been developed for the PEP-II/DAFNE/ALS machines. The DSP-based architecture allows feedback functions to coexist with data acquisition or instrumentation algorithms. The fast sampling rates in these systems (500 MHz) in conjunction with the large distributed memory of the DSP processors make possible several novel beam diagnostics complementary to traditional narrowband spectral measurements. Instantaneous spectral measurements of 250 MHz span with 70 Hz resolution can be made from 14 ms time domain data records captured by the DSP system. We present techniques developed for the measurement of modal growth and damping rates and other beam and system diagnostics (calibrations, measurements of the system noise floor). Results from the Advanced Light Source and PEP-II are presented to illustrate these techniques.

1 SYSTEM ARCHITECTURE

The architecture of the system has been described in earlier publications [1], [2], [3]. Here we will only emphasize those characteristics of the system that are most important for its diagnostic uses. The system block diagram is shown in Figure 1. There are four main properties of the system that make it a very flexible diagnostic tool. The first is the phase detector that provides a bunch-by-bunch phase measurement. The phase detector is followed by digitizing and processing sections. Processing modules are equipped with local dual-ported memory to allow on the fly data acquisition and offloading. The back-end electronics enables excitation of transient longitudinal motion in the beam synchronized with data acquisition. These functions are tied together with flexible synchronization and triggering electronics.

2 DIAGNOSTICS OVERVIEW

All of the diagnostic techniques developed for use with the digital longitudinal feedback system can be subdivided into two groups: system and beam diagnostics. The former includes methods for hardware and

operational testing and calibration of the system. A variety of timing applications, calibration routines, and built-in error checks make up this group. In the second group we have techniques such as the measurements of growth and damping rates of the unstable and the stable modes, driven motion characterization including spectral analysis and bunch-by-bunch current measurements.

3 SYSTEM DIAGNOSTICS

3.1 Built-in (hardware) diagnostics

The complete feedback system comprises a family of VXI modules, VME modules and dedicated chassis-based electronic functions. There are 80 individual DSP processing elements, plus 5 board-level control computers all configured and controlled from a host network. The system design incorporates numerous levels of software and hardware handshaking to verify the state of the programmable elements. The local processors continuously monitor the state of every DSP using the VxWorks based control software, and every software configuration is checked via a handshake protocol for anomalous conditions during loading and operation. Every DSP transaction with the local interface board is hardware

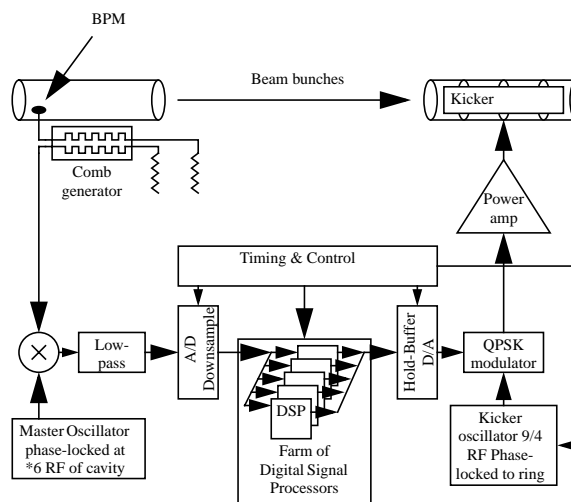

Figure 1. Block diagram of the longitudinal feedback system.

Work supported by Department of Energy contract DE-AC03-76SF00515

Presented at the 3rd European Workshop On Beam Diagnostics And Instrumentation For Particle Accelerators, 12-14 Oct 1997, Frascati, Italy

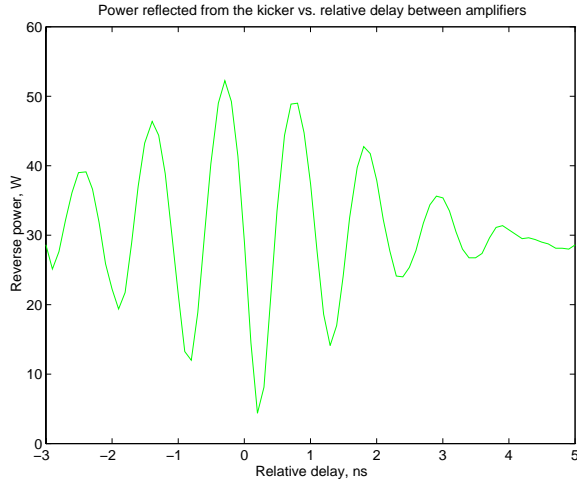

Figure 2. Relative amplifier timing. Relative timing with lowest reflected power is the optimal operating point.

tested for data over-run or under-run conditions (such as might be caused by a halted or inoperative DSP) and every message over the high speed G-Taxi links is checked for protocol or message errors.

The system includes hardware for operation checks without beam in the machine. A “fake beam” generator simulates BPM signals (with synchrotron oscillations) with four bunch spacing. This allows dry-testing of all of the front-end and back-end analog electronics, the digital processing, and the power stages. A set of EPICS-controlled system diagnostics has been created to allow operators to test and certify the proper operation of the system with or without circulating beam

3.2 Software-based diagnostics

A second set of diagnostic measurements is useful for quantifying the system level operation, or the operation of the feedback system interacting with the particle beam. The majority of these measurements use the programmable features of the DSP architecture in conjunction with the dual port memories as a means of recording long sequences of data. Such sequences can be used to quantify the performance of the input phase detector and A/D converter functions (for example, via a histogram test of the A/D converter to test for missing codes, or an RMS noise floor measurement of the detector and A/D circuitry). A suite of DRIVE programs uses the DSP processors to directly excite at a selected frequency a single bunch or group(s) of bunches. Such a technique, in conjunction with a timing code which sweeps delay line settings while measuring the beam motion in the front end, is required to adjust the relative timing of the various amplifiers and kicker structures in the back end. A complete set of DSP and external codes

is used to time-align the front end and back end functions with the circulating particle beam. Figure 2 illustrates the use of the timing diagnostic to verify relative timing of two power amplifiers driving two input ports of the kicker. The goal is to align the kick signals at the kicker input ports, maximizing the voltage seen by the beam. A DSP DRIVE program generates a single-bucket DC kick while a timing program measures amplifier reflected power as a function of relative timing. As the kicker impedance is 25 ohms driven by the two 50 ohm power amplifiers, both amplifiers have to be phased right for the proper match. Thus a point with lowest reflective power gives us relative timing that correctly aligns both kicks. An automated diagnostic allows to consistently achieve optimal timing and to verify it periodically.

4 BEAM DIAGNOSTICS

The time-domain recording techniques developed can be separated into three distinct groups: steady state records, measurements of externally induced transients, and of feedback system induced transients. The first group records steady-state beam behavior, such as noise and driven motion measurements. In the second group are externally triggered data acquisitions, e.g. an injection transient recorder. And finally we have techniques that excite a transient in the longitudinal beam motion through the back-end and record the beam response, such as a grow/damp measurement.

Each DSP is equipped with 16 Kwords of dual-ported memory that is used for data acquisition. Various DSP programs partition this memory in different ways. One

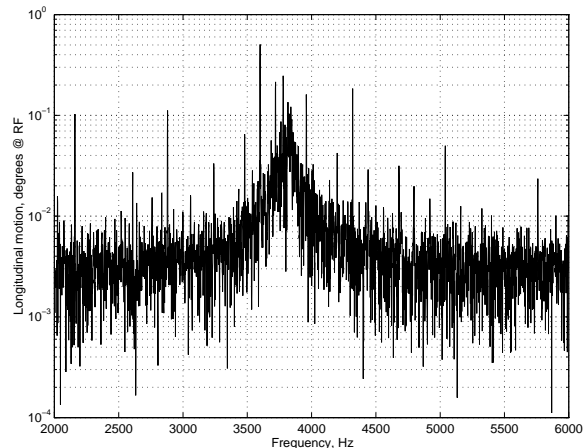

Figure 3. FFT of motion of one bunch recorded in a multibunch fill at PEP-II. This measurements allows to quantify power contained in the line frequency harmonics as well as in the synchrotron mode zero motion excited by the broadband RF noise.

approach is to store the motion of a single selected bunch. For PEP-II that corresponds to a 700 ms long record or 1.4 Hz spectral resolution over an 11 kHz span. Alternatively one can opt to store motion of all bunches in the machine. In case of PEP-II that results in a record length of 29 ms (35 Hz resolution). Due to downsampling the data represents spectral information in 22 kHz bands around each of 1746 revolution harmonics up to 119 MHz. This allows identification and measurement of all possible modes in a single 29 ms snapshot in contrast to slower swept-spectrum measurement.

Figure 3 illustrates the steady-state measurement of a single bunch in PEP-II. The transform of the time data reveals the frequency spectrum used to quantify the driven motion excited by the noise in the RF system.

Free running grow/damp transient measurements have been developed for the measurement of the fastest-growing unstable modes [4], [5]. To measure the growth rates of slower unstable modes or damping rates of the stable modes a driven excitation technique is used [6]. Using a frequency synthesizer we inject excitation at the frequency of the mode to be measured into the summing port before the A/D. The amplitude of the excitation is adjusted to drive the mode above the noise floor while the feedback system maintains control of other unstable modes. When a trigger (hardware or software) arrives the excitation is turned off and motion of all bunches is recorded. Figure 4 presents such a turn by turn FFT of bunch data showing the motion of the excited mode. In the first part of the transient the feedback system is off and the radiation damping determined decay rate can be measured. At 6 ms into the record negative feedback is

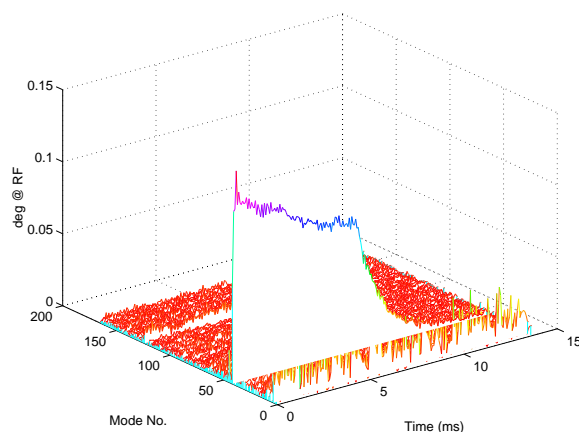

Figure 4. Plot of turn-by-turn FFT of bunch data from ALS. Mode 41 is initially excited by the frequency synthesizer. In the first 6 ms the feedback gain is set to 0 and natural damping rate is observed. Negative feedback gain is restored at 6 ms and produces in a much faster damping rate.

turned on in the DSP program and the oscillations are quickly damped.

5 SUMMARY

The flexibility of the programmable DSP architecture allows system and beam diagnostics to be easily developed and integrated into the feedback system. Most of these techniques use the dual-port memory resources of the DSP boards, either to store an excitation waveform or to record bunch motion during some synchronized transient event. The sequence lengths allow frequency resolutions of 2 - 50 Hz with corresponding spectral spans of 119 MHz in the PEP-II configuration. The flexible software and hardware triggers of the architecture allow measurements to be synchronized to events (such as injection) and allow the functions of the DSP system to be changed on-the-fly. These transient-based beam diagnostics expand on narrowband beam diagnostics with their measurement speed and their applicability to unstable phenomena and transient events.

6 ACKNOWLEDGEMENTS

The authors thank B. Cordova-Grimaldi, J. Hoefflich, J. Olsen, G. Oxoby of SLAC and W. Barry, J. Byrd, J. Corlett, G. Lambertson of LBL for theoretical and technical contributions. Work supported by DOE contract DE-AC03-76SF00515

7 REFERENCES

- [1] G. Oxoby, et al., 'Bunch-by-Bunch Longitudinal Feedback System for PEP-II,' Proc 1994 EPAC, London, England, June 1994.
- [2] A. Young, et al., 'RF and Baseband Signal Processing Functions in the PEP-II/ALS/DAΦNE Longitudinal Feedback System', this conference.
- [3] M. Serio, et al., 'Multi-Bunch Instabilities and Cures' Proc. 1996 EPAC, Barcelona, Spain June 1996.
- [4] J. Fox, et al., 'Observation, Control, and Modal Analysis of Longitudinal Coupled-Bunch Instabilities in the ALS via a Digital Feedback System,' Proc. Beam Instrumentation Workshop, 1996.
- [5] S. Prabhakar, et al., 'Observation and Modal Analysis of Coupled-Bunch Longitudinal Instabilities via a Digital Feedback Control System,' to be published in 'Particle Accelerators'.
- [6] F. Pedersen, et al., 'Theory and performance of the longitudinal active damping system for the CERN PS Booster,' IEEE Trans. on Nucl. Sci., Vol. NS-24, No. 3, June 1977, pp 1396-1398.