

# Simulations of the BNL/SLAC/UCLA 1.6 Cell Emittance Compensated Photocathode RF Gun Low Energy Beam Line\*

D. T. PALMER, R. H. MILLER AND H. WINICK

*Stanford Linear Accelerator Center*

*Stanford University, Stanford CA 94309*

X.J. WANG, K. BATCHELOR, M. WOODLE AND I. BEN-ZVI

*Brookhaven National Laboratory Accelerator Test Facility*

*Upton, NY 11973*

Abstract

A dedicated low energy (2 to 10 MeV) experimental beam line is now under construction at Brookhaven National Laboratories Accelerator Test Facility (BNL/ATF) for photocathode RF gun testing and photoemission experiments. The design of the experimental line, using the 1.6 cell photocathode RF gun developed by the BNL/SLAC/UCLA RF gun collaboration is presented. Detailed beam dynamics simulations were performed for the 1.6 cell RF gun injector using a solenoidal emittance compensation technique. An experimental program for testing the 1.6 cell RF gun is presented. This program includes beam loading caused by dark current, higher order mode field measurements, integrated and slice emittance measurements using a pepper-pot and RF kicker cavity.

## I. Introduction

To produce the high-brightness electron beams needed for short wavelength FEL's [1], a photocathode RF gun with emittance compensation [2] is required. A 1.6 cell photocathode RF gun capable of producing a normalized rms emittance of,  $\epsilon_{n,rms} \approx 1 \pi \text{ mm mrad}$ , has been designed by the BNL/SLAC/UCLA RF gun collaboration to minimize multi-pole modes [3]. Beam dynamics simulations of the gun, with emittance compensation, are presented with and without acceleration. These simulations are used to define the physics requirements of the low energy beam line being built at BNL/ATF. A schematic diagram of the low energy beam line is presented along with the planned program of experimental beam dynamics studies.

## II. Emittance Compensation

In solenoidal magnetic emittance compensated systems, the electron bunch is usually accelerated up to large  $\gamma$  quickly to freeze in the  $\epsilon_{n,rms}$ . The new ATF low-energy experimental beam line employs only an RF gun with no linac to freeze in the  $\epsilon_{n,rms}$  produced by the emittance compensation scheme. We have designed a low energy beam line to measure  $\epsilon_{n,rms}$  over a continuous range of positions downstream of the gun where simulations show the electron bunch attains an emittance minimum,  $\epsilon_{min}$ , for accelerating gradients ranging between 100 – 140 MV/m.

Total Charge	1 nC
Number of particles	10K
Cathode Spot Size	1 mm radius
Longitudinal Profile	Flat Top
Transverse Profile	Flat Top
Initial Cathode KE	.5 eV
Initial Thermal Emittance, $\epsilon_0$	$0 \pi \text{ mm mrad}$
$E_{Full \text{ Cell}}/E_{Half \text{ Cell}}$	1.00
$E_0 \text{ at Cathode}$	100-140 MV/m

Table 1

Electron Bunch Parameters used in Parmela

Parameters from table I were used in PARMELA [4] simulations for section II-A and II-B. Instead of using Fourier coefficients for the RF field calculations in the gun region [5], all simulations for 1.6 cell gun were performed using a field map generated by SUPERFISH. We further improved the magnetic field accuracy of the solenoid magnets by using a field map from POISSON [6]. This improvement was made necessary since each of the two solenoidal magnets, that comprise a bucking pair, is made up of nine 1001 steel laminations with eight current coils sandwiched between them. The magnetic field calculated in parmela using coil cards is accurately represented. All simulations assume both the electron beam and RF fields are cylindrical symmetric. Space charge was included in all parmela simulations. The thermal emittance,  $\epsilon_0$ , was not considered in these simulations. The total emittance  $\epsilon_{n,rms}$  can be expressed as [7],

$$\sqrt{\left(\epsilon_{\text{parmelia}}^2 + \epsilon_0^2 + \epsilon_{mp}^2\right)} \leq \epsilon_{n,rms} \leq (\epsilon_{\text{parmelia}} + \epsilon_0 + \epsilon_{mp})$$

where  $\epsilon_{mp}$  is emittance growth due to the multi-pole fields and  $\epsilon_0$  is the initial transverse emittance of the beam as it is produced off the cathode.

In the following subsections the emittance compensated photocathode RF injector performance with and without accelerating sections are discussed. The former case has application to the proposed RF photocathode gun test stand at SSRL, the DUV-FEL or ATF linac at BNL while the latter case is for the low energy beam line at BNL/ATF.

### A. With Acceleration

As part of the 1.6 cell photocathode RF gun development program a detailed design study of an 1.6 cell RF gun emittance compensated injector was conducted. The starting point for our simulations is the physical layout of the ATF in-line injector.

The parameter space that an in-line RF gun operates in is multi-dimensional. Examples of accelerator section parameters are cathode to input coupler distance, accelerating gradient, and input coupler RF phase. The emittance compensation magnetic parameters are magnet field strength,  $\frac{\partial B_z}{\partial z}$  and the location of  $B_{max}$ . Electron bunch and gun parameters used in these simulations are found in table I. It should be noted that the laser injection phase was set to maximize the electron bunch energy on the output of the gun, which also minimizes the energy spread to 1%. Figure 1 is a plot of  $\epsilon_{n,rms}$  versus  $z$  for an optimized parameter set. A halo is developed around the core of the bunch, in which 2% of the particles contributes 15% of the  $\epsilon_{n,rms}$ .

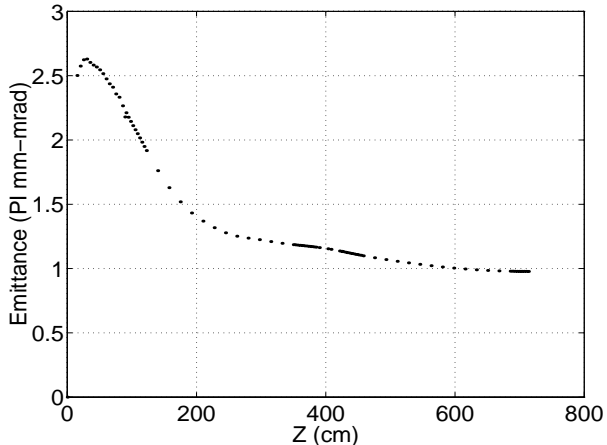

Figure 1. Parmela Simulations of Emittance Compensation with Acceleration

### B. Without Acceleration

The initial testing of the BNL/SLAC/UCLA 1.6 Cell Emittance Compensated Photocathode RF Gun will be conducted on the Low Energy Beam Line at the ATF. Figure 2 is a representative plot of  $\epsilon_{n,rms}$  versus  $z$  for an accelerating gradient of  $100 \text{ MeV/m}$ . An important features that stands out are the two local minima in the emittance. A possible cause of the double local minima is dissimilar space charge forces in the core and tails of the beam. This would cause different slices of the beam to be compensated for at different locations down the beam line. Simulations are on underway to understand this phenomenon.

## III. The ATF Low Energy Experimental Beam Line and Experimental Characterization of the RF Gun

Figure 3 is the schematic diagram of the ATF low energy experimental beam line. The main components of the

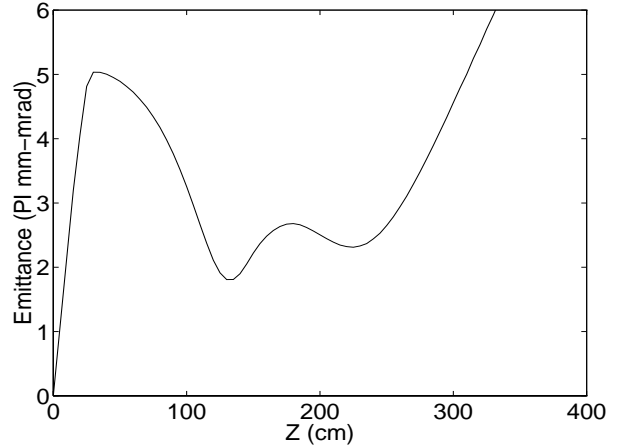

Figure 2. Parmela Simulations of Emittance Compensation without Acceleration

experimental beam line are the 1.6 cell photocathode RF gun and a pair of bucking solenoidal magnets. These are followed by a S-band RF kicker cavity operating at  $\text{TM}_{120}$  mode and a X-axis translational achromate which consist of two  $90^\circ$  sector magnets and a quadrupole triplet.

The nominal operating field for the 1.6 cell RF gun is  $100 \text{ MV/m}$ , therefore a significant amount of field emission current (dark current) will be present. This dark current causes beam loading in the RF gun. The beam loading effect will be experimentally studied using a six-pot reflectometer [8] located in the waveguide feeding the 1.6 cell RF gun.

The diagnostic devices installed on the low energy beam line consists of a RF kicker cavity, energy spectrometer, beam profile monitors and pepper-pots. The pepper-pot located in-line with the gun will be mounted on a  $z$ -translation stage, which will allow the mapping of the integrated  $\epsilon_{n,rms}(z)$ , with a  $z$  range of 100 cm.

When the RF kicker is used in conjunction with the  $z$ -translation pepper-pot, slice emittance studies of the double local minima seen in figure 2 can be conducted. This will allow full reconstruction of the transverse phase space of the beam along the electron bunch. The RF kicker and beam profile monitor will also be used for electron bunch length measurements.

The major improvement of the 1.6 cell gun over the original BNL 1.5 cell gun [9] is the elimination of all field asymmetries in the gun cavity. The manifestation of a field asymmetry is the presence of multi-pole spatial modes in the RF gun. Experimental measurements of the dipole and quadrupole modes will be accomplished by shaping the laser profile on the cathode [10] and observing the transverse electron bunch profile down stream of the gun, as illustrated in figure 4.

The aperture of the 1.6 cell RF gun was increased by 0.5 cm to increase the cell to cell coupling. A secondary benefit is that larger aspect ratio beams can be transported thru the RF gun. Removal of the emittance compensation solenoids and installation of a quadrupole triplet will be ac-

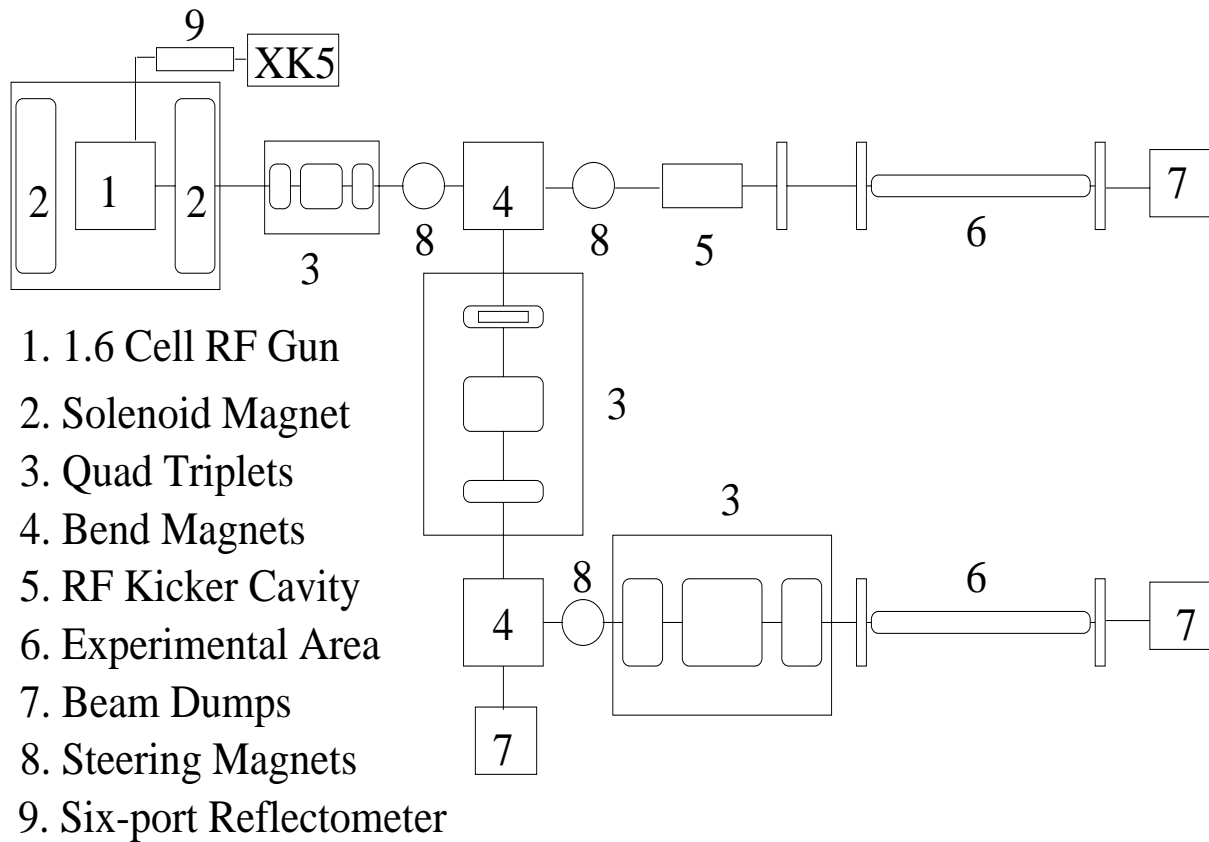

Figure 3. Low Energy Beam Line Design

completed after cylindrical symmetric emittance compensation studies are completed. This will facilitate flat beam experimental studies, which have applications to XLC type RF gun designs [11].

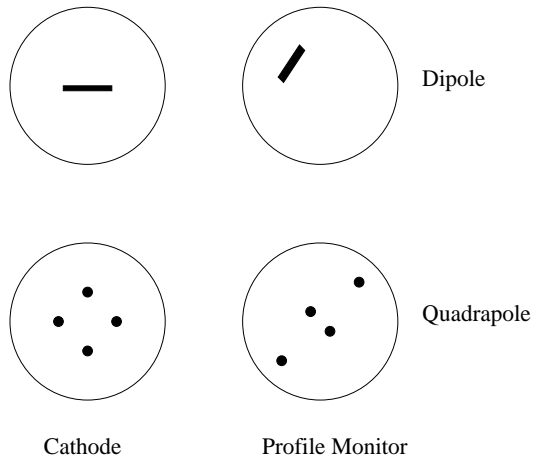

Figure 4. Dipole and Quadrupole Field Effects

#### IV. Conclusions

An emittance compensated photo-injector based on the BNL/SLAC/UCLA 1.6 cell photocathode RF gun is capable of producing  $\epsilon_{n,rms} \approx 1 \pi \text{ mm mrad}$  with a peak current of 100 Amps. We have outlined an experimental

program to test the 1.6 cell RF gun at the ATF low energy experimental beam line. Beam loading will be studied using a six-port reflectometer. Integrated and slice emittance measurements will enable us directly study the emittance compensation process. The  $z$  translation stage pepper-pot will allow mapping of  $\epsilon_{n,rms}(z)$ . Using the kicker cavity in conjunction with the  $z$ -translation pepper-pot will allow for the study of the double local minima in figure 2, which will increase our understanding of the emittance compensation process.

#### References

- [1] H. Winick *et al.*, *NIM*, **A347**, 199-205 (1994)
- [2] B. E. Carlsten, *NIM*, bf A285, 313 (1989)
- [3] D. T. Palmer *et al.*, these proceedings
- [4] L. M. Young, private communications
- [5] J. C. Gallardo and H. Kirk, Proceeding PAC93, 3615-3617 (1993)
- [6] K. Halbach and R. F. Holsinger, *Particle Accelerators*, **7**, 213 (1976)
- [7] K. J. Kim, *NIM*, **A275**, 201-218 (1989)
- [8] C. M. Fortgang *et al.*, *Rev. Sci. Instrum.*, **Vol. 61**, **No. 11**, 3405 (November 1990)
- [9] K. Batchelor *et al.*, Proc. of 1990 EPAC 541 - 543
- [10] Z. Li, private communications
- [11] X. J. Wang *et al.*, RF Gun Studies, CAP-ATF-TECH #11, 1991