

THE LIQUID ARGON CALORIMETER SYSTEM FOR THE SLC LARGE DETECTOR*

G. M. HALLER AND J. D. FOX

Stanford Linear Accelerator Center, Stanford University, Stanford, California 94309

S. R. SMITH

Columbia University, New York, New York 10027

Abstract

In this paper the physical packaging and the logical organization of the Liquid Argon Calorimeter (LAC) electronics system for the Stanford Linear Collider Large Detector (SLD) at SLAC are described. This system processes signals from approximately 44,000 calorimeter towers and is unusual in that most electronic functions are packaged within the detector itself as opposed to an external electronics support rack.

The signal path from the towers in the liquid argon through the vacuum to the outside of the detector is explained. The organization of the control logic, analog electronics, power regulation, analog-to-digital conversion circuits, and fiber optic drivers mounted directly on the detector are described. Redundancy considerations for the electronics and cooling issues are discussed.

1. Introduction

The SLC Large Detector (SLD) is a device for the study of electron-positron collisions in order to gain insight into the fundamental particles and forces of nature [1,2,3]. The SLD measures positions, momenta, energies, and types of the particles produced in electron-positron collisions at energies near the rest energy of the Z^0 particle which will be produced abundantly at the Stanford Linear Collider (SLC). The vertical section of a quadrant of the detector is shown in Fig. 1. The Liquid Argon Calorimeter (LAC) is a sub-system of the SLD which measures energies of particles interacting in its lead-liquid argon active volume. This is accomplished by collecting the ionization produced as particles shower in the radiator structure. In this paper the system which collects and converts the ionization charge into energy and position data is described.

Performance requirements, as well as space and budget constraints, led to a novel design for the SLD LAC electronic system. Input signals are small (less than 16 pC) and must be measured to high precision over a large dynamic range (below 1 fC). The front-end electronics is mounted in "tophats" directly on the cryostat to minimize noise pickup, input capacitance, and cable plant volume and cost. Figure 2 shows the tophats located at the ends of the barrel and on the endcaps. The location of the electronics inside the SLD magnet volume places a premium on reliability, compactness, and low power consumption. The cable plant is kept small through the use of a highly multiplexed control and readout scheme on optical fibers. Only three control fibers and 24 data readout fibers are necessary to service one end of the barrel. In order to minimize heat dissipation problems in the very dense front-end electronics we take advantage of the 120 Hz repetition rate of the SLC, preamplifiers are turned off after each beam crossing. These specialized constraints led us to a solution based on custom chips and hybrids on surface-mount PC boards. The performance of this system is reported in Ref. 4.

2. Description of the Calorimeter

The LAC covers 97% of the solid angle from the interaction point of the colliding beams. It consists of three pieces: the barrel LAC which detects particles leaving the interaction point at large angles to the beam directions, and two endcap LAC's

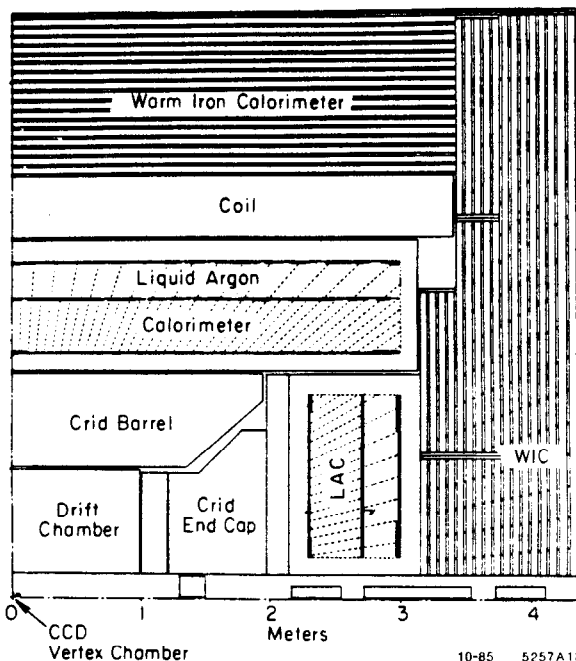

Figure 1. One-quarter cross section of the SLD. The beam axis is along the bottom. The beams collide at the interaction point located in the lower left corner.

which plug the ends of the barrel in order to intercept particles at small angles. Figure 2 shows the detector with the LAC barrel and the endcaps, which are mounted on the doors of the SLD magnet. The barrel and the endcaps are in separate dewars to allow for access to the detector elements surrounded by the LAC while the LAC remains cold.

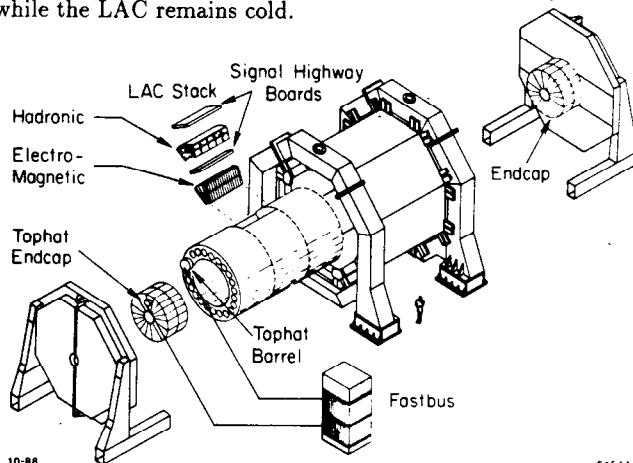

Figure 2. Isometric view of the detector with the LAC barrel and endcaps. The electronics in the tophats is connected to the FASTBUS racks via optical fibers.

*Work supported by the Department of Energy, contract DE-AC03-76SF00515.

An interacting particle incident on the calorimeter showers in alternating layers of lead plates and tiles separated by liquid argon filled gaps. Plates and tiles are 2 mm thick in the front section of the calorimeter where electromagnetic (EM) showers occur. They are 6 mm thick in the back to absorb hadronic (HAD) showers. Argon gaps are 2.75 mm thick everywhere. The ionization charge is swept out of the argon and collected on the lead tiles by a 3 kV DC bias voltage applied between the plates and tiles. Groups of successive tiles along the direction of the incident particle are wired together to form a tower. The segmentation of the calorimeter into towers allows for a position measurement as well as particle identification through the depth of shower development. Segmentation of the calorimeter into towers, and therefore position resolution, is determined by the lateral width of electromagnetic showers. The calorimeter contains a total of 43,776 towers.

The sum of the ionization charge deposited on the tiles of a tower is the basic electrical quantity to be measured. Electrical connection to each tower is made by wiring down the side of the tower from a signal highway board. These 100 cm x 15 cm printed circuit boards are mounted behind each layer of towers (Fig. 2). The highway board provides the 3 kV DC bias voltage for each tower as well as the blocking capacitors which allow the remainder of the signal path to be at low voltage. The highway board gathers the (low voltage) signals onto Teflon™ ribbon cables for a run of up to 2 meters to the end of the dewar where the cryogenic liquid/vacuum feedthroughs are located. Low thermal conductivity wire bundles carry the signals through the insulating vacuum to the room temperature feedthroughs. There are 24 of these vacuum feedthrough flanges on both ends of the barrel calorimeter, each of which carries the signals from 672 towers. Each endcap calorimeter has 24 smaller vacuum flanges carrying up to 192 signal channels.

3. Organization of the Electronics

Tophats are mounted on the liquid argon cryostat. These cylindrical enclosures provide mechanical and electrical protection for the front-end electronics. Each tophat measures 41 cm in diameter and 13 cm in height. Tophats are mounted directly

over the vacuum feedthrough flanges which hold the hermetic feedthroughs carrying calorimeter signals out of the insulating vacuum. A printed circuit mother board, mounted over the flange, provides mechanical support and electrical interconnections for six types of active printed circuit boards enclosed in the tophat. This mother board has a shape of a ring with an outer diameter of 40 cm with a 25 cm x 20 cm hole in the center.

The analog processing of detector signals is performed on fifteen 48-channel "daughter boards" in each tophat [5]. These 13 cm x 18 cm printed circuit boards plug into the mother board and, through the hole in the center of the mother board, directly into the 50-pin hermetic signal feedthroughs on the vacuum flanges. Daughter boards contain low noise, charge sensitive preamplifiers with unipolar shaping, dual gain stages, and analog memories which store separate baseline and peak signal amplitudes for each gain [5]. The daughter board has a full scale range of 16 pC with an equivalent input noise charge of less than 5,000 electrons at a shaping time of 4 μsec with 1 nF input capacitance. One daughter board handles 48 detector channels and is populated with the following custom hybrid devices: three 16-channel input protection hybrids, six 8-channel preamplifier and calibration hybrids, and three 16-channel analog storage and multiplexing HCDU hybrids [5,6]. The HCDU contains a custom integrated circuit, the Calorimeter Data Unit (CDU), implemented in NMOS technology [7].

The other types of boards in the tophat are an A/D board, a controller board, a low voltage power supply board, a high voltage filter board, and a cryogenics monitoring board. The A/D board holds analog-to-digital converters and optical fiber transmitters to digitize and transmit the signals from the daughter boards. The controller board receives, interprets, and distributes control and timing information for the tophat. The power supply voltages for the electronics are filtered and regulated on the low voltage power supply board. The high voltage required to drift ionized particles in the calorimeter towers is filtered by the HV-filter board at the vacuum feedthrough. The cryogenics board monitors tophat and cryostat functions such as temperatures and liquid levels in the argon, and supply voltages and temperatures on the tophat. This board [8] includes

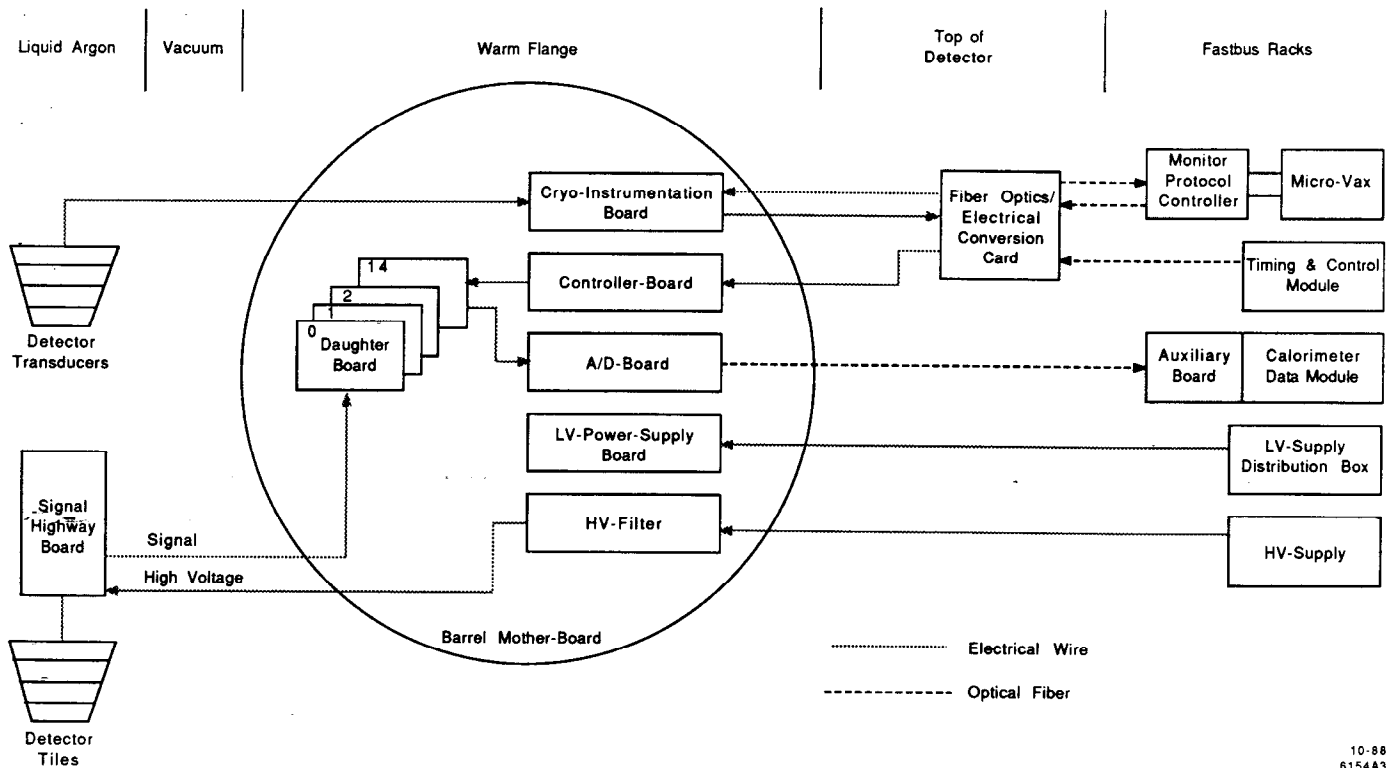

Figure 3. Signal and control flowchart of the LAC electronics.

a microprocessor which exchanges data with a MICRO-VAX under an RS-422 protocol. Figure 3 illustrates the signal and control flow from the detector tiles to the FASTBUS data processing system. Figure 4 shows a view of a barrel mother board with the above boards plugged in.

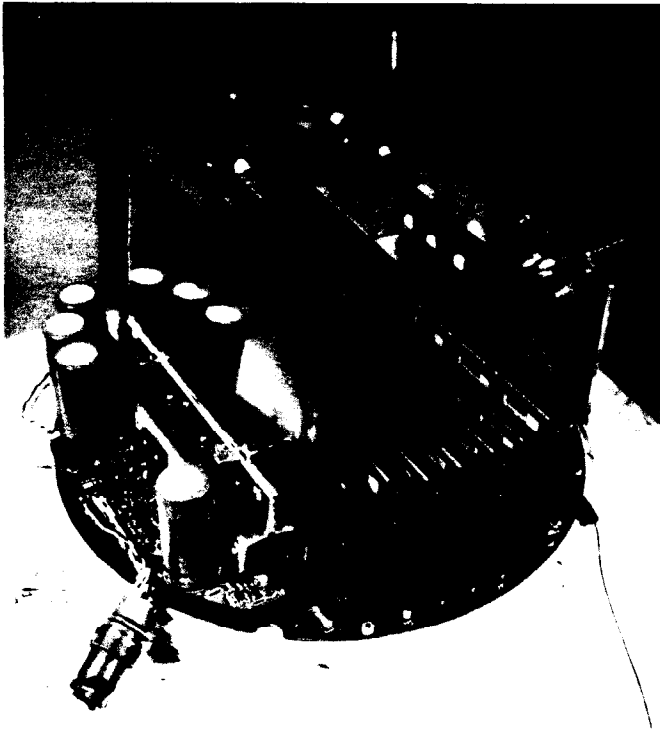

Figure 4. Tophat mother board with the controller, A/D, power supply, and 15 daughter boards plugged in.

Since the endcap vacuum flanges are too small to carry the signal processing and control boards, two types of endcap mother boards have been designed. Type B carries four daughter boards (192 channels). Type A holds the controller, A/D, and cryo-instrumentation boards. Three type B and one type A mother boards are interconnected by flat cable to form a set similar to a barrel tophat.

4. Signal Flow

Figure 5 shows the signal flow from the tiles of a calorimeter tower to the FASTBUS processing modules. The charge generated by a particle ionizing the argon in a calorimeter tower is amplified and stored in analog form on daughter boards. A baseline and peak signal are stored for each of two gain levels for each tower. The stored voltages are multiplexed onto the daughter boards' differential analog output which connects via the mother board to the A/D conversion board. The A/D board is organized in eight processing channels, each serving two daughter boards. The differential current from a daughter board is converted to a single ended voltage, sampled, and digitized by 3.2 μ sec low power CMOS A/D converters. A parity bit and three framing bits are added to the 12 bit conversion result to detect data transmission failures. The eight 16 bit data words from one conversion cycle are loaded in a chain of parallel/serial shift registers which are clocked at a rate of 32 MHz. The serial bit stream is converted to an optical signal and sent on 15 m long fibers to FASTBUS racks on top of the detector.

The calorimeter data is to be used as part of the detector trigger system, therefore the digitized data in all tophats must be read out every beam crossing. The repetition rate of the SLC facility is expected to be 120 Hz, while the time to transmit the 3072 data words from one tophat is approximately 1.5 ms. For this reason all 16 endcap type A and all 48 barrel tophats are read out simultaneously, each tophat having its' own 32 MHz serial fiber optic link.

In the FASTBUS racks the data is processed in auxiliary cards and Calorimeter Data Modules (CDM) [9]. The optical signal from the tophats is converted to an electrical signal, deserialized, and temporarily stored in random access memory. The data words are then piped to a custom integrated circuit on the CDM, the Data Correction Unit (DCU) [10]. This device performs a 16 segment piece-wise linear correction to the data to correct for (small) nonlinearities in the analog signal processing. Parameters for the linear interpolation are acquired in calibration runs taken several times a day. The DCU also performs baseline subtraction and gain selection for the dual range scheme as described in Refs. 5, 9, and 10. The corrected data is then processed by a digital signal processor channel on the CDM module based on the Motorola 68020 microprocessor. This corrected data is passed via the FASTBUS system to an AEB (Aleph Event Builder) module [11] which is utilized for trigger decisions and the first level of online data processing. The processed data is transmitted via the FASTBUS system for offline storage and processing.

5. Control Flow and Redundant Design Philosophy

The electronics of the LAC signal processing system is controlled from a FASTBUS Timing and Control Module (TCM [12]) as shown in Fig. 3. This master timing source is used throughout the SLD detector and provides a means to synchronize detector components to the SLD master clock. The LAC barrel and endcap systems are controlled from a single TCM module. This module uses a three signal serial protocol to transmit commands, data, and timing information to the controller logic resident in each tophat. This protocol provides a general purpose structure to operate, calibrate, digitize, and read out the analog signal paths from the calorimeter towers.

A typical event readout sequence is implemented in sequential logic synchronized to the timing information sent by the TCM module: Such a sequence begins with powering up the analog circuitry, providing baseline and signal peak strobe commands for the HCDU sample and hold circuits, powering down the preamps, sequentially digitizing the 3072 analog values, and serially shifting out the digital data over a 32 MHz digital fiber optic link. Command sequences are also provided for calibration and diagnostic functions. The logic functions are implemented in Altera EP610 CMOS programmable gate arrays and CMOS support logic. The controller also contains digital-to-analog converters used as part of a preamplifier calibration system and drive circuitry used to distribute control and calibration signals to all 15 daughter boards within a tophat.

The relative inaccessibility of the LAC signal processing electronics strongly influenced the architecture of the system. As most of the electronic components are physically inside the magnet and shielding structure of the detector, access for maintenance may not be possible without several days of downtime. The resulting need for reliability has suggested a design approach which attempts redundancy in critical components and eliminates single point failures which could disable major portions of the detector. This redundancy begins with two independent fiber optic control paths that distribute the three TCM control and timing signals to the tophats. The controllers in each tophat are functionally redundant as each is composed of two identical sets of logic arrays, either of which can be enabled or disabled from either of the two control paths. Dual calibration and control circuits are also implemented, and the output serial data is sent out over duplicate fiber optic links. The local power supplies in each tophat are composed of five independent supplies, so that a single component failure in a voltage regulator or on a processing board disables only a portion of a tophat.

6. Low Voltage Distribution

The low voltage for the tophats is supplied by distribution boxes located in supply racks on the detector. Each distribution box serves eight tophats and contains three switching power supplies and monitoring circuitry for current and voltage levels. Twenty meters of twisted pairs 16 gauge cable connect the supplies to the LV-power supply boards in the tophats. These boards contain remotely resettable fuses, energy storage capac-

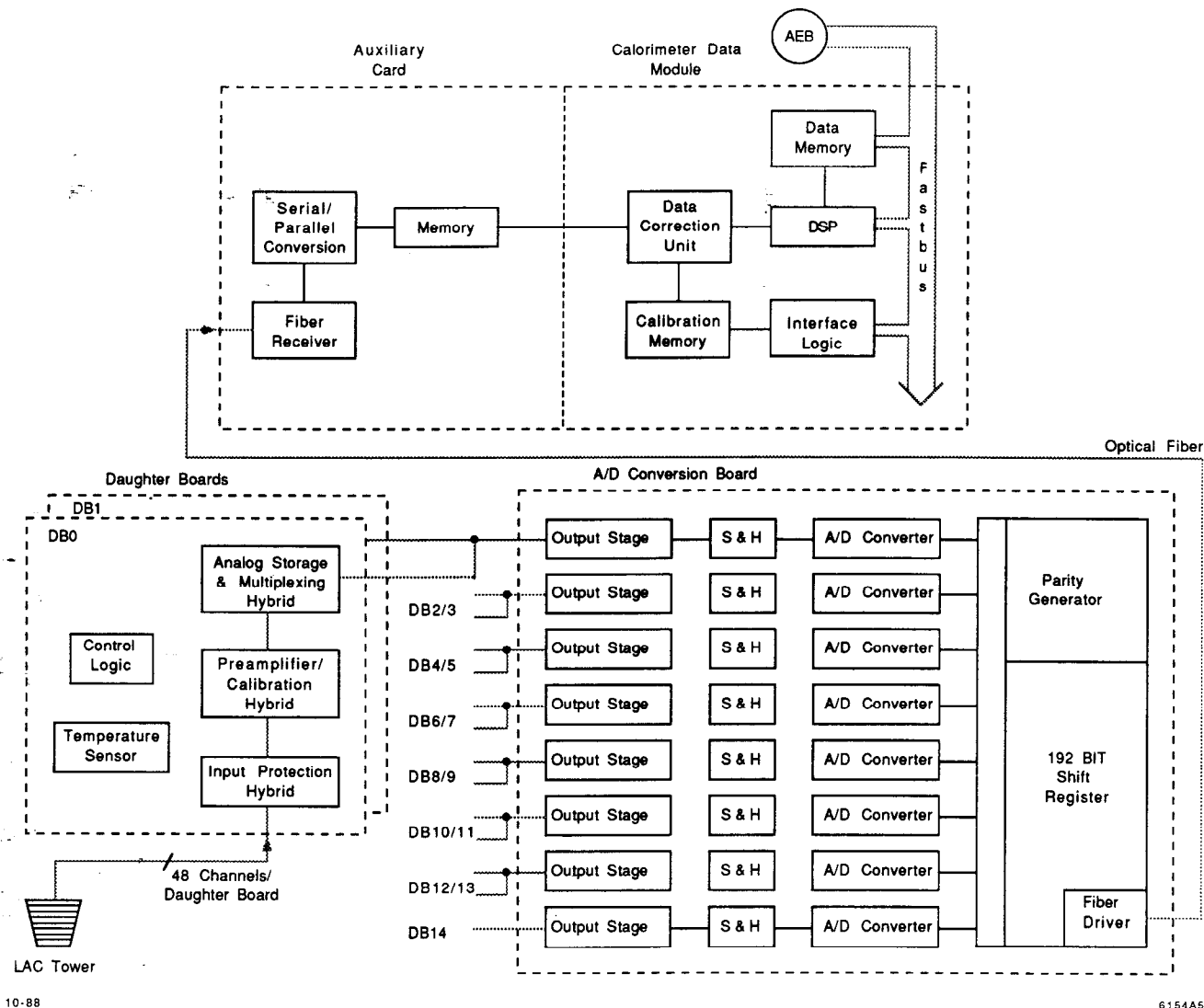

Figure 5. Signal flow from the detector tiles to the FASTBUS system.

itors, and voltage regulators. The preamplifiers on the daughter boards require 650 mW per channel, which leads to a heat dissipation problem. The preamplifiers are therefore turned off between beam crossings. They are powered on 1 ms before the next beam crossing to stabilize and remain on for a maximum of 100 μ sec for cosmic data taking. The duty factor is therefore approximately 13% and the power consumption of a whole tophat is 61 W. The electrical energy is stored locally on 16,000 μ F capacitors, which also reduces the required current capacity of the power supplies and cables. The power is distributed in five groups for each tophat to avoid the loss of a full tophat of electronics due to a failure on one of the processing boards. The voltages are then regulated to their final values by low voltage drop regulators.

The tophat itself acts as a heat sink to conduct the heat from the regulators to water pipes surrounding the hat. The heat generated by the preamplifiers mounted on the daughter boards is convected to aluminum fins located between the daughter boards. These fins are welded to the outer cylinder of the hat and also provide electrical shielding. The temperature gradient from the waterpipes (13 degree Celsius) to the surface of the preamplifiers is about 17 degree Celsius. Figure 6 shows the mechanical package for the tophat electronics.

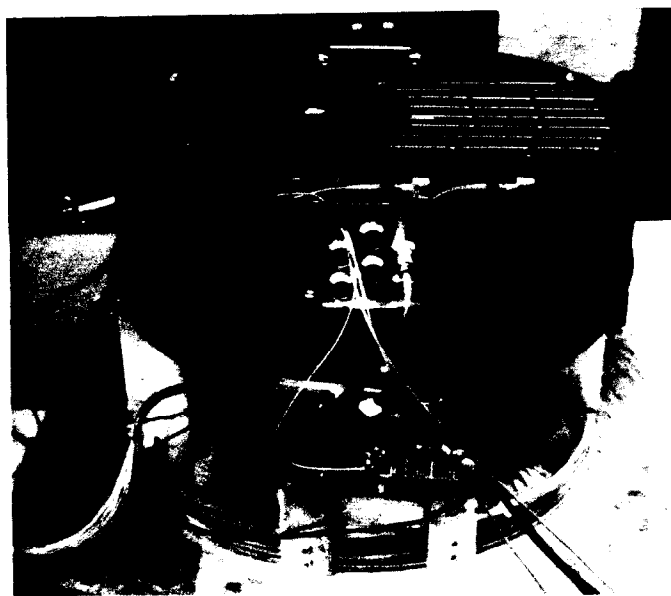

Figure 6. Tophat enclosures provide mechanical and electrical protection for the electronics. The heat is conducted to a waterpipe surrounding the hat.

7. Project Status

As of October 1988 all 288 barrel calorimeter modules have been installed in the barrel cryostat. This assembly is ready for final installation in the SLD detector at SLAC. One of the two endcaps is completely loaded with its modules. System tests have been completed for all portions of the LAC signal processing components and all custom electronic hybrids and circuit board assemblies are in production. Final electronic installation and checkout of the LAC system is planned for winter 1989 with full cooldown and commissioning of the system by spring 1989.

Acknowledgments

The authors gratefully acknowledge M. Breidenbach and L. Paffrath for their conceptual contributions and support. Special thanks to D. Nelson for the conceptual design of the LAC electronics system and for his original reliability analysis. Thanks are also due to A. Gioumouzis for the detailed design of the daughter boards and of the controller card. The authors also acknowledge P. Seward for the design of the signal routing and mother board assemblies.

References

- [1] *SLD Design Report*, SLAC-273, UC-34D (T/E/A).
- [2] R. S. Larsen, *Overview of the Data Acquisition Electronics System Design for the SLAC Linear Collider Detector (SLD)*, IEEE Trans. Nucl. Sci. **NS-33**, 65 (1986).
- [3] M. Breidenbach, *A Status Report on the SLD Data Acquisition System*, presented at this conference.
- [4] E. Vellà, I. Abt, G. M. Haller and A. Honma, *Performance of the Electronics System for the Liquid Argon Calorimeter of the SLD Experiment at the SLC*, presented at this conference.
- [5] G. M. Haller, D. Nelson and D. R. Freytag, *The Analog Processing System for the Liquid Argon Calorimeter for SLD at SLAC*, IEEE Trans. Nucl. Sci. **NS-34**, 170 (1987).
- [6] G. M. Haller, J. Moss, D. R. Freytag, D. Nelson, A. Yim and C. Lo, *Design and Fabrication of Advanced Hybrid Circuits for High Energy Physics*, IEEE Trans. Nucl. Sci. **NS-35**, 217 (1988).
- [7] G. M. Haller, D. R. Freytag, J. T. Walker and S. I. Chae, *Performance Report for Stanford/SLAC Multi-Channel Sample-and-Hold Device*, IEEE Trans. Nucl. Sci. **NS-33**, 221 (1986).
- [8] M. Fox and J. Fox, *A Cryogenic Monitor System for the Liquid Argon Calorimeter in the SLD Detector*, presented at this conference.
- [9] L. Paffrath et al., *A General Purpose FASTBUS Data Acquisition Slave Module for SLD*, presented at this conference.
- [10] S. MacKenzie et al., *The Data Correction Unit—A Data Correction/Compaction Chip*, IEEE Trans. Nucl. Sci. **NS-34**, 250 (1987).
- [11] A. Marchioro et al., *The Aleph Event Builder*, IEEE Trans. Nucl. Sci. **NS-34**, 133 (1987).
- [12] J. Hoefflich, University of Illinois, internal SLD document.