

RESEARCH AT SLAC ON FUTURE LINEAR COLLIDERS*

P. B. Wilson

Stanford Linear Accelerator Center
Stanford University, Stanford, California 94305

1. INTRODUCTION

Research at SLAC on a linear collider beyond the SLC is directed toward a machine with a center-of-mass energy on the order of 1 TeV, which would fit on a SLAC-Stanford site and which could be built by the mid-1990's using essentially present-day technology. The maximum straight-line length available on a Stanford site is a little over 7 km. About 25% of this length must be reserved for a final focus region, for linac focussing elements, and to take account of the fact that the bunches will be off the crest of the accelerating wave. The gradient required in the accelerating structure itself must therefore be about 185 MV/m.

Two committees appointed by SLAC director Burton Richter are currently looking at the particle physics and accelerator technology issues associated with such a collider. A preliminary recommendation by the physics committee, chaired by M. Peskin, is that a luminosity of $10^{33} \text{ cm}^{-2} \text{ s}^{-1}$ is required if the machine is to produce "interesting" physics, while a luminosity of $10^{34} \text{ cm}^{-2} \text{ s}^{-1}$ is desirable for "detailed" physics. A design would be acceptable that could confidently reach $10^{33} \text{ cm}^{-2} \text{ s}^{-1}$ in a reasonable time after turn-on, with the capability of later being upgraded to $10^{34} \text{ cm}^{-2} \text{ s}^{-1}$. A beamstrahlung energy loss on the order of 0.3 is felt to be acceptable.

The accelerator committee, chaired by J. M. Paterson, feels that the energy and gradient can be attained with some modest extensions of presently existing technology. On the other hand, assuming 100 MW of wall plug power for the RF system, a luminosity of $10^{33} \text{ cm}^{-2} \text{ s}^{-1}$ is only just obtainable on paper, with no allowance for any emittance degradation in the damping rings, linac or final focus. A luminosity of $10^{34} \text{ cm}^{-2} \text{ s}^{-1}$ will require either much higher wall plug power or new concepts.

A conceptual diagram of a linear collider is shown in Fig. 1. An electron gun supplies single bunches or a train of bunches to an injector linac, which accelerates the bunches to about 1 GeV for injection into a damping ring. The bunches emerge from the damping ring with a bunch length on the order of 1 cm and a relative energy spread on the order of 10^{-3} . The bunches are rotated in phase space to reduce the bunch length to $\approx 1 \text{ mm}$, while the energy spread is increased to $\approx 10^{-2}$. The bunches are then accelerated to $\approx 10 \text{ GeV}$, where a second bunch rotation takes place. Both the injector linac and the preaccelerator will probably operate at a lower frequency than the main linac to reduce wakefield effects at low energies. Advances in low emittance photocathode guns may make it possible to

*Work supported by the Department of Energy, contract DE-AC03-76SF00515.

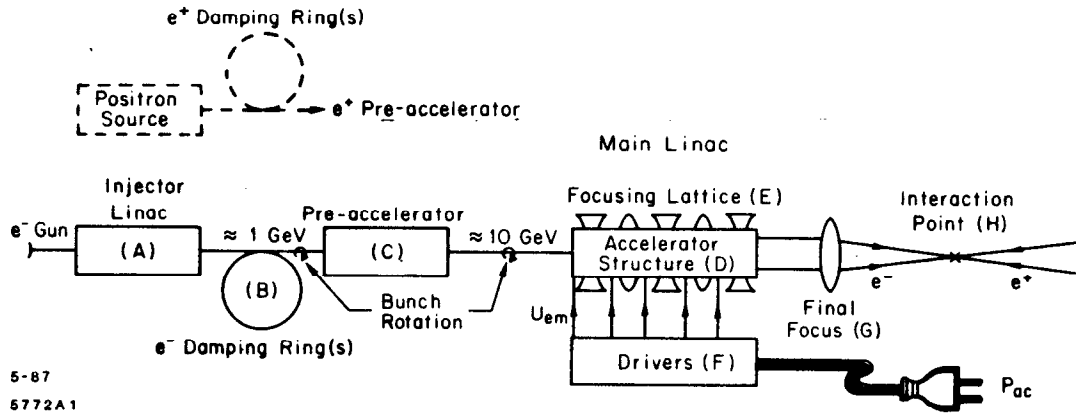

Fig. 1. Conceptual diagram of a linear collider.

eliminate the electron damping ring. However, the positrons bunches will almost certainly need to be damped after production. Although exotic positron sources have been proposed, the most likely source remains a high current electron beam accelerated by a (relatively) low energy linac, a conversion target, and a second linac to capture and accelerate the positrons to the damping ring energy.

A number of exotic concepts have been proposed for the main accelerator-driver combination shown in Fig. 1; for example, a plasma driven by a laser or electron beam, or an array of concentric metallic disks driven by a ring bunch (wakefield transformer). A survey of advanced accelerator concepts is given in Ref. [1]. However, the main linac for a linear collider that is to be operational in the mid-1990's will almost certainly be a periodic metallic accelerating structure driven by high power pulsed RF in the 10-30 GHz frequency range. A brief survey of current thinking at SLAC concerning the design of such a collider is given in the following sections.

2. GENERAL COLLIDER PARAMETERS

It is well-known that the "beamstrahlung" emitted by colliding bunches is a function of a scaling parameter $\bar{\Upsilon}$, where $\bar{\Upsilon} \lesssim 0.2$ denotes the so-called classical regime, $0.2 \lesssim \bar{\Upsilon} \lesssim 100$ the transition regime, and $\bar{\Upsilon} \gtrsim 100$ the quantum regime. For a collider with $E_{c.m.} \approx 1$ TeV, a luminosity $\mathcal{L} \approx 10^{33} \text{ cm}^{-2} \text{ s}^{-1}$, and having also a reasonable bunch length and total AC "wall plug" power for a room temperature RF system, it can be shown [2] that the parameter $\bar{\Upsilon}$ lies in the transition regime. For this case the fractional energy loss to beamstrahlung is roughly

$$\delta \approx 5 \left[\frac{\mathcal{L} (10^{33})}{f_b (\text{Hz})} \right]^{1/2} \left[\frac{2R^{1/2}}{1+R} \right] \quad (1)$$

Here $\mathcal{L}(10^{33})$ is the luminosity in units of 10^{-2} s^{-1} , f_b is the bunch collision rate, and $R = \sigma_x^*/\sigma_y^*$ is the ratio of the transverse bunch dimensions at the collision point. For $\mathcal{L} = 10^{33} \text{ cm}^{-2} \text{ s}^{-1}$ and $\delta = 0.3$, we have

$$f_b \approx 3 \times 10^3 \quad , \quad R = 1 \quad (2a)$$

$$Rf_b \approx 1 \times 10^4 \quad , \quad R \gg 1 \quad (2b)$$

Thus either a high collision rate or a large aspect ratio is required to keep the beamstrahlung to a tolerable level.

For a conventional disk-loaded copper accelerating structure (group velocity $v_g/c \approx 0.05$), the peak RF power per meter and the total AC wall plug power are given roughly by

$$\hat{P} \text{ (MW/m)} \approx .015 [G \text{ (MV/m)}]^2 [\lambda \text{ (cm)}]^{1/2} \quad , \quad (3a)$$

$$\bar{P}_{ac} \text{ (MW)} \approx 6 \times 10^{-4} f_r \text{ (Hz)} G \text{ (MV/m)} E_0 \text{ (TeV)} [\lambda \text{ (cm)}]^2 \quad . \quad (3b)$$

Equation (3b) assumes an RF system efficiency of 40%. Here G is the accelerating gradient, λ the RF wavelength and f_r the RF repetition rate. It is related to the bunch collision rate by $f_b = bf_r$, when b is the number of bunches accelerated per RF pulse.

Using Eqs. (2) and (3b) for $G = 185$ MV/m, $E_0 = 2 \times 0.5$ TeV and (for example) $\lambda = 2.6$ cm at 11.4 GHz, we see that $\bar{P}_{ac} \approx 2$ GW for a round bunch and $\bar{P}_{ac} \approx 80$ MW for $R = 100$ and $f_r = 100$ Hz. Thus we are forced to collide bunches with a large aspect ratio to obtain a reasonable beamstrahlung parameter for a reasonable wall plug power, assuming a room temperature RF system with a wavelength of 2 or 3 cm.

To complete the list of collider beam parameters, we must fix the number of particles per bunch, N , the transverse bunch area $A = \sigma_x^* \sigma_y^* = R\sigma_y^{*2}$, and the bunch length σ_z . Disruption provides a constraint on the possible choices for these parameters. By eliminating the bunch area using the standard expressions for the luminosity and the disruption parameter D , we obtain

$$\frac{\sigma_z \text{ mm}}{N (10^{10})} = 5.6 \times 10^{-4} \frac{f_b \text{ (Hz)} E_0 \text{ (TeV)} DH_D}{\mathcal{L} (10^{32})} \left[\frac{1+R}{2R} \right] \quad . \quad (4a)$$

Here H_D is the luminosity enhancement factor due to pinch. For stable bunch collisions, the product DH_D should not exceed about 30 for flat beam collisions ($D \approx 12$, $H_D \approx \sqrt{6}$). Using also $\mathcal{L} = 10^{33} \text{ cm}^{-2} \text{ s}^{-1}$, $E_0 = 0.5$ TeV, and the constraint $f_b = f_r \approx 100$ set previously by beamstrahlung and AC power considerations, we obtain

$$\frac{\sigma_z \text{ (mm)}}{N (10^{10})} \lesssim 0.04 \quad . \quad (4b)$$

In the following sections we will find that constraints imposed by the damping rings, final focus and beam loading energy spread will confine N to the order of 1×10^{10} , give or take a factor of three depending on the RF wavelength. Thus we have been forced into a region of parameter space where the bunch length is rather short, in the range of 10–100 microns.

3. COLLIDER SYSTEMS

A brief discussion of on work at SLAC on the various collider systems is presented in the following sections.

3.1 ACCELERATING STRUCTURES

RF breakdown measurements in a disk loaded accelerating structure at several frequencies have been reported by Loew and Wang [3]. The peak surface field at breakdown at 2.85 GHz is about 310 MV/m (corresponding to an accelerating gradient of ≈ 140 MV/m in the SLAC structure) for a pulse length T_p of one or two microseconds. The breakdown field scales with frequency as $\omega^{1/2}$ at a fixed pulse length. Other measurements [4] at SLAC as a function of pulse length at a fixed frequency indicate that the breakdown field varies approximately as $T_p^{-1/4}$ for pulse lengths less than a few microseconds. However, intense field emission even below breakdown may limit the gradient to somewhat lower values.

Extensive calculations of the properties of the standard disk loaded structure as a function of group velocity at a given frequency have been made by Z. D. Farkas [5]. The calculated parameters include: the disk aperture, the ratio of peak surface field to average accelerating gradient, the elastance (defined as G^2/u , where u is the stored energy per unit length), and the attenuation time $T_0 = 2Q/\omega$. The properties of several "exotic" accelerating structures are also currently being investigated [6]. One such structure, the undulating waveguide, has the potential for greatly reduced longitudinal and transverse wakefields compared to a disk loaded structure. Such a structure could be useful not only for the main accelerator but also for a damping ring RF cavity, so as to reduce the ring impedance to an absolute minimum. The elastance for the undulating waveguide structure is about one-half that for a disk-loaded structure with $v_g/c = 0.05$.

R. Palmer [7] is currently investigating disk loaded structures with an elliptical cross-section. Such structures would have reduced wakefields in one transverse direction and would be ideal for the acceleration of flat beams, where only the wakefield in the narrow beam dimension is important. Structures with slots for damping transverse deflecting modes, which would allow the acceleration of multiple bunches per RF fill, are also being investigated [7].

3.2 RF POWER SOURCES

From Eq. (3a) we see that the peak power per meter required by a linac operating at $G = 185$ MV varies from 500 to 1000 MW/m in the wavelength range 1 to 3 cm. The filling times for practical structures would be 20–100 ns for this same wavelength range. These short, high-power RF pulses can be generated in several ways. In the first method, a longer RF pulse ($\approx 1 \mu\text{s}$) is generated by more or less conventional microwave tubes with an output power on the order of 30 MW ($\lambda = 1$ cm) to 150 MW ($\lambda = 3$ cm). Using the RF pulsed compression technique described by Z. D. Farkas [8], the pulse length can be reduced and the peak power enhanced by a factor of 2^n , where n is an integer. Several possibilities, for example gyrokystrons and sheetbeam klystrons, have been suggested as microwave power sources at the above power levels. Conventional round-beam klystrons at a wavelength $\lambda \lesssim 3$ cm look very difficult to build at this power level (e.g., 150 MW at $\lambda = 3$ cm). However, a gyrokystron which will produce about 30 MW at $\lambda = 3$ cm is nearly operational at the University of Maryland [9]. The device is said to be scaleable by a factor of ten in power to ≈ 300 MW at this wavelength.

A second way to generate high power pulses of RF at short wavelengths is by means of a two-beam accelerator, such as the CLIC accelerator [10] proposed by CERN. In this scheme a low-energy high-current beam accelerated by low-frequency superconducting cavities runs parallel to the main accelerator. The beam is bunched at the operating frequency of the main linac. Transfer cavities periodically extract RF energy from this driving beam at a pulse length equal to the filling time of the main accelerating structure.

At SLAC a third RF power generation method is being considered, which is in a sense a hybrid between a conventional microwave tube and a two-beam accelerator. A klystron-type sequence of bunching and RF output cavities is driven by a high-current (≈ 1 kA) beam with an energy of several MeV. Beams with these parameters are routinely attained at Lawrence Livermore National Laboratory (LLNL) using induction linac technology. A collaboration between SLAC and LLNL is currently in progress to exploit this technology to develop an RF power source appropriate for a high-gradient linear collider. In a prototype experiment [11], such a "relativistic klystron" has recently produced about 75 MW at 8.6 GHz in a 30 ns pulse, with good efficiency ($\approx 50\%$). Work is in progress on an 11.4 GHz device with sufficient output power to test a section of disk loaded accelerating structure at high gradient. The ARC test facility at LLNL is capable of producing high-voltage (≈ 4 MV) beams with a power up to about 10 GW. Future experiments will exploit this capability to produce a relativistic klystron with several output cavities giving a total RF output power on the order of 5 GW. Such a device could power a 5 m linac module to about 1 GeV.

3.3 DAMPING RINGS

The design of a continuous wiggler type of damping ring for flat beams is described by R. Palmer [12]. It is assumed that the coupling in such a ring can be reduced sufficiently to allow a vertical to horizontal emittance ratio of 1%. The minimum emittance is obtained for a ring with an energy of about 1 GeV, such that the contributions to the emittance from quantum fluctuations and intrabeam scattering are comparable. The allowable bunch current is also limited by bunch lengthening, which in turn is determined by the ring impedance. Taking these and other factors into account, Palmer concludes that normalized vertical and horizontal emittances of 3×10^{-8} m and 3×10^{-6} m, respectively, can be attained for bunches with 1 to 2×10^{10} particles. The longitudinal emittance for these parameters is appropriate for a linac operating at a wavelength in the range 1.5 to 2.5 cm.

3.4 FINAL FOCUS

We assume flat beams colliding at a slight angle at the interaction point. The design of a final focus beam system for flat beams has been investigated by R. Palmer [12]. The minimum vertical (narrow) beam dimension that can be obtained in this design is

$$\sigma_y^* \approx \left[\frac{C \epsilon_{ny}^2 \left(\frac{\sigma_p}{p} \right)^2}{\gamma B_p} \right]^{1/3}, \quad (5)$$

where σ_p/p is the relative momentum spread, B_p is the maximum quadrupole pole tip field ($B_p \approx 1.4$ T), and $C = 1.1 \text{ T}^{-\text{m}}$ is a constant. Because of the natural asymmetry of the quadrupole final focus system, the horizontal beam size in Palmer's design is given by

$$\frac{\sigma_x^*}{\sigma_y^*} = 1.8 \frac{\epsilon_{nx}}{\epsilon_{ny}} = 180 \quad . \quad (6)$$

As the energy spread is reduced, Eq. (5) will eventually fail because tolerance requirements will become excessive. Palmer takes a lower bound to be $\sigma_p/p \approx 0.15\%$. Recent studies, however, indicate that the scaling given by Eq. (5) may be optimistic [7]. Further work is needed to determine the constant C and the dependence on σ_p/p for a practical flat beam final focus system.

3.6 LINAC BEAM DYNAMICS

From Eq. (5) we see that the luminosity will be degraded if the energy spread in the bunches from the linac is too large, or if the emittance delivered by the damping rings is allowed to grow in the linac. The energy spread at the end of the linac is determined by the curvature of the RF wave, by the longitudinal wake potential, and by the initial energy spread delivered by the damping ring. In turn, the energy spread from the longitudinal wake potential can be minimized by running the bunch at the proper phase off the crest of the accelerating wave. The minimum relative energy spread that can be attained is a function of σ_z/λ and the energy extraction efficiency per bunch, given for a typical disk loaded structure by

$$\eta_b \approx 10 \frac{N (10^{10})}{G (\text{MV/m}) [\lambda (\text{cm})]^2} \quad . \quad (7)$$

For bunches of the proper length (short but not too short), the minimum energy spread is given by $\sigma_p/p \approx 0.1 \eta_b$. Thus for an energy spread on the order of 0.15%, η_b is limited to about 1.5%. For $G = 185$ MV/m, Eq. (7) then gives $N \approx 0.3-3 \times 10^{10}$ for λ in the range 1 to 3 cm.

Several effects can cause the transverse emittance to increase during acceleration in the main linac. Transverse single bunch wakefield effects can be ameliorated by Landau damping. To produce Landau damping, an additional energy spread is introduced between the head and tail of the bunch by changing the off-crest phase angle by an appropriate amount. This energy spread must be eliminated before the final focus by an additional (relatively short) length of linac operating with the bunch at a zero crossing of the RF wave. The length of this compensation linac is proportional to the bunch extraction efficiency η_b , which is another reason why η_b should not be too large. Jitter in the position of the linac focussing quadrupoles due to ground motion can also cause an increase in emittance. However, pulse-to-pulse feedback can control the effect of the low-frequency component of the ground motion. The high frequency component of the motion is well within the allowable tolerance for typical collider parameters [12].

The problem of emittance preservation in a linear collider has been treated recently by R. Ruth [13]. In addition to the wakefield and quadrupole jitter effects mentioned above, Ruth also considers the tolerances imposed by injection jitter, by jitter due to transverse kicks in misaligned accelerating sections, by chromatic effects in the linac, and by coupling due to random quadrupole rotation errors. Using the collider parameters summarized in

the next section, a general conclusion is that the required tolerances, while in some cases rather tight, are not unreasonable.

4. A CONSISTENT SET OF COLLIDER PARAMETERS

In the preceding sections we have seen that the parameters of a linear collider with a center-of-mass energy of 1 TeV and a luminosity of $10^{33} \text{ cm}^{-2} \text{ s}^{-1}$ are fixed within rather narrow limits by a variety of constraints imposed by beam-beam effects, acceptable wall plug power, damping ring and linac beam dynamics, and final focus optics. Taking these constraints into account in so far as they are presently known, R. Palmer [12] has computed sets of consistent collider parameters at several RF wavelengths. A tentative conclusion is that the RF wavelength for a viable collider design will be the range 1 to 3 cm. Table 1 gives some selected parameters from Ref. [12] for collider designs at three wavelengths in this range. A wall plug power of 50 MW per linac (based on an RF power source efficiency of 36%), flat beams with an aspect ratio of 180 to 1, and one bunch per RF fill are assumed. The active length of the main linac is 3.0 km, assuming a gradient of 186 MV/m and operation 27° off-crest to compensate for the single bunch beam loading energy spread and to introduce an energy spread for Landau damping. An additional 200 m length of linac is required to remove this latter spread, and about 200 m is required for focussing quads. A SLAC-type disk loaded structure with a group velocity $v_g/c = 0.08$ and an attenuation parameter $\tau = 0.25$ is assumed. The extraction efficiency per bunch is 1.2%, leading to a beam power of 140 kW. For details on the damping ring and final focus designs, see Ref [12]. It should be emphasized that these parameters are still evolving, and some of them may change significantly in response to progress both in theory and experiment.

5. CONCLUDING REMARKS

As mentioned previously, an active R&D program is underway at SLAC to demonstrate that an RF power source can in practice generate the high required peak power in the wavelength range given in Table 1. The focus at present is on the relativistic klystron approach, although a parallel experimental effort is also continuing to develop a practical RF pulse compression system. Accelerating structures with reduced wakefields are being investigated using 2D and 3D computer codes. Structures with greatly reduced long-range deflection wakes will be necessary if multiple bunches per RF pulse are to be accelerated and collided successfully. Multibunch acceleration is the only way known at present that can produce a luminosity of $10^{34} \text{ cm}^{-2} \text{ s}^{-1}$ with a reasonable wall plug power. Work at SLAC on damping ring and final focus designs for a future collider has so far been mostly theoretical. However, experience with the SLC is currently providing important practical information on these and other collider systems. Experiments with the SLC which would be relevant to the design of a future collider are also being planned; for example, the production and collision of flat beams.

Although this report has focussed on work at SLAC on future linear colliders, it is important to note that significant contributions have been made by our colleagues at other laboratories in the U.S. and abroad, in particular LBL, LLNL, CERN, DESY and KEK. A continued and even enhanced collaboration will most certainly be required to solve the numerous and difficult problems, both theoretical and experimental, that lie along the road to a successful TeV linear collider.

Table 1. Collider parameter at 3 RF wavelengths [12]

Beam Parameters		Wavelength (mm)		
		26	17	12
Luminosity	($10^{33} \text{ cm}^{-2} \text{ s}^{-1}$)	1.7	1.3	1.0
Beamstrahlung loss	(δ)	.33	.17	.10
Quantum parameter	(Υ)	1.8	1.5	1.2
Collision frequency	(Hz)	100	220	500
Particles per bunch	(10^{10})	1.8	0.8	0.35
Vertical spot size	(nm)	1.3	1.0	0.8
Horizontal spot size	(μm)	0.23	0.19	0.15
Bunch length	(μm)	40	26	18
Disruption	(D_y)	14	6	3
<u>RF Structure</u>				
Peak power	(GW/m)	1.2	1.0	0.82
Pulse length	(ns)	45	25	14
Iris radius	(mm)	5.2	3.5	2.3
Length per feed	(m)	1.2	0.65	0.35
<u>Damping Ring</u>				
Normalized vertical emittance	(10^{-8} m)	3.5	2.5	1.8
Normalized horizontal emittance	(10^{-6} m)	3.5	2.5	1.8
Energy	(GeV)	1.0	1.04	1.09
Radius	(m)	14.6	18.2	23.3
<u>Final Focus</u>				
Vertical β^*	(mm)	.047	.043	.038
Horizontal β^*	(mm)	15	14	12
Final quad aperture	(mm)	.13	.10	.08
Crossing angle	(mrad)	4	2.2	1.2

REFERENCES

1. Mills, F. E., ed., Advanced Accelerator Concepts, Conf. Proc. No. 156 (American Institute of Physics, NY, 1987)
2. See for example Wilson, P. B., SLAC-PUB-4310 (1987)
3. Wang, J., and Loew, G., SLAC-PUB-4247 (1987)
4. Konrad, G., and Lee, T., private communication
5. Farkas, Z. D., AAS-Note 33, SLAC (1987)
6. Farkas, Z. D., and Wilson, P. B., SLAC-PUB-4088 (1987)
7. Palmer, R., private communication
8. Farkas, Z. D., IEEE Trans. Microwave Theory Techniques, MTT-34, 1036 (1986)
9. Granatstein, V. L. et al., IEEE Trans. Nucl. Sci. NS-34, to be published
10. Schnell, W., Ref. [1], pp. 17-36.
11. Allen, M., Ruth, R., and Barletta, W., private communication
12. Palmer, R., SLAC-PUB-4295 (1987)
13. Ruth, R., SLAC-PUB-4436 (1987)