

IMPROVING THE EFFICIENCY OF MICROWAVE DEVICES WITH A DOUBLE OUTPUT CAVITY*

K. R. Eppley, W. B. Herrmannsfeldt, T. G. Lee

Stanford Linear Accelerator Center,

Stanford, California, 94305

Abstract

Double output cavities have been used experimentally to increase the efficiency of high-power klystrons¹. We have used particle-in-cell simulations with the 2+1/2 dimensional code MASK to optimize the design of double output cavities for the lasertron and the 50 MW klystron under development at SLAC. We discuss design considerations for double output cavities (e.g., optimum choice of voltages and phases, efficiency, wall interception, breakdown). We describe how one calculates the cavity impedance matrix from the gap voltages and phases. Simulation results are compared to experience with the 150 MW klystron.

Principles of Double Output Cavities

For typical high power microwave devices, a single output gap generally only extracts from 40-50% of the total energy. Double output cavities have been used successfully in klystrons to increase this efficiency¹. To extract the maximum energy from two gaps, the first gap should have a low enough Q to extract some of the energy from the bunch, while having a fairly large inductive detuning so that some further bunching is done. The first gap extracts energy mainly from the front of the bunch while improving the bunching at the back. Generally the cavities are coupled together through a slot and the power is extracted through a single waveguide.

The simulations used the particle-in-cell code MASK². MASK simulates rf cavities by imposing the cavity voltage and phase as a boundary condition. The code calculates the induced rf current as described by Yu³. Briefly, the cavity modes are calculated analytically assuming constant field across the gaps. The product E·J is computed and integrated over the volume, and the amplitude and phase at the fundamental frequency are found by Fourier transform. A given gap voltage and phase plus the corresponding induced current determines the effective cavity impedance. For a given cavity impedance (or, for coupled cavities, for an impedance matrix), it is possible to solve iteratively for self-consistent voltages and phases. For this study we optimized the efficiency by adjusting the voltages and phases independently and then solved for the corresponding impedance matrix elements.

Zhao⁴ has derived relations between the diagonal and off-diagonal terms in the impedance matrix for a coupled double output cavity. We have described elsewhere⁵ how we apply his equations to solve for the impedance matrix using the voltages and currents from MASK. Without some relation between the matrix elements the system is underdetermined, having two equations with three unknowns. We use Newton's method to iteratively find a matrix which is consistent with the voltages and currents and also satisfies the Zhao constraint.

Not every coupled cavity system is stable. The stability criterion is that the magnitude of the beam conductance must be less than the circuit conductance between the cavities. This condition must be met for the three modes of the coupled cavity system.

Design Constraints

There are a number of factors involved in a realistic cavity design. Gap sizes must be large enough to withstand the voltage without breakdown or multipactor. A rule of thumb at SLAC is to keep the maximum electric fields anywhere on the cavity surface to no more than 300 kV/cm at S band. For typical rf cavities the maximum field strengths are about 1.5-1.6 times higher than the average field across the gap. Subject to this constraint, one wishes to make the gaps as narrow as possible to improve coupling and hence efficiency.

The tube diameter must be large enough to prevent significant interception before the final output cavity. A rule of thumb is to make the tube diameter about 30 per cent larger than the beam size at input. Some interception is permissible after the output cavities, but not more than about 500 watts/cm² average power for copper walls. For the walls between the two output cavities the requirements are more stringent, a maximum of about 2 kW average power, because the presence of the coupling slot impedes the heat transfer. One wishes to make the tube diameter as small as possible, consistent with these constraints, to improve the coupling with the beam and hence the efficiency.

For the mode of operation (pi or two pi, etc.), there is an optimum distance between cavities, depending on the beam velocity and the cavity tunings. The separation between the gaps cannot be too large, or it will be difficult to couple power through a slot. In practice, the slot should not be much longer than about a centimeter.

Optimization of the Lasertron Cavities

Following the work by Welch⁶ for a lasertron with a single output cavity, we used a trapezoidal pulse shape approximating a Gaussian with FWHM of about 60 ps. The average current was 124 amperes, with beam voltage of 400 kV, for a microperveance of .49. With a single cavity we obtained a maximum efficiency of about 63 per cent. This is higher than that of the 50 MW klystron because the lasertron has better bunching and lower perveance.

To add a second cavity we extended the solenoid to 15.3 cm. We used slightly narrower gaps (16 mm) because the voltages for the two gap system would be lower. This gap width satisfies the 300 kV/cm limitation for gap voltages around 300 kV.

The cavity parameters were optimized for maximum efficiency with a two pi mode. The optimal phase differences between gap voltages and currents were about .7 radians (inductive) for gap 1 and .1 radians (capacitive) for gap 2. The optimum voltages for the 400 kV beam were 295 kV on

* Work supported by the US Department of Energy, contract DE - AC03 - 76SF00515.

both gaps. The optimal separation between gap centers was 68 mm. Efficiency was improved by reducing the tube diameter to 14 mm at the first gap, where the beam is most focused by the magnetic field. The beam expands afterwards and the tube was expanded to 15 mm beginning at 20 mm after the end of the first gap. (See Figure 1.) To improve clearance, the anode mouth was kept at a radius of 18 mm until within 8 mm of the first gap. The coil current was also increased slightly to 50000 ampere turns (peak field of 1790 gauss). The efficiency was then calculated at 76.5%.

Figure 1
Lasertron Geometry (dimensions in mm)

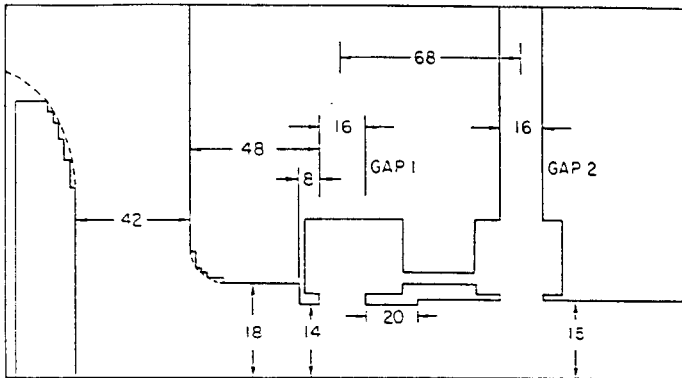

Figure 2
Electron Position-Space Distribution

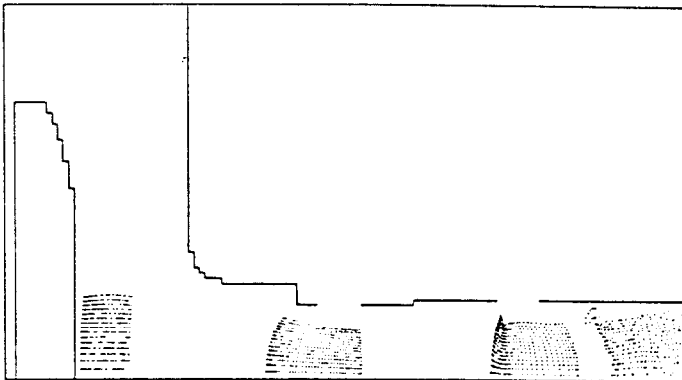
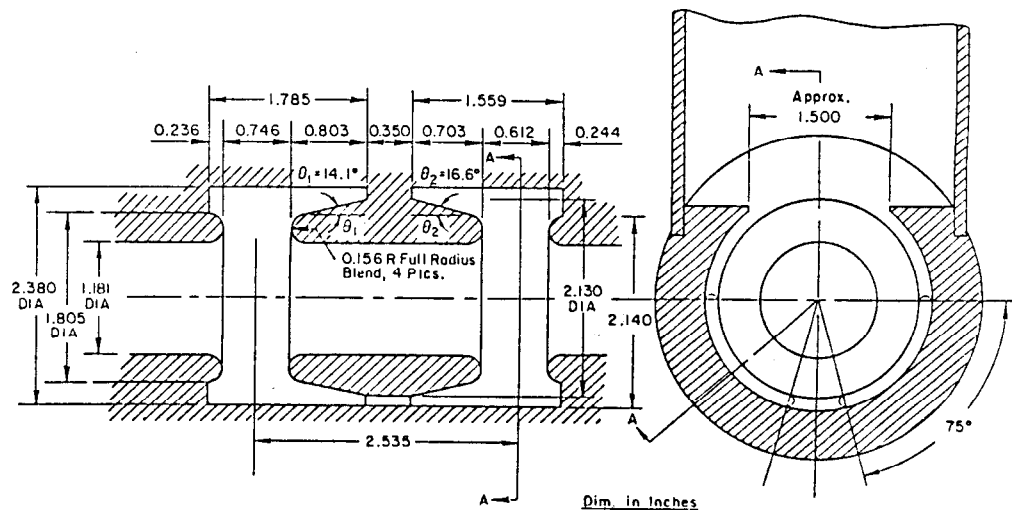

Figure 3
Actual Cavity Dimensions



The voltages and currents were:

$$\begin{aligned} V_1 &= 2.95 \times 10^5 \exp(-.098i) \\ V_2 &= 2.96 \times 10^5 \exp(-.356i) \\ I_1 &= 172 \exp(-.807i) \\ I_2 &= 126 \exp(-.242i) \end{aligned} \quad (1)$$

Imposing the Zhao conditions, we solved for the impedance matrix:

$$\begin{aligned} Z_{11} &= 1384 \exp(.619i) \\ Z_{22} &= 1523 \exp(.108i) \\ Z_{12} &= 1356 \exp(.272i) \end{aligned} \quad (2)$$

(Voltages above were defined at the walls. The impedances are all axis values. The conversion from wall to axis impedance is made by dividing by the square of the ratio of the voltage on the wall to the voltage on axis.)

Construction of the Actual Cavity System

A double output cavity based on the design above was built by Terry Lee (see Figure 3). It was not possible to match the computer optimized values exactly. The best approximation achievable in practice was measured to have the following (axis) impedances:

$$\begin{aligned} Z_{11} &= 1310 \exp(.162i) \\ Z_{22} &= 1760 \exp(.154i) \\ Z_{12} &= 1517 \exp(.154i) \end{aligned} \quad (3)$$

We were able to iterate the MASK runs to obtain a set of voltages and currents consistent with these impedances. The simulation predicted an efficiency of 73.6% or about 3 points less than the optimized value.

Application to the 5045 Klystron

Double output cavities have also been designed for the 5045 klystron. We began with the klystron geometry designed by Lee based on one dimensional calculations using the DISK code. This used the same locations for cavities one through three as the standard klystron, with tunings 2860, 2865, and 2870 MHz respectively. Cavity four was moved downstream to a position 40.3 cm from the input cavity, and was tuned to 2980 MHz, to act effectively like a penultimate cavity in the single output cavity tube. Cavities five and six were to be coupled together as the output cavities. Cavity five was 49.2 cm and cavity six was 55.5 cm from the input cavity. Gap sizes of cavities one to three were standard, cavity four was 1.1 cm, and cavities five and six were 1.62 cm. The impedances of the two output cavities were all taken to be 800 ohms (defined on axis) with zero phase. (This means that both cavities would have equal voltages and phases.)

The DISK calculation showed about 10 percentage points improvement in efficiency using these values compared to a single gap, with a saturation drive level of about 2 kW. The MASK simulation of this configuration also showed a saturation requirement of between 1-2 kW, but showed an improvement of only about 3 points over a single cavity.

Therefore we attempted to improve the efficiency by adjusting the cavity positions and impedances. Simulations were run for an input beam of 350 kv at microperveance 1.9. Initially we tried scaling the values found from the lasertron simulation. This corresponded to equal voltages (with rf gap voltage of about .75 of the dc beam voltage) on both output cavities with a phase difference of about .7 on cavity 5 and -.1 on cavity 6. However, this produced only a few points improvement over a single cavity. Therefore we tried unequal voltages on the last two cavities. By using fairly low voltages on cavities 4 and 5 (about 190 kV), a phase shift of about .8 radians on cavity 5, and voltage of 300 kV on gap 6, we calculated an efficiency of 55.5% versus about 45% for a single gap simulation with an output Q of 16.5. The optimum (wall) voltages and currents were found to be:

$$\begin{aligned} V_1 &= 1.87 \times 10^5 \exp(.908i) \\ V_2 &= 3.01 \times 10^5 \exp(.856i) \\ I_1 &= 422 \exp(.150i) \\ I_2 &= 310 \exp(.957i) \end{aligned} \quad (4)$$

We solved to find the corresponding (axis) impedances:

$$\begin{aligned} Z_{11} &= 322 \exp(.351i) \\ Z_{22} &= 812 \exp(.245i) \\ Z_{12} &= 510 \exp(.294i) \end{aligned} \quad (5)$$

As in the case of the lasertron, the actual cavities did not equal the computer design exactly. Somewhat fortuitously,

although the cavities were initially built with the intention to produce the equal impedance values from the DISK design, the measured values were closer to the impedances from the MASK design:

$$\begin{aligned} Z_{11} &= 544 \\ Z_{22} &= 881 \exp(.17i) \\ Z_{12} &= 692 \exp(.17i) \end{aligned} \quad (6)$$

When the MASK simulations were rerun with these impedances, an efficiency of 54.5% was found. A tube with these parameters is currently being designed.

Figure 4
Klystron Electron Position-Space Distribution
(Cavity Gaps Indicated by Slots on Top Boundary)

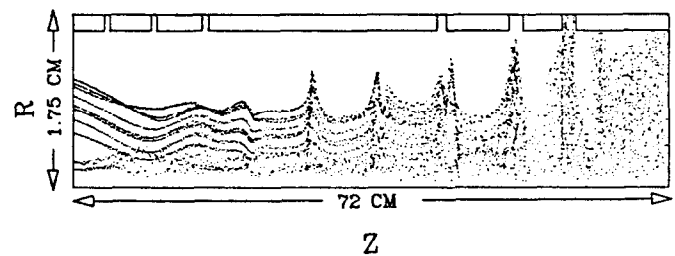

Conclusions

Simulations indicate that adding a second coupled output cavity to a high power microwave device can improve its power output by about 20%. These results are consistent with observations on the 150 MW klystron. For that tube efficiency improved from 43% to 51% with the addition of the second output cavity, i.e., a power improvement of 18.6%.

References

1. T. G. Lee, G. T. Konrad, Y. Okazaki, M. Watanabe and H. Yonezawa, "The Design and Performance of a 150 MW Klystron at S-Band," SLAC-PUB-3619, April 1985.
2. A. Palevsky and A. T. Drobot, "Application of E-M P.I.C. Codes to Microwave Devices" in Proceedings, Ninth Conference on Numerical Simulation of Plasmas, paper PA-2, Northwestern University, Evanston, Illinois, June 30-July 2, 1980.
3. S. Yu, "Particle In Cell Simulation of High Power Klystrons," SLAC/AP-34, September 1984.
4. Y. Zhao, "An Impedance Measurement Method for Double-Gap Klystron Cavity," IEEE Transactions on Electron Devices, Vol. ED-29, No. 2, February 1982, pp. 316-320.
5. K. Eppley, "Optimization of a Lasertron Double Output Cavity," SLAC/AP-48, February 1986.
6. J. Welch, "Efficiency and the Lasertron," SLAC, September, 1985.