

ELECTRONIC TRIGGER FOR THE ASP EXPERIMENT*

Robert J. Wilson

Stanford Linear Accelerator Center,
Stanford, California 94305

ABSTRACT

The ASP¹ electronic trigger is described. The experiment is based on an electromagnetic calorimeter composed of arrays of lead glass blocks, read out with photo-multiplier tubes, surrounding the interaction point at the PEP storage ring. The primary requirement of the trigger system is to be sensitive to low energy (≈ 0.5 GeV and above) photons whilst discriminating against high rate backgrounds at PEP. Analogue summing of the PMT signals and a sequence of programmable digital look-up tables produces a "dead-timeless" trigger for the beam collision rate of 408 kHz.

1. INTRODUCTION

The appropriateness of a talk on a trigger designed for an electromagnetic calorimeter, with less than a thousand channels, at a low energy (few tens of GeV) electron-positron collider at a workshop for a multi-TeV proton machine with barely an electron in sight, is open to debate. But enlightenment often comes from the most unlikely sources so I will proceed.

Figure 1 shows the basic timing scheme for most of the PEP experiments. The timing is driven by the storage ring RF clock which has a frequency of 408 kHz, this implies that the first level trigger must be completed within about $2 \mu\text{s}$. For those experiments requiring a precision t_0 , this clock is used to gate the fast pick-off signal from the passage of the electron or positron bunch.

* Work supported by the Department of Energy, contract DE – AC03 – 76SF00515.

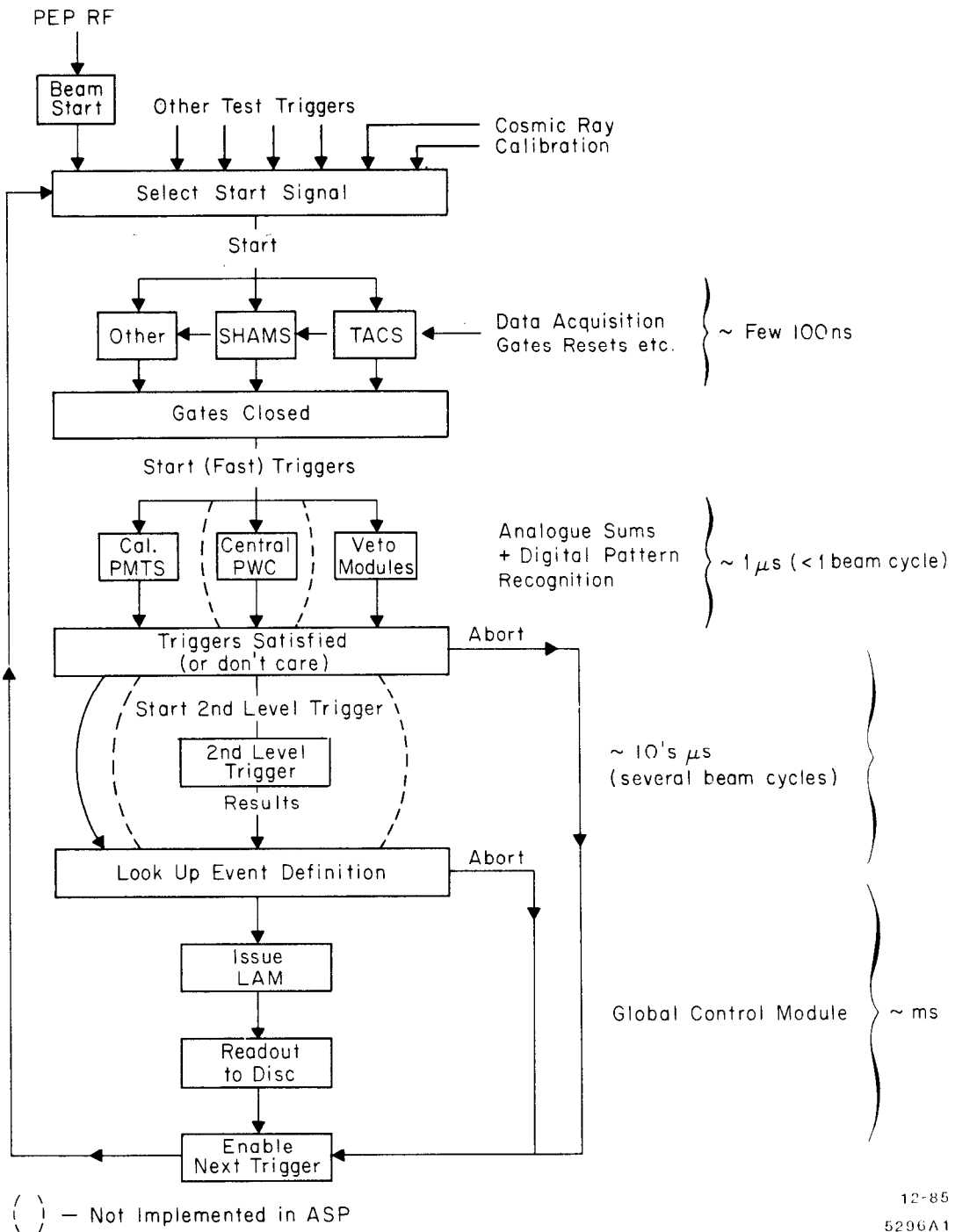

Figure 1. Flow chart of the overall trigger timing.

In the ASP system the synchronisation of the various decision making, data acquisition, event readout etc. is controlled by a central unit, the Global Control module. Figure 2 indicates the basic functions of the Global Control module. The external clocks, gates etc. are NIM levels whereas the internal logic is implemented in TTL. The signal at the START IN input determines the repetition rate of the system and is normally the PEP RF clock. It was found to be very useful, during both the debugging and subsequent testing *in situ*, to be able to run the system with different clocks. By using a CAMAC programmable twelve-pole router,² we could switch between any of twelve different signals without re-arranging cables.

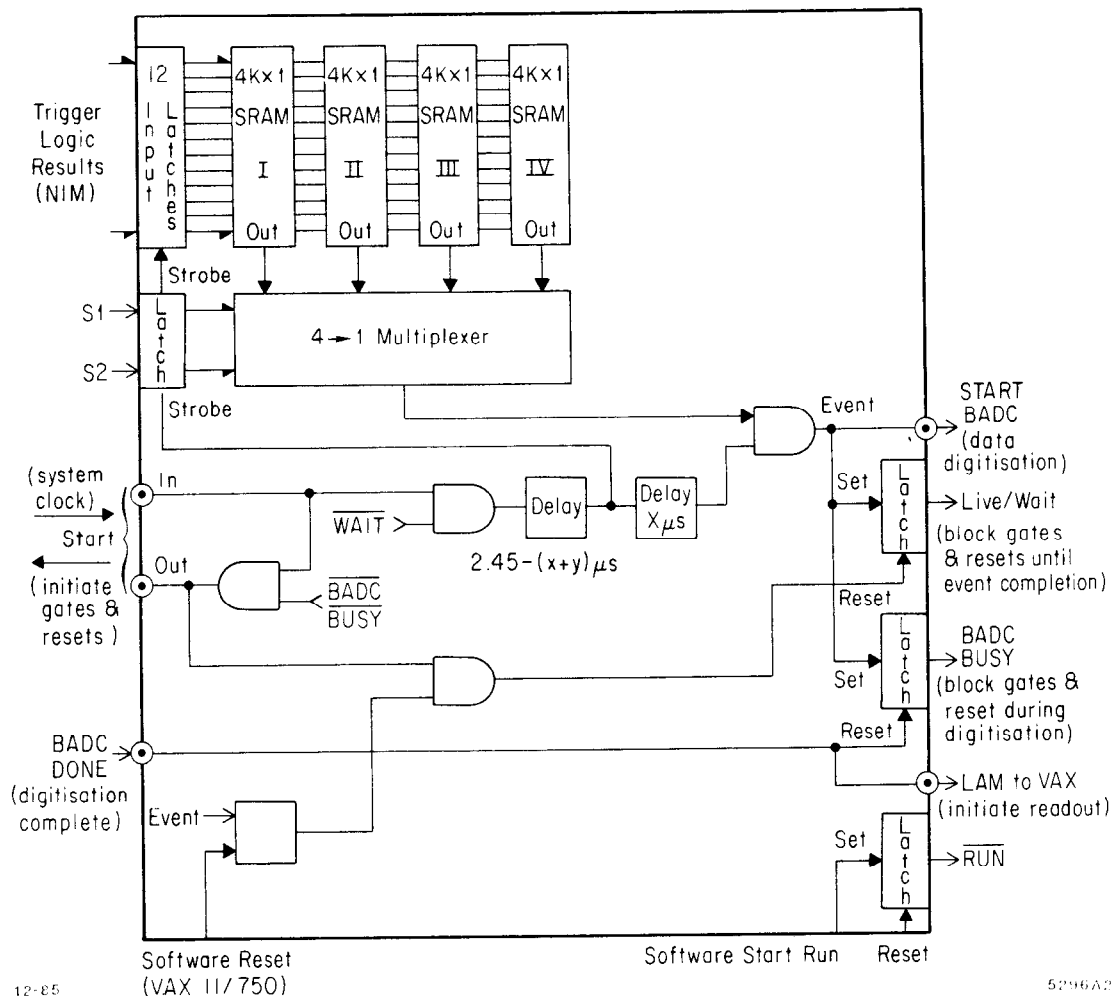

Figure 2. ASP Global Control Module.

A signal at START IN begins an internal timer; at some fixed time later ($\approx 1 \mu\text{s}$) the INPUT LATCHES are strobed. After this strobe it takes about 100ns for the four 4Kx1 RAM memories to settle and indicate whether an event pattern has been recognised. This takes approximately 100ns. If an event flag is set the LIVE/WAIT/BADC BUSY lines are asserted to block the system reset for this event. Simultaneously the START OUT is blocked which prevents further gates and resets from being generated.

Digitisation of the data in the SHAM-BADC³ system commences. When this is complete ($\approx 10 \text{ ms}$) a BADC DONE signal is received at the Global Control which releases the inhibit from the SHAM gates/resets. The trigger and the gates/resets to the backup digitisation⁵ crate remain disabled until the read-out has finished. Upon completion of the readout ($\approx 10 \text{ ms}$) the host computer (VAX11/750) initialises the Global Control module, allowing the cycle to repeat.

An important feature of the Global Controller is the degree to which it may be tested once installed in the system. All of the input and output latches may be set and reset; each of the pulsed outputs (to initiate the digitisation, for example) may be strobed and enabled or disabled. The input latches may be set to imitate trigger results and the unit instructed to initiate a normal cycle. Hence the bit patterns in the memories may be thoroughly tested at frequent intervals during a data run.

2. ANALOGUE SECTION

The ASP detector is shown in Fig. 3. Photons produced at central polar angles are detected in five-layer stacks of lead-glass bars interleaved with proportional wire chambers (PWCs). The glass bars are $6 \text{ cm} \times 6 \text{ cm} \times 75 \text{ cm}$, and each is read out by a single phototube. It was found to be unnecessary to use the PWCs in the trigger (although an analogue sum channel has been incorporated into the pre-amplifier card for each group of eight cells in case the information is needed).

Charged particles are tracked between the beam pipe and central calorimeter by planes of proportional tubes with resistive sense wires parallel to the beam line. This device was also outfitted to provide a sum signal but was also not used in the trigger. The central tracker is surrounded by 2 cm thick veto scintillators with phototubes on both ends. These scintillators were used to form a special trigger which selected cosmic rays and as a veto to the total energy trigger at the lowest threshold.

In the forward regions of the detector, two sets of lead-scintillator calorimeters were used in the trigger to select Bhabha scattered electrons and to veto

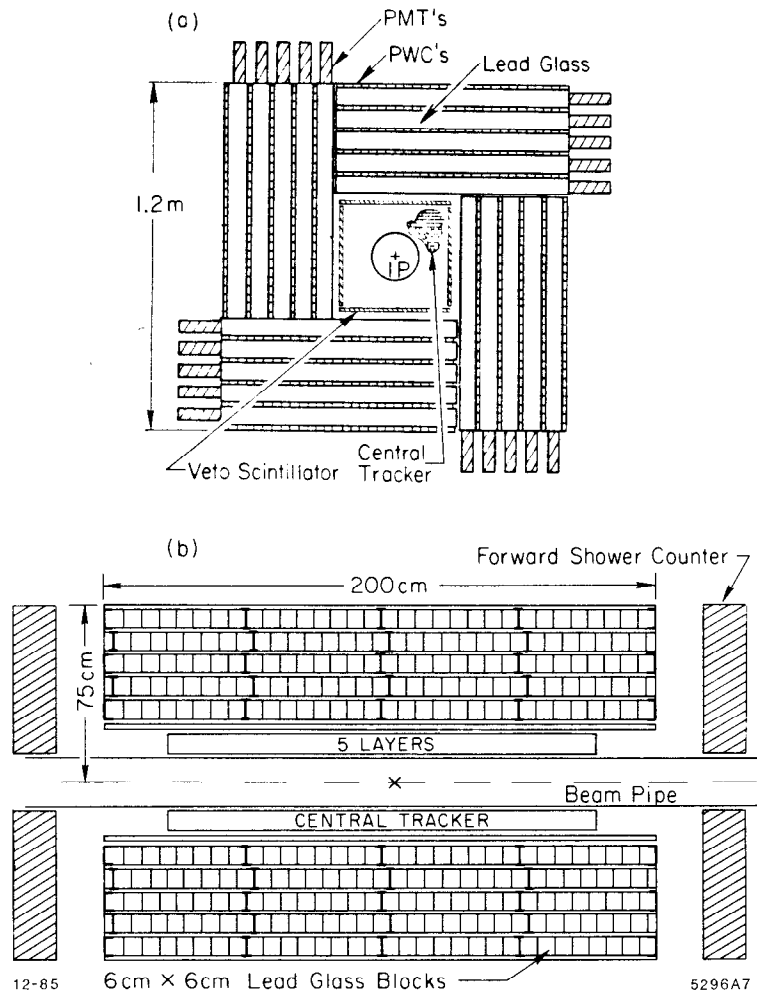
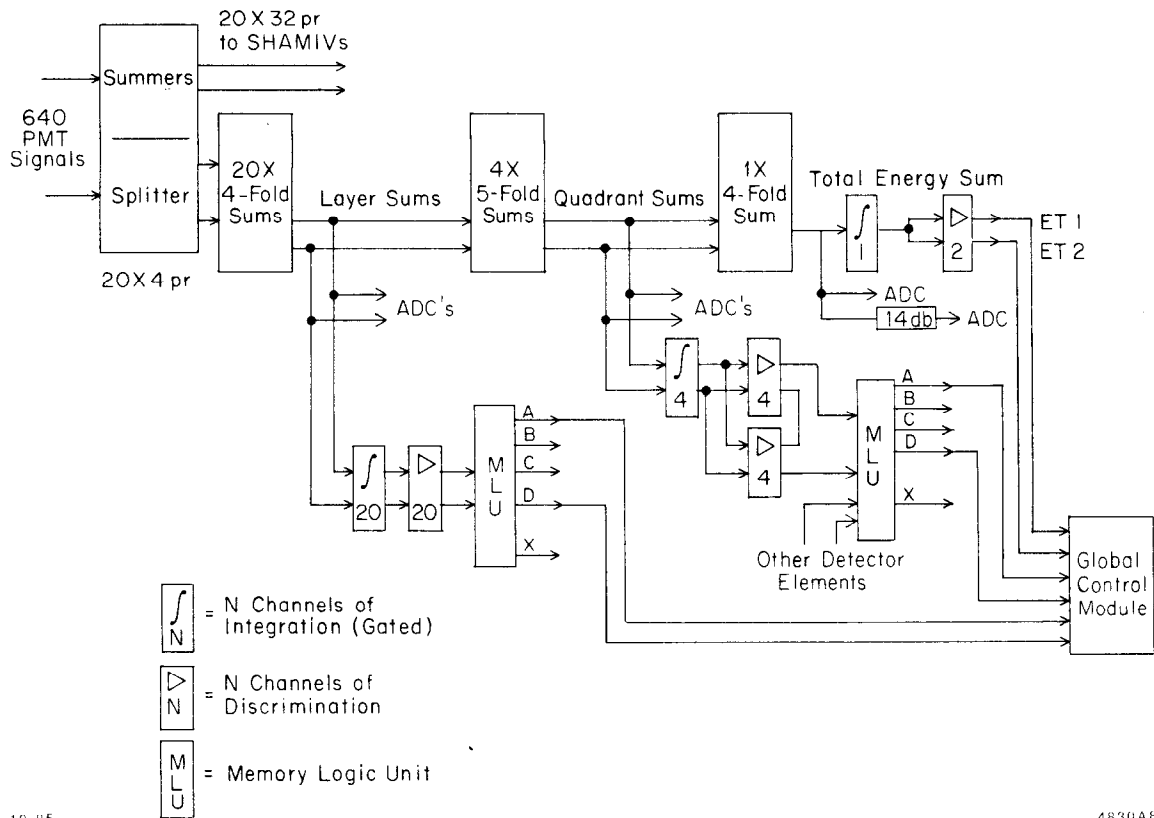

Figure 3. (a) Cross sectional view of the ASP central calorimeter and tracking system. Only a section of the central tracker is shown; it completely surrounds the I. P. (b) Side view of two quadrants of the central calorimeter, showing the grouping of the first sums of eight channels.

against beam-gas interactions which are the major source of "single photon" triggers. This trigger was constructed from simple analogue sums of all of the PMT signals in each module (four modules with four PMTs each), which are split and passed into discriminators of various threshold levels. The discriminated outputs form a bit pattern which is interpreted and merged with information from other sections of the apparatus in the Memory Logic Units (described later).

Figure 4 shows the scheme for forming the lead-glass "energy" triggers. The 632 individual PMT signals are transmitted along 16-pair twist-and-flat

cable to the Splitter/Summer unit. This unit divides the incoming signal into two branches. One branch is passed on to the data acquisition sample and hold modules;³ the other branch is summed with seven adjacent channels for use in the trigger. Hence, from these twenty NIM units we have 80 analogue signals each of which corresponds to one quarter of one layer (see Fig. 3b).



12-85

4830A8

Figure 4. Analogue Trigger Schematic.

The 80 signals are then further summed, in groups of four, to form an analogue signal whose total charge is proportional to the energy deposited in a single layer of the calorimeter. The summing was performed by a commercial Linear Fan-In/Fan-Out⁴ module. One copy of the summed output was sent to be digitised in a set of Analogue-to-Digital Converters,⁵ these are used as a redundancy check against the main acquisition system. Another copy goes to the next level of summing, a further copy is used to form a bit pattern of the hit layers.

Since the Fan-In/Fan-Out had only two outputs per channel and three were required, some additional fan-out was required. Originally, a passive 50 Ω splitter

was used to form the signals for the ADC and further summing routes. This led to the rude discovery that the LRS2249W ADCs introduced a small voltage spike on their *inputs* at the leading and trailing edges of the gate. These glitches were of no consequence to the layer sum discrimination. But, when summed to form the quadrant and total sums they added coherently to produce a signal above the nominal minimum energy threshold, giving rise to a trigger rate of 400 kHz! The summing section was re-arranged to avoid this problem with the addition of another set of Fan-In/Fan-Out modules.

Each of the sum signals (20 layer, 4 quadrant and 1 total) were integrated for the same duration (≈ 170 ns) as the sample and hold in the main data acquisition system. The integrations were performed by a SLAC designed Gated Integrator based on the SHAMIV circuit. The output of the integrator is a voltage level proportional to the amount of charge present at the input during the gate. The unit has a linear response from zero volts for no input charge, to a maximum of two volts for 500 pC at the input. Each unit contains 8 channels with a fan-out of three and occupies one standard NIM slot.

The results of the integration are discriminated⁶ to give a set of digital levels to be presented to the Memory Logic Units for analysis.

3. MEMORY LOGIC UNIT

The main elements of the ASP Memory Logic Unit (MLU) are shown in Fig. 5. The unit is a double width CAMAC module using NIM level inputs and outputs but implemented internally in TTL. The purpose of the MLU is to provide a flexible method of recognising patterns of hits in the various detector elements. It eliminates large numbers of NIM logic units often used for this purpose and allows for changes in trigger definitions in a simple manner.

The MLU may be used in either of two modes, "gated" or "free-run" and with the output either pulsed or a latched level. In the free-run mode the inputs are continuously active and the outputs follow the inputs. In the gated mode the inputs are latched and sampled *only* when the signal (corresponding to the PMT gate) at the GATE input is active. All operations of the unit are frozen when the WAIT input is asserted, and all latches are cleared by a RESET pulse.

The READY output may be used to cascade the MLUs. A READY signal signifies that the results of the logic look-up are available at the outputs and may be used as the "gate" for a subsequent MLU. Several READY signals may be ganged at the GATE input of another module so that it may process the output from several MLUs producing results asynchronously.

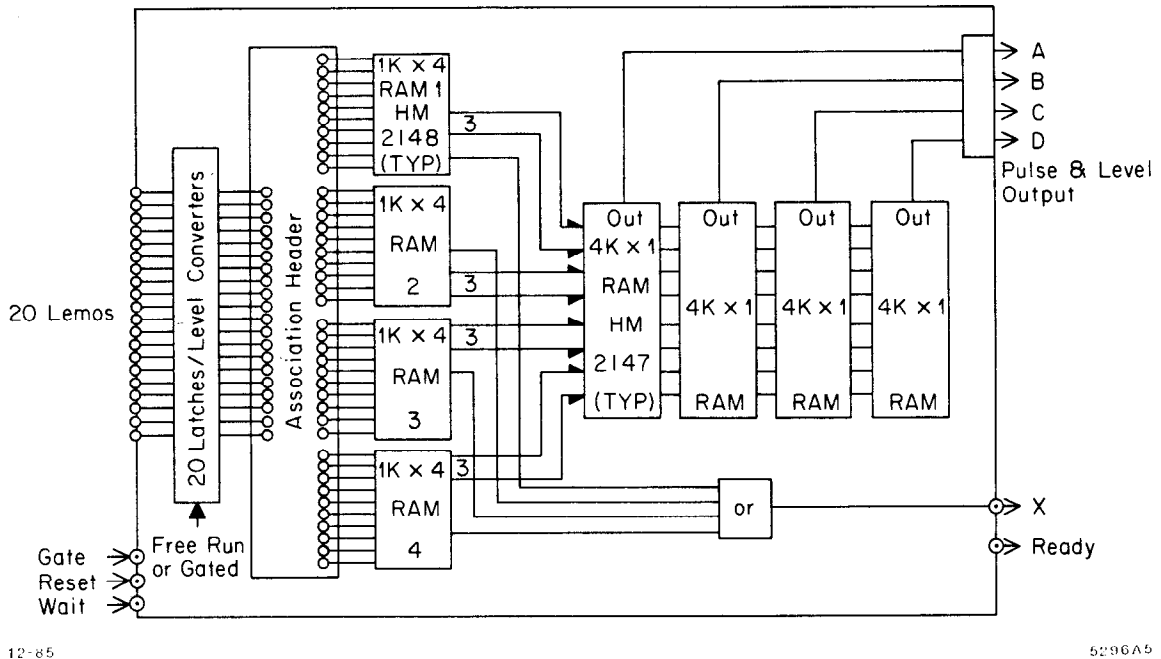

Figure 5. ASP Memory Logic Unit Block Diagram.

The data presented at the MLU inputs is processed in three steps. The first is a replaceable hard-wired Association Header. This header is used to map the 20 inputs onto the 40 address lines of four 1Kx4 RAMs. Since a TTL output can drive up to 10 standard TTL inputs, each of the MLU inputs could be attached to each of the memories if necessary. Figure 6 shows the header implementation that we used to recognise an electromagnetic shower which passes through the region of the calorimeter where two quadrants come together at the "corners" (see Fig. 3a). In this case the 20 inputs are the 20 hit layer signals (5 layers in each of 4 quadrants). By fanning out each layer signal to two RAMs we can look for patterns across the quadrant boundaries. The header used in our other applications simply associated one input to one address line and all of the logic was contained in the programmable memory bit patterns.

Of the four output bits from each level 1 RAM, one goes directly to a logical OR to form a prompt result at the X output. The other 3 bits are used to form the 12 address lines of each of four 4Kx1 RAMs. This allows the results of the previous look-ups to be merged in four different ways giving the four outputs A-D.

The memories used have typical access time of ≈ 80 ns but faster (35 ns) chips are available. The total time from the end of the gate to data ready is 300 ns.

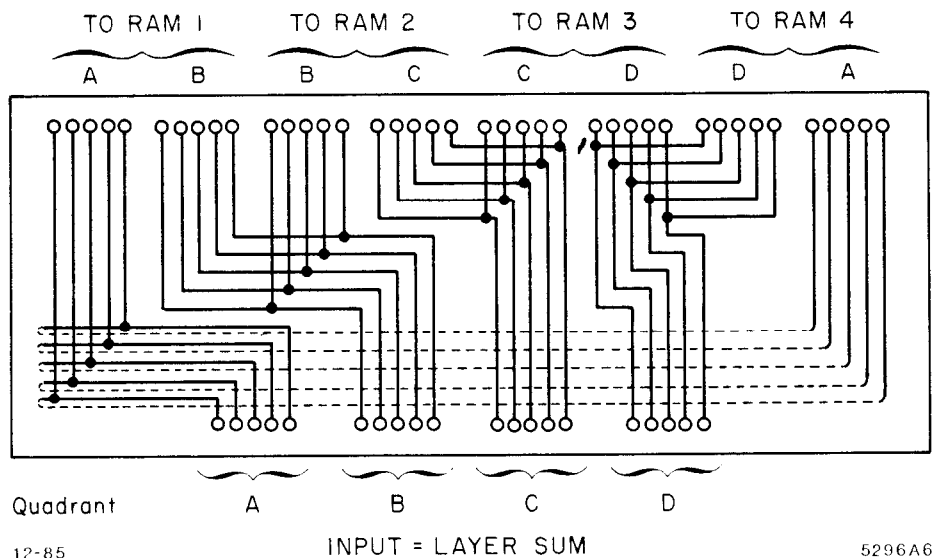

Figure 6. Association Header for Quadrant Logic.

4. SUMMARY

In summary the ASP trigger uses analogue summing of up to 632 PMT signals to form "energy clusters" of varying granularity. These clusters are then discriminated to form digital patterns which correspond to the energy distribution in the apparatus. The analysis of this distribution is then performed using a series of programmable look-up tables allowing trigger definitions to be changed by simply down-loading a new bit pattern into the memories. The whole sequence of look-ups may be tested by writing test patterns to the MLU input latches and initiating a normal trigger sequence.

Using this system at PEP we were able to trigger on a global energy deposition (i.e. summing all of the photo-tube signals) of ≈ 1.5 GeV. By requiring that the energy be localised to one quadrant (or shared in adjacent quadrants) the energy threshold was lowered to ≈ 1.0 GeV. The lowest "single photon" energy threshold of ≈ 0.6 GeV was achieved by requiring that there also be sufficient energy in layers other than just layer one; this vetoed against a known beam-gas background.

Several other miscellaneous triggers (for cosmic rays, forward bhabhas etc.) were formed; one of particular interest here is the radiative bhabha trigger. This trigger required significant energy deposition in the forward calorimeters and some small amount of energy anywhere in the central calorimeter. A source of coherent noise, which is insignificant on individual channels, became the limiting factor on the total energy threshold which requires many analogue signals to be summed.

All of the trigger decisions were completed within a single beam crossing period and the 408 kHz crossing rate was reduced to the 5-6 Hz typical trigger rate without the need for a second level trigger.

The author wishes to thank Leo Paffrath, Bob Gray and Carolyn Burton of the SLAC Electronics Group. This work was supported in part by the Department of Energy, contract DE-AC03-76SF00515 (SLAC).

REFERENCES

1. Anomalous Single Photon Collaboration, see SLAC-PUB-3817 for a description.
2. SEN Electronique WBR2073: Single width CAMAC unit.
3. E. Cisnero *et al.*, IEEE Trans. Nucl. Sci. *NS-28*, (1981). M. Breidenbach *et al.*, IEEE Tran. on Nucl. Sci. *NS-25*, (1978).
4. LeCroy Research Systems models LRS628 and LRS428F.
5. LeCroy Research Systems model LRS2249W, 12 channel ADC.
6. Philips Scientific model PS710: Octal Discriminator, -25 mV minimum threshold; LeCroy Research Systems model LRS623B: Octal Discriminator, -30 mV minimum threshold.