

SLAC - PUB - 3694  
May 1985  
(A)

## BINARY PEAK POWER MULTIPLIER AND ITS APPLICATION TO LINEAR ACCELERATOR DESIGN\*

Z. D. FARKAS

*Stanford Linear Accelerator Center  
Stanford University, Stanford, California, 94305*

### ABSTRACT

The voltage gained by a charged particle traversing an accelerator section is proportional to the peak power into the section. Thus a high peak power results in high particle voltages in a relatively short distance, a practical requirement of high particle energy accelerators. Pulse compression is a means to obtain high peak power. This note describes a new method of pulse compression, the Binary Power Multiplier, (BPM) a device which multiplies rf power in binary steps. It comprises one or more stages, each of which doubles the input power and halves the input pulse length. Thus the BPM increases peak power by multiples of 2 by means of pulse compression. The active control element of the binary power multiplier operates at low power and only passive devices are needed in the high power portion. We will describe practical designs and derive the expression for their compression efficiency. We will illustrate the usefulness of pulse compression for accelerator design and compare accelerator power systems using the binary power multiplier with the pulse compression system currently in use at the Stanford Linear Accelerator Center.

*Submitted to Special Transaction Issue on  
New and Future Applications of Microwave Systems*

---

\* Work supported by the Department of Energy, contract DE - AC03 - 76SF00515.

## INTRODUCTION

The voltage gained by a charged particle traversing an accelerator section divided by the section length, the average gradient, varies as the peak power amplitude into the section. High gradients are especially important for a new type of electron-positron collider, the linear collider,<sup>1</sup> where two linear accelerators produce particle beams which are brought into collision once and then are discarded. This new type collider is more efficient at high particle energies than an electron-positron storage ring.

The first attempt to achieve electron positron-collisions with a linear collider is the Stanford Linear Collider<sup>2</sup> (SLC) presently nearing completion at Stanford Linear Accelerator Center (SLAC). While not a true linear collider (the SLC uses the SLAC accelerator to inject electrons and positrons into two arcs which bend the beams into collision), it will nonetheless serve the dual purpose of a unique physics tool and a demonstration of some aspects of linear collider technology. Proposed future positron-electron colliders<sup>3</sup> would be capable of investigating fundamental processes of interest in the 1-5 TeV beam energy range. At the SLC gradient of about 21 MV/m this would imply prohibitive lengths of about 50-250 kilometers per linac. We can reduce the length by increasing the gradient but this implies high peak power. Using the SLAC accelerator sections, operating at 2856 MHz, a 100 MV/m gradient requires 750 MW peak power.

Another requirement of Multi-TeV colliders is high average power. For a given gradient, both peak and average powers depend on section fill time. The peak power increases as we decrease the fill time from its value where the peak power has a broad minimum. On the other hand the average power decreases monotonically as the fill time is decreased. Thus we can reduce the average power at the expense of increased peak power. We can trade higher peak power for lower average power. Pulse compression is a means to obtain high peak power. It adapts the relatively long source pulse length to the relatively short accelerator section fill time. If we can compress with nearly 100% efficiency we can increase

peak power without increasing average power.

To produce the unloaded 21 MV/m SLC gradient which requires 160 MW peak power SLAC uses a compression system SLED<sup>4</sup> which compresses a 50 MW 5  $\mu$ s klystron pulse into an effective 160 MW 0.82  $\mu$ s pulse. (The fill time of the SLAC accelerator section is 0.82  $\mu$ s). SLED has the following shortcomings. Its maximum efficiency of 81% can only be reached at a compression ratio of about 3:1, and drops off sharply as the compression ratio deviates from 3:1. Moreover, the compressed pulse varies with time, which reduces the efficiency when it is used as the power input to an accelerator section. With the BPM we have a rectangular (flat) output pulse and if we reduce dissipation we can approach 100% efficiency. In its high power portion the BPM has only delay lines and 3dB couplers which are capable of carrying very high peak power. 3 dB side wall couplers tested at SLAC at 2856 MHz did not break down at peak power levels in excess of 500MW.

## GENERAL DESCRIPTION OF THE BPM

The Binary Power Multiplier (BPM) includes a front-end, a pair of high power amplifiers (klystrons), and one or more compression stages. Refer to Figure 1. The front-end consists of a power splitter and two biphas modulators which code the klystron inputs in time bins equal to the final compressed pulse length with either zero or 180° phase shift. The phase changes must occur in an interval short compared to the compressed pulse length. The klystron outputs are connected to one or more pulse compression stages. Each stage consists of a 3 dB hybrid with one output port connected to a delay line whose delay is half the input pulse length and the other output port connected to zero delay transmission line. Each stage converts its two coded inputs into two outputs whose power amplitudes are twice that of the two input amplitudes, and are appropriately coded for the next stage. An  $n$  stage BPM starts with two klystron pulses of unity power amplitude and  $2^n$  duration in units of the compressed pulse length, and ends up with two

pulses of  $2^n$  power amplitude and unity pulse length, assuming lossless delay lines. The active control elements of the BPM, the biphase modulators that do the coding, operate at low power, and only passive devices are needed in the high power portion of the BPM. The BPM can also transform a continuous wave input into a train of pulses although the output duty cycle is constrained to discrete values (powers of 2).

## SINGLE STAGE BPM

Because of its simplicity we explain first the operation of a single stage BPM which consists of a front-end and a single compression stage as shown in Fig. 1. The low level output of a single source is divided by the 3 dB coupler  $H_i$  to drive two high power klystrons  $K_a$  and  $K_b$ . Each pulse duration is determined by the klystron modulators  $M_a$  and  $M_b$  and is set to twice the compressed pulse length. The biphase modulator  $\phi_b$  codes the two klystron outputs as shown at (b) and (d) in Fig. 1. Here a plus sign indicates zero phase and a minus sign indicates a phase shift of  $180^\circ$ . Time is in units of the compressed output pulse length. The function of phase shifter  $\phi_v$  (not coded) is to ensure that the klystron outputs are precisely in phase or  $180^\circ$  out of phase. The two klystron outputs are connected to the two inputs of the 3 dB coupler  $H$ . The properties of the 3dB hybrid (with properly chosen reference planes) are such that if the phase of between the two inputs is zero the combined power appears at terminal  $O_1$  and when the phase is  $180^\circ$  the combined power appears at  $O_2$ . Terminal  $O_1$  of the hybrid  $H$  is connected to the delay line  $D$  whose time delay is the compressed pulse length. After a time interval equal to one half the input pulse duration the phase shift of biphase modulator  $\phi_b$  is changed by  $180^\circ$ . As a consequence, during the second half of the input pulse the combined output of the two klystrons exits terminal  $O_2$  of the hybrid. As the rf at terminal  $O_1$  is delayed by half the pulse duration the two outputs appear simultaneously at the two outputs of the BPM. The two klystron pulses are transformed into two output pulses; the duration of each pulse is one half and the peak power is double the output of a single klystron.

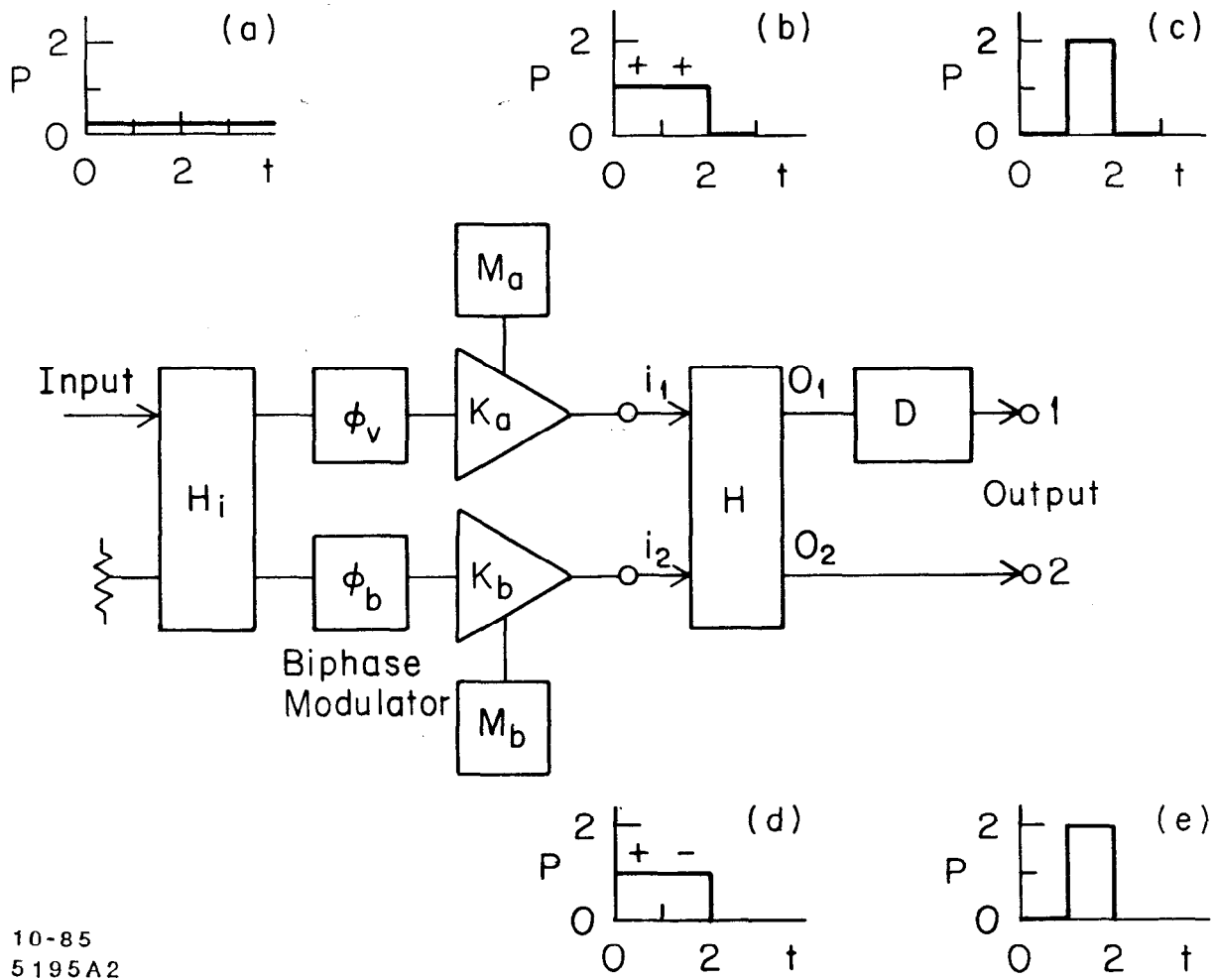

10-85  
5195A2

Figure 1. Diagram of a single stage BPM.

## MULTIPLE STAGE BPM

To obtain  $2^n$  power multiplication we place  $n$  stages in tandem and form an  $n$  stage BPM. The delay of the  $i$ th stage delay line is  $2^{n-i}T_f$ .  $T_f$  is the output pulse duration and  $i = 1, 2, 3, \dots, n$ . The input pulse length is  $2^n T_f$ .

To set the stage for the explanation of a multi-stage BPM we digress and discuss the 3dB hybrid in more detail. We arbitrarily designate two isolated ports of the hybrid as input ports, and the other pair as output ports. The properties of the hybrid are such that if power is supplied to input 1 the phase of the rf is the same at both output ports and if power is supplied to input 2 the phase of the rf at the two outputs are opposite. Using superposition we derive from the above properties the following rules:

1. If both inputs are supplied with power of equal amplitude and the same phase then the combined input power exits output 1.
2. If both inputs are supplied with power of equal amplitude and opposite phase the combined input power exits output 2.
3. The power exiting either output has the same phase as the power supplied to input 1.

Applying the above hybrid properties, we have the input coding for any stage:

1. Input 1 coding is the same as that of input 1 of the following stage during the first half of the pulse and is the same as the coding of input 2 of the following stage during the second half of the pulse.
2. Input 2 coding is identical to that of input 1 during the first half of the pulse and is opposite during the second half of the pulse.

As we know the input to the last stage we can work backward and determine the input coding for a multi-stage BPM. This is illustrated in Fig. 2, which shows the coding at each stage input of a 4 stage BPM. Plus signs indicate zero phase and minus signs  $180^\circ$ . Each phase lasts for a duration  $T_f$ .

Stage	1												2				3			4		0	
Input 1	+	+	+	-	+	+	-	+	+	+	-	-	-	+	-	+	+	+	-	+	+	+	
Input 2	+	+	+	-	+	+	-	+	-	-	-	+	+	+	-	+	+	+	-	+	+	-	+

Figure 2. Coding for a 4 stage BPM input stage and resultant coding at each stage input.

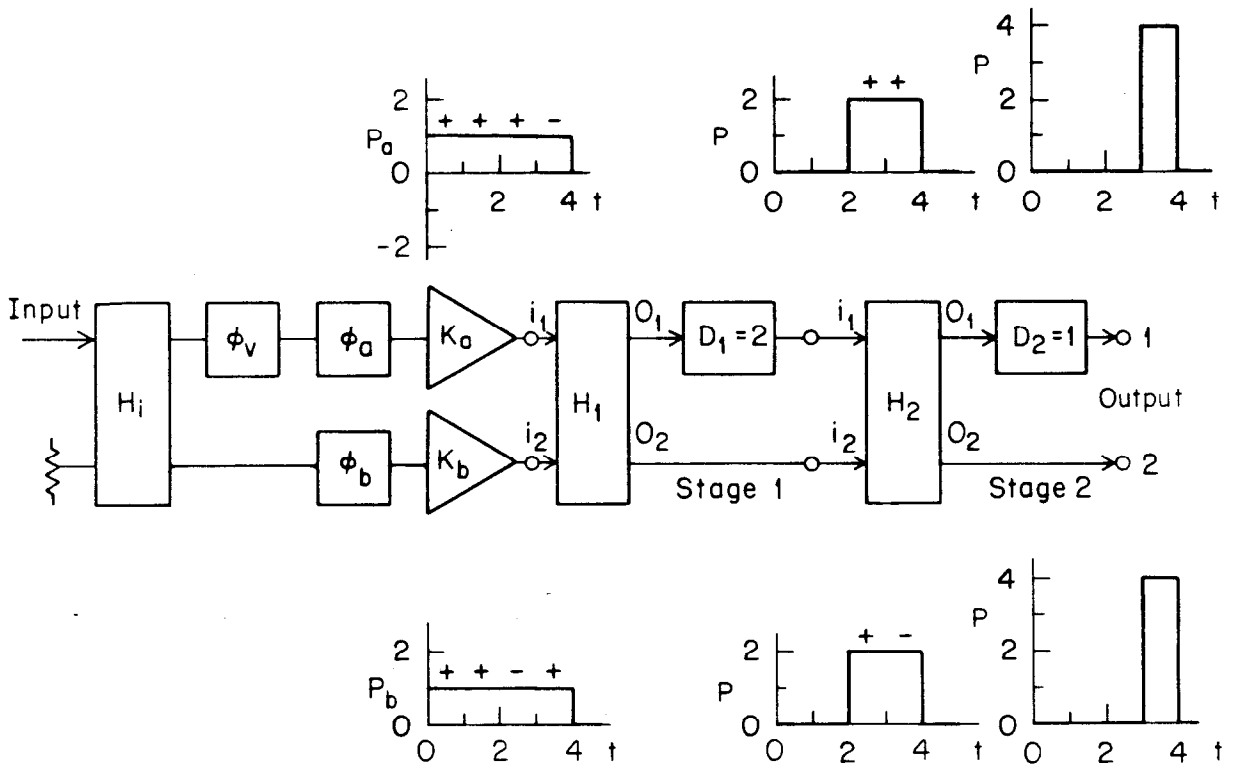

10-85

5195A3

Figure 3. Diagram of a two stage BPM.

A two stage BPM is shown in Fig. 3. A biphaser modulator  $\phi_a$  and an additional stage has been added to the single stage BPM of Fig. 1.

Clearly if we operate at low power the klystrons are not necessary. If we combine the two outputs of the last stage we have a single input pulse and a single compressed output pulse.

## COMPRESSION EFFICIENCY

The discussion in terms of power multiplication by  $2^n$  is based on the assumption that the dissipation losses are zero. Nearly zero dissipation is possible with short pulses and even with long pulses if the delay lines and couplers are superconducting or if they operate in the circular  $TE_{01}$  mode. But in general each delay line causes some attenuation, so that the power multiplication factor  $M_i$  for the  $i$ th stage is not 2, but rather

$$M_i = 1 + e^{-2\tau_i} \quad , \quad \tau_i = 2^{n-i} T_f \alpha_t \quad (1)$$

where  $\tau_i$  is the attenuation in nepers of the  $i$ th stage delay line,  $T_f$  is the duration of the output pulse, and  $\alpha_t$  is the attenuation in nepers per unit time delay.

The multiplication factor  $M$ , the ratio of the BPM output to input peak power amplitude, is the product of the multiplication factors of the individual stages:

$$M = \prod_{i=1}^n (1 + e^{-2\tau_i})$$

The compression efficiency is

$$\eta_{pc} = \frac{M}{2^n} \quad .$$

If the BPM is used to increase the peak power into an accelerator section then the compressed pulse length is made equal to the section fill time. To account



for the unequal powers into the two accelerator sections, the expression for the power multiplication factor of the last stage is slightly modified and is given by

$$M_l = \frac{(1 + e^{-\tau_f})^2}{2} \quad (2)$$

Here  $\tau_f$  is the attenuation of the last stage delay line. For small attenuation this reduces to the previous expression for a single stage power multiplication:  $M_l = 1 + e^{-2\tau_f} \approx 2(1 + \tau_f)$ .

The attenuation is proportional to the time delay and therefore to obtain high efficiencies for large compression factors or for long compressed pulses we must have delay lines with low attenuation per unit time delay.

## DELAY LINE DESIGN

The delay lines can be sections of loaded or unloaded waveguides. For either loaded or unloaded guide the attenuation in nepers per unit time delay  $\alpha_t = p_d/2w$ . Here,  $p_d$  is the power dissipated per unit length and  $w$  is the energy stored per unit length. The total attenuation for a section with a time delay  $T_d$  is  $\tau_d = \alpha_t T_d$ . The attenuation per unit time delay is the attenuation per unit length multiplied by the group velocity.

A smooth waveguide delay line is preferred because its attenuation per unit time delay is less than that of the same diameter loaded line. The smooth line has the additional advantages that it is easier to manufacture, is easier to cool (especially important if the line is superconducting), has wider bandwidth and hence better step response, and is characterized by a lower field for a given transmitted power.

The dissipation by a guide operating in the circular  $TE_{01}$  mode decreases as the frequency increases, and can approach negligible loss. Low loss couplers are also available in this mode. Round guides operating in the  $TE_{11}$  mode have the

smallest diameter at a given frequency. For the above reasons we examine the  $TE_{11}$  and  $TE_{01}$  modes in round pipes. Their attenuation per unit time delay are

$$TE_{11} : \quad \alpha_t = \frac{R_s c}{a \eta} \left[ \left( \frac{\lambda}{\lambda_c} \right)^2 + 0.419 \right] \quad (3)$$

$$TE_{01} : \quad \alpha_t = \frac{R_s c}{a \eta} \left( \frac{\lambda}{\lambda_c} \right) \quad (4)$$

Here,  $c$  is the velocity of light,  $a$  is the radius,  $\eta$  is the free space impedance. For a copper pipe  $R_s = 0.0261\sqrt{f}$  and the attenuation in nepers per  $\mu s$  in a guide of diameter  $D$  (cm) operating at a frequency  $f$  (MHz) for the indicated modes are:

$$TE_{11} : \quad \alpha_t = \frac{0.0414\sqrt{f}}{D} \left[ \frac{3.09 \times 10^8}{D^2 f^2} + 0.419 \right] \quad (5)$$

$$TE_{01} : \quad \alpha_t = \frac{5.56 \times 10^7}{D^3 f^{3/2}} \quad (6)$$

Plots of  $\alpha_t$  as a function of diameter for several frequencies are shown in Fig. 4. For  $\tau \ll 1$  the multiplication factor is  $2(1 - \tau)$  and the efficiency is  $1 - \tau$ . As  $\tau = \alpha_t T_d$ , we can estimate from these plots the reduction of the multiplication factor and of the efficiency due to attenuation.

However, smooth lines suffer the disadvantage that a 1 microsecond delay line is 300 m long. We overcome this problem by folding the line to make it compact. Figure 5 is a plan schematic illustrating the design of a two BPM stages using folded delay lines. The realization of the folded lines exploits the property of the hybrid that if the two output ports are shorted the power into the first input port exits the second input port traveling in the opposite direction. This is shown symbolically as heavy curved arrows through the coupling apertures

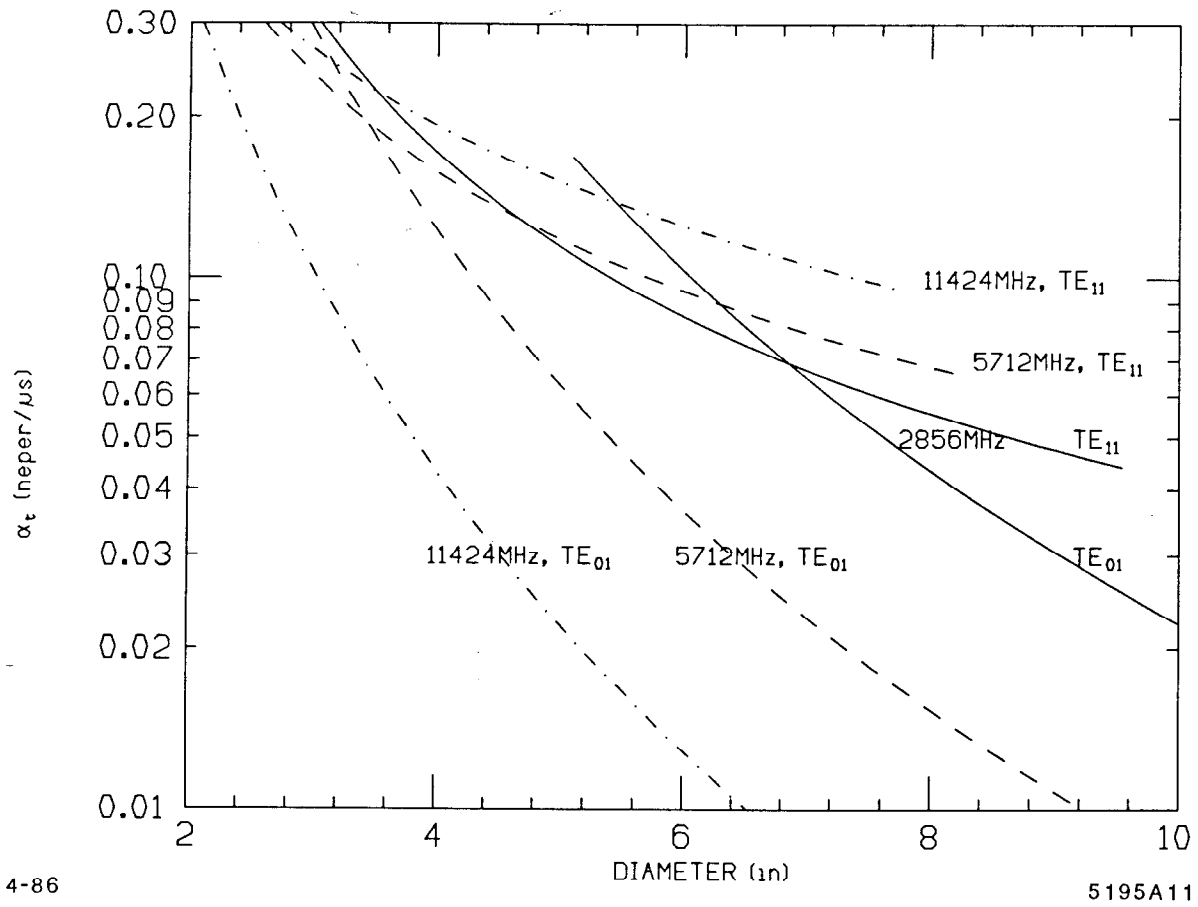

Figure 4.  $TE_{11}$  and  $TE_{01}$  attenuation as a function of diameter.

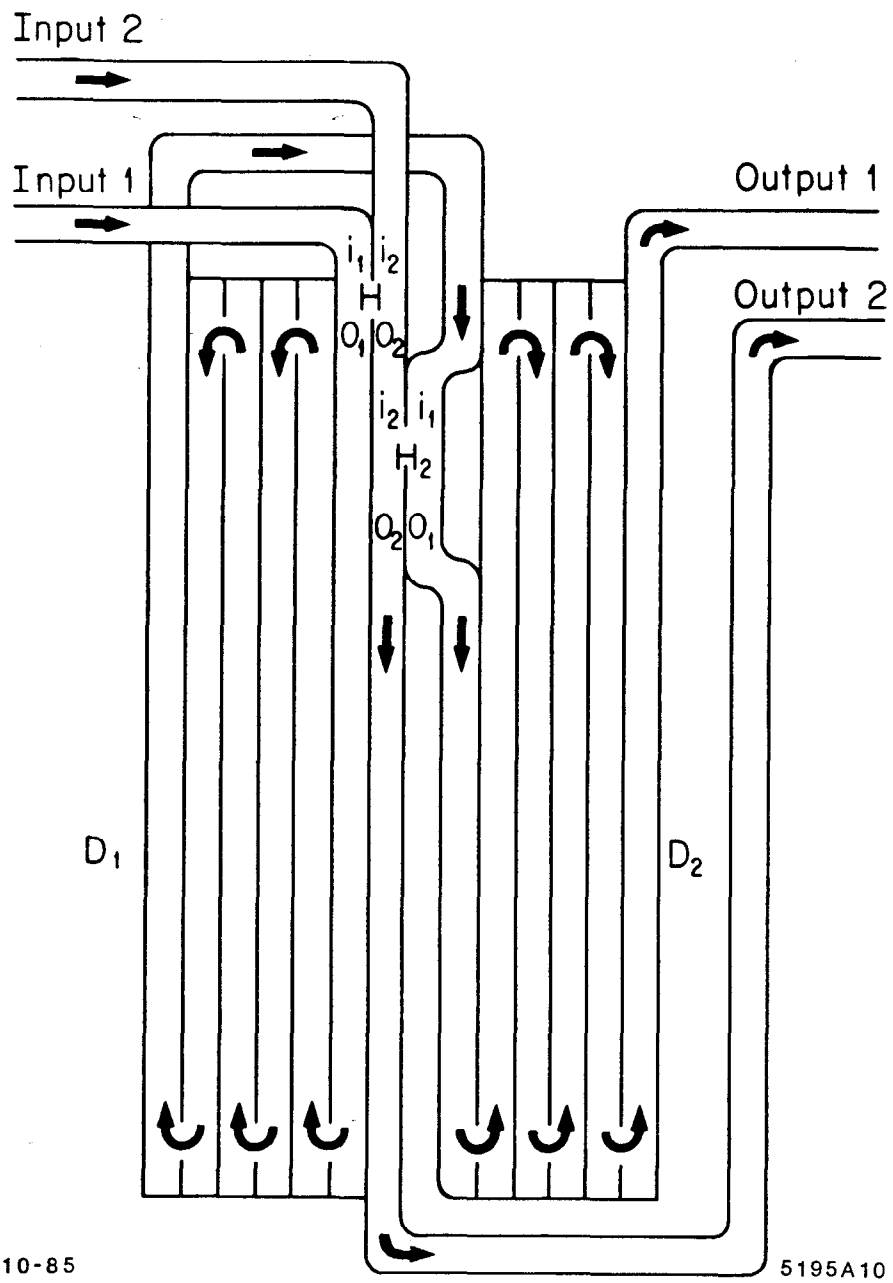

Figure 5. Two BPM stages using folded delay lines.

of the hybrids used to effect such reversal of direction. The direction of power flow in two adjacent lines can also be reversed by using a cavity to couple power between the two lines. The particular configuration of Fig. 5 indicates that the assembly could be put in commercially available vertical cryostats.

The delay lines can be shortened by loading the guide. A  $TE_{01}$  loaded line is most suitable because it carries no axial current and therefore it has the lowest attenuation per unit time delay. It is also easy to manufacture. Still, a smooth line has even lower attenuation. At 2856 MHz, for example, a low group velocity delay line made of 5.4 inch diameter  $TE_{01}$  coupled cavities has an  $\alpha_t = 0.163$  nepers/ $\mu$ s. A smooth guide with the same diameter, operating in the  $TE_{11}$  mode, has  $\alpha_t = 0.1$  nepers/ $\mu$ s. Thus lightly loaded  $TE_{01}$  delay lines seem to be a good compromise.

In addition to power lost by delay line dissipation, there is residual power loss because only when the two input powers to the hybrid are equal is it possible to adjust the phase between the two inputs so that all power exits one output with zero residual power at the other output. Fortunately, as will be shown, the ratio of residual power to power lost by delay line dissipation is itself proportional to dissipation loss. Since the delay line loss must be kept low in any case, the reduction in compression efficiency due to residual power loss is insignificant.

Consider the effect when the powers at the inputs of a hybrid coupler are unequal. Let the output to input power ratio of the delay line preceding input 1 of a hybrid be  $f^2$ . Consequently the power to input 1 of that hybrid is  $f^2$  times less than the power into its input 2. With no loss in generality it may be assumed that the power at input 1 is  $f^2$  and at input 2 is unity. Also assume that the coupling is  $C$ . If the phase is adjusted for maximum power at output 1, the two output powers  $P_{o1}$  and  $P_{o2}$  are:

$$P_{o1} = \left( f\sqrt{1-C^2} + C \right)^2 , \quad P_{o2} = \left( fC - \sqrt{1-C^2} \right)^2 .$$

For all power  $f^2 + 1$  to exit output 1 with no power at output 2 requires

$$C^2 = \frac{1}{1 + f^2} .$$

If the phase is adjusted for maximum power at output 2, the two output powers are:

$$P_{o1} = \left( f\sqrt{1 - C^2} - C \right)^2 , \quad P_{o2} = \left( fC + \sqrt{1 - C^2} \right)^2 .$$

For all power  $f^2 + 1$  to exit output 2 with no power at output 1 requires

$$C^2 = \frac{f^2}{1 + f^2} .$$

For equal power inputs, ( $f^2 = 1$ ), both conditions are satisfied if  $C^2 = \frac{1}{2}$ ; that is, the coupling is 3dB, and all power exits one output.

With unequal power inputs, there is no value of coupling that can satisfy both conditions. While it is possible to choose a coupling that causes all powers to exit one output only, this coupling will not permit all power to exit the other output. Since the BPM ideally requires all power be directed to either output, it is impossible to adjust the coupling to accommodate unequal power inputs.

Fortunately, the power ratio  $f^2$  is close to 1, since the delay attenuation is required to be low. Therefore a coupling of 3dB is nearly ideal; that is the residual power is small compared to delay line dissipation, and its effect on compression efficiency is small. For 3dB coupling,  $C^2 = \frac{1}{2}$ , the fractional residual power  $p_{or}$  at either output is:

$$p_{or} = \left[ \frac{f}{\sqrt{2}} - \frac{1}{\sqrt{2}} \right]^2 .$$

Let the fractional power loss by delay line dissipation be  $\delta$ , so that  $f^2 = 1 - \delta$ . Substituting  $\sqrt{1 - \delta}$  for  $f$  we have

$$p_{or} = 1 - \frac{\delta}{2} - \sqrt{1 - \delta} .$$

For  $\delta \ll 1$  this reduces to  $p_{or} = \frac{\delta^2}{8}$  which is of second order in  $\delta$ . The ratio

of the residual to dissipation power is therefore  $\frac{\delta}{8}$ . For example, for a 1dB delay line attenuation  $\delta = 0.26$ , and the residual power is only 1/24 of the dissipation power.

## ACCELERATOR DESIGN USING PULSE COMPRESSION

Before comparing systems we will derive the expressions for the system parameters when pulse compression is used. The energy required to reach an average accelerating gradient  $E_a$  in a lossless section is<sup>5</sup>

$$U_{as} = \frac{E_a^2 L}{s} .$$

Here  $L$  is the length of the section,  $s$  is the elastance per unit length. The klystron energy is this ideal energy divided by the rf-to-accelerating-energy conversion efficiency  $\eta_{rf}$ , which is in turn the product of the section efficiency  $\eta_s$ , the transmission line efficiency  $\eta_t$ , and the compression efficiency  $\eta_{pc}$ . The peak power  $P_{pk}$  and average power  $P_{ak}$  required to produce  $E_a$  are

$$P_{pk} = \frac{E_a^2 L}{s \eta_s \eta_t \eta_{pc} C_f T_f} , \quad P_{ak} = f_r \frac{E_a^2 L}{s \eta_s \eta_t \eta_{pc}} . \quad (7)$$

Here  $n_s$  is the number of sections per klystron,  $f_r$  is the pulse repetition rate,  $C_f$  is the compression factor. The power multiplication factor  $M = \eta_{pc} C_f$  the section efficiency  $\eta_s$  for a constant impedance section is

$$\eta_s = \frac{(1 - e^{-\tau})^2}{\tau^2} . \quad (8)$$

The section attenuation in nepers  $\tau$  and the section fill time (also compressed pulse length)  $T_f$  are<sup>6</sup>

$$\tau = \frac{T_f}{T_o} , \quad T_f = \frac{L}{v_g} \quad (9)$$

where  $v_g$  is the group velocity and  $T_o$  is the unloaded (internal) time constant. The values of  $s$ ,  $v_g$  and  $T_o$ , the three parameters that characterize a traveling

wave accelerator section, can be obtained from computer codes such as URMEL<sup>7</sup> and TWAP.<sup>8</sup> They are defined by

$$s = \frac{E^2}{w}; \quad v_g = \frac{P}{w}; \quad T_o = \frac{2w}{p_d} \quad (10)$$

where  $E$  is the accelerating gradient,  $w$  is the energy stored per unit length,  $P$  is the power transmitted and  $p_d$  is the power dissipated per unit length. In general these parameters are functions of distance along the section. ( $\alpha_t$ , which has already been defined in connection with BPM delay lines is the reciprocal of  $T_o$ ). Since linear dimensions vary in inverse proportion to frequency  $f$ , we infer from the above definitions that for the same group velocity and same mode

$$s \propto f^2 \quad \text{and} \quad T_o \propto f^{-3/2} \quad (11)$$

For a structure of a given material  $\eta_s$  depends only on  $T_f$ .  $\eta_{pc}$  depends on  $T_f$  and on the compression factor  $C_f = T_k/T_f$ , where  $T_k$  is the klystron pulse length.

For a given  $T_o$ , both  $\eta_s$  and the product  $\eta_s T_f$  in Eq. (7) are functions of  $T_f$  only. The product  $\eta_s T_f$  as a function of  $T_f$  starts at zero and reaches a broad maximum when  $T_f = 1.257T_o$ , while  $\eta_s$  starts at unity and decreases as  $T_f$  increases. Therefore for a given gradient, section length, and  $T_o$ , with no pulse compression, both peak and average powers depend on section fill time only. The average power decreases and approaches a minimum and the peak power increases as we decrease the fill time from its value where the peak power has a broad minimum. This is illustrated in Fig. 6 which shows plots of peak and average powers per klystron (one klystron feeds 4 sections) required to produce a 21 MV/m gradient for a disk-loaded section having SLAC section parameters of  $s = 76.4$ ,  $T_o = 1.44\mu s$ ,  $L = 3m$  but allowing  $T_f$  and  $v_g$  to vary. The plotted points correspond to the SLAC section  $T_f = 0.82$ . Pulse compression reduces klystron peak power and, if we can compress with nearly 100% efficiency, also average power.



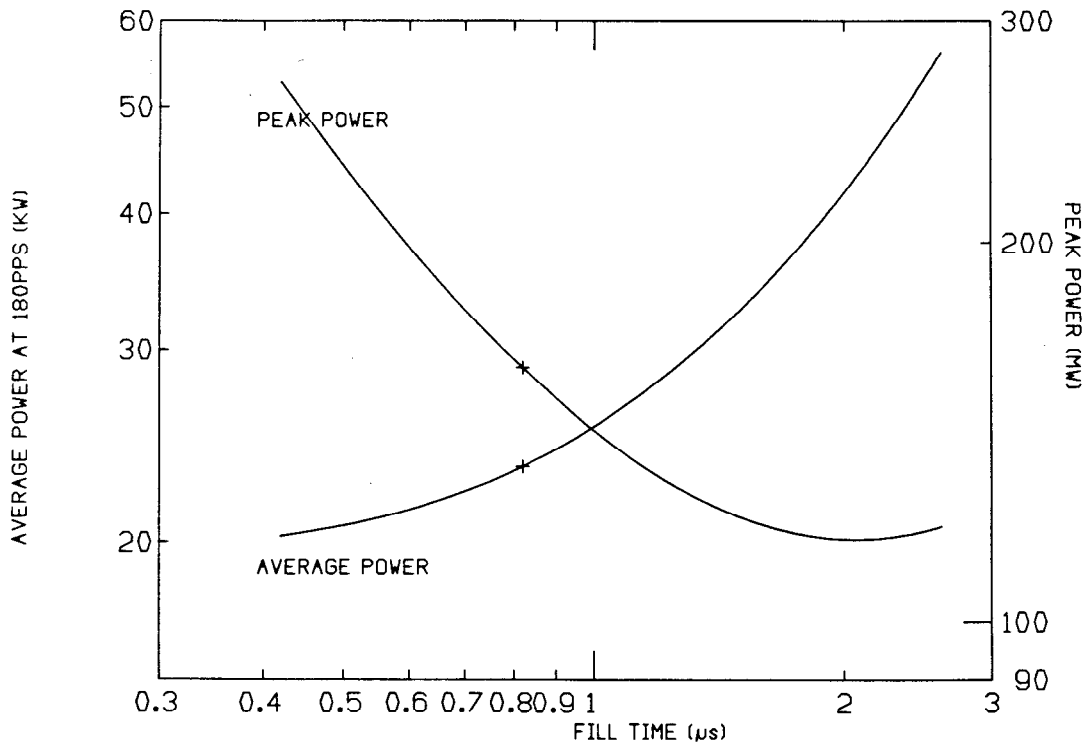

4-86

5195A13

Figure 6. Average and peak powers per section vs fill time.

The modulator line power  $P_m$ , is the klystron average rf power  $P_{ak}$  divided by the klystron efficiency  $\eta_k$ .

$$P_m = \frac{P_{ak}}{\eta_k} \quad , \quad \eta_k = \frac{0.398T_k}{(T_k + 1)} \quad , \quad T_k \text{ in } \mu\text{s} \quad . \quad (12)$$

The above expression for the klystron efficiency is based on measurements at SLAC, but is generally correct. It is the product of the klystron beam to rf efficiency, about 0.5, the modulator efficiency, about 0.8 and the efficiency due to beam pulse rise time,  $T_k/(T_k + 1)$ . If we do not consider any other ac losses, such as klystron focus coil power or refrigerator power when superconducting, then the ac to rf conversion efficiency is  $\eta_{ar} = \eta_k$ .

Using the above expressions we obtain the power requirements of several systems to drive the SLAC Linear Collider. Because of practical considerations such as loss in the arcs, the required beam energy is 66 GeV rather than the 50 GeV center of mass design energy and the required gradient  $E_a = 21$  MV/m. The following parameters are used:  $s = 76.4$  V/pC-m,  $T_f = 0.82 \mu\text{s}$ ,  $L_s = 3m$   $\eta_t = 0.891$  . There are 240 klystrons, each klystron drives 4 sections. A  $f_r = 180$  pulses per second is assumed. The values are listed in Table 1.

The first line of Table 1 is the system presently used at SLAC and is the benchmark design to which the other systems will be compared. The second line of Table 1 shows that with no pulse compression the rf efficiency increases, but because the ac to rf efficiency is reduced, the improvement in ac efficiency is not significant. Moreover, with no pulse compression, there is no option of also operating with a long beam pulse. There is even a better reason why SLAC uses pulse compression: 159 MW klystrons do not exist. The systems with 1, 2 and 3 stage BPMs require, respectively, 7, 11 and 15 MW less ac power. They save klystron average power as well, and because the klystrons are average power limited they enable higher pulse repetition rates. The last line in Table 1 is a 3 stage BPM with a compressed pulse equal to a shorter fill time of  $0.41 \mu\text{s}$ . It illustrates that for a given klystron pulse length the advantage of BPM over

Table 1. Systems to obtain 21 MV/m gradient at SLAC

SYSTEM	$M$	$\eta_{pc}$	$\eta_{rf}$	$U_k$ VA	$T_k$ $\mu s$	$P_{pk}$ MW	$P_{ak}$ kW	$\eta_{ar}$	$P_m$ kW	$P_{act}$ MW
NO PC	1	1	.532	130	.82	159	23.4	.179	131	31.5
SLED	3.18	.52	.277	250	5.0	50	45.1	.332	136	32.5
1 STAGE BPM	1.8	.9	.532	145	1.64	88.3	26.1	.247	105	25.3
2 STAGE BPM	3.18	.8	.426	163	3.28	50	29.3	.331	88.4	21.2
3 STAGE BPM	6.4	.8	.543	127	3.28	39	23.0	.331	69.0	16.6

$(T_f = 0.41 \mu s)$

SLED becomes more pronounced as the compressed pulse gets shorter. The listed compression efficiencies assume a 6 in diameter  $TE_{11}$  delay lines.

## ACCELERATOR DESIGN USING BPM WITH SUPERCONDUCTING DELAY LINES

With SLED we can nearly eliminate the reduction in efficiency due to dissipation loss by making the internal time constant of the energy storing cavities large compared with the pulse length. But we cannot eliminate the reduction in efficiency due to reflections and due to the exponential pulse shape. Moreover, the compression efficiency drops off rapidly as we deviate from a compression factor of about 3. In contrast with low attenuation delay line the BPM compression efficiency is essentially 100%. We can make the attenuation effectively zero even for long pulses by making the delay line out of superconducting material.

But in calculating the ac to rf conversion efficiency we must include the power required by the refrigerator,

$$P_{rd} = \frac{2\alpha_t T_d R_f}{I_f} P_{ak}$$

Here,  $\alpha_t$  the attenuation per  $\mu s$  of a copper delay line,  $T_d$  is the total time delay,

$R_f$  is the refrigeration factor,  $I_f$  is the improvement factor.<sup>9</sup> The total ac power is

$$P_{ac} = P_m + P_{rd} = P_m \left( 1 + \frac{2\alpha_t T_d R_f \eta_k}{I_f} \right) \quad (13)$$

The ac to rf conversion efficiency when refrigerator power is taken into account is

$$\eta_{ar} = \frac{P_{ak}}{P_{ac}} = \frac{\eta_k}{1 + \frac{2\alpha_t T_d R_f \eta_k}{I_f}} \quad (14)$$

Two systems, one with a two stage and the other with a 3 stage BPM, both using superconducting delay lines are illustrated in Table 2. We assume lead or niobium delay lines at 4.2°K with  $R_f = 1000$ ,  $I_f = 4000$ . We have obtained under various experimental conditions fields which would correspond to gigawatt delay line power levels.<sup>9</sup> Work being done in Europe to coat niobium and niobium-tin on copper. If successful it will make the use of superconducting delay lines even more attractive.

Table 2. System to obtain 21 MV/m gradient at SLAC  
using superconducting delay lines

SYSTEM	$M$	$\eta_{rf}$	$U_k$ VA	$T_k$ $\mu s$	$P_{pk}$ MW	$P_{ak}$ kW	$\eta_{ar}$	$P_m$ kW	$P_r$ kW	$P_{ac}$ kW	$P_{act}$ MW
2 STAGE BPM	4	.532	130	3.28	39.8	23.4	.318	70.6	3.32	74	17.8
3 STAGE BPM	8	.532	130	6.56	19.9	23.4	.312	67.7	7.73	75.4	18.1

The BPM with superconducting delay lines requires about 14 MW less AC power than the benchmark system of Table 1. Also, it halves klystron average power and consequently the pulse repetition rate can be doubled. Finally, it enables 0.82 or 1.6  $\mu s$  beam pulse operation at a reduced gradient of 15 MV/m. With 70 MW–3.28  $\mu s$  klystrons we reach 28 MV/m, a 84 GV beam. With 50 MW–6.56  $\mu s$  klystrons we reach 33 MV/m, a 100 GV beam with a moderate

incremental refrigeration cost and an additional 13 MW of ac power. This is moderate compared to the alternative of adding 360 klystron-modulators and 48 MW of ac power.

## THE BPM AT HIGH FREQUENCIES

For the same group velocity and section efficiency the elastance per unit length varies as the frequency squared and therefore the peak and average powers vary as the wavelength squared. Thus increasing the accelerator operating frequency reduces both peak and average powers. The attenuation per unit time delay varies as the  $3/2$  power of the wavelength. Therefore, to maintain the section efficiency, increasing the frequency by a factor  $r$  requires a decrease in the fill time by  $r^{3/2}$ . Table 3 lists the system parameters at 4 and 10 times the SLAC frequency.

Table 3. Systems to obtain 21 MV/m gradient

$f = 11424$ MHz										
Same	$v_g$ $m/\mu s$	$a$ cm	$L_s$ m	$s$ V/pC-m	$U_k$ VA	$T_k$ $\mu s$	$P_{pk}$ MW	$P_{ak}$ kW	$p_{pk}$ MW/m	$p_{ak}$ kW/m
$v_g$	3.50	.290	.36	1222	.224	.102	2.19	.040	6.08	.111
L	29.4	.494	3	831	2.45	.092	26.7	.444	8.9	.148
$a$	90.0	1.16	9.84	267	26.0	.070	371	1.82	37.7	.185
$f = 28560$ MHz										
$v_g$	3.50	.116	.095	76400	.009	.026	.359	.001	3.75	.011

We retain the section attenuation and consequently the fill time  $T_f = 0.82/8 = 0.1025 \mu s$ . We can change the fill time by either changing length, or group velocity or both. The first line retains the group velocity, the second the length and the third the aperture radius  $a$  of the 2856 MHz SLAC accelerator section.

If we keep the group velocity both average and peak powers decrease by  $r^2$ . The undesired consequences are very short sections and a factor  $r$  reduction in aperture size. If we keep the length then the group velocity decreases by  $r$ . If  $s$  were independent of  $v_g$  then it would increase by  $r^2$ , the peak power would be reduced by  $r$  and the average power by  $r^2$ . But  $s$  decreases as  $v_g$  increases and therefore the reduction in peak and average power is less than indicated above. The local section parameters were obtained using the computer code URMEL<sup>7</sup>. Because as the group velocity approaches the particle velocity the section need not be completely filled when the particle is injected,  $T_k$  is less than  $T_f$  in lines 2 and 3. The SLC peak and average powers per unit length are 4.2 MW/m and 3.8 kW/m respectively. Although it is contemplated that high particle energy linear colliders will operate at much higher gradients than the 21 MV/m SLC gradient we retained it to facilitate comparison with the 2856 MHz parameters.

For the same accelerator section efficiency, increasing the frequency by  $r$  decreases  $\alpha_t$  by  $r^{-3/2}$ . As the delay line time delay is proportional to fill time it also decreases by  $r^{3/2}$ . But with the delay line we have the freedom to increase the diameter and also to operate in the  $TE_{01}$  mode way above cutoff where at high frequencies we can have negligible loss even with a small diameter pipe. Couplers operating in this mode are available. Thus in the millimeter wave region we can obtain nearly ideal peak power multiplication with a BPM using copper delay lines. For example at  $4 \times 2856 = 11424$  MHz the attenuation is 0.05 nepers/ $\mu s$ , as indicated in Fig. 6.

Increasing the frequency tenfold to 28560 MHz results in the parameters shown in the last line of Table 3. Because of the short length per feed we have one source feeding 10 sections. The power fed to each section can be transmitted via overmoded circular  $TE_{01}$  guide. The required multiplication factor is peak power divided by source peak power. Using a 100 kW 0.83  $\mu s$  source and a 5 stage BPM we obtain 21 MV/m gradient. The longest required time delay is 0.41  $\mu s$ . As 100 kW CW amplifiers are available at this frequency, and as noted previously, the BPM can transform CW power into a train of pulses, with 100

kW amplifiers, we can increase the pulse repetition rate to 30000 pps.

Using 3 meter sections and an average rf power of 3.36 kW/m, about the same as currently required to attain the 21 MV/m for the Stanford Linear Collider, and using the a 38 MW-1.6  $\mu$ s gyrokystron currently being developed<sup>10</sup> in conjunction with a four stage ( $\times 16$ ) BPM, we obtain a gradient of 100 MV/m. The gradients vs pulse length attainable with 30 MW power into a SLAC section scaled to 10 GHz,  $T_f = 0.125\mu s$ ,  $L = 0.46m$  with SLED and with the BPM are shown in Fig. 7.

While microwave frequencies were emphasized, the BPM can be implemented at any frequency (such as optical) where hybrids, delay lines, biphas modulators, and amplifiers are available.

A program to produce a prototype BPM at a wavelength of 2.6 cm is under way at SLAC. Experimental results should be available in the near future.

## ACKNOWLEDGEMENTS

The help of P. Wilson in preparing this note is gratefully acknowledged.

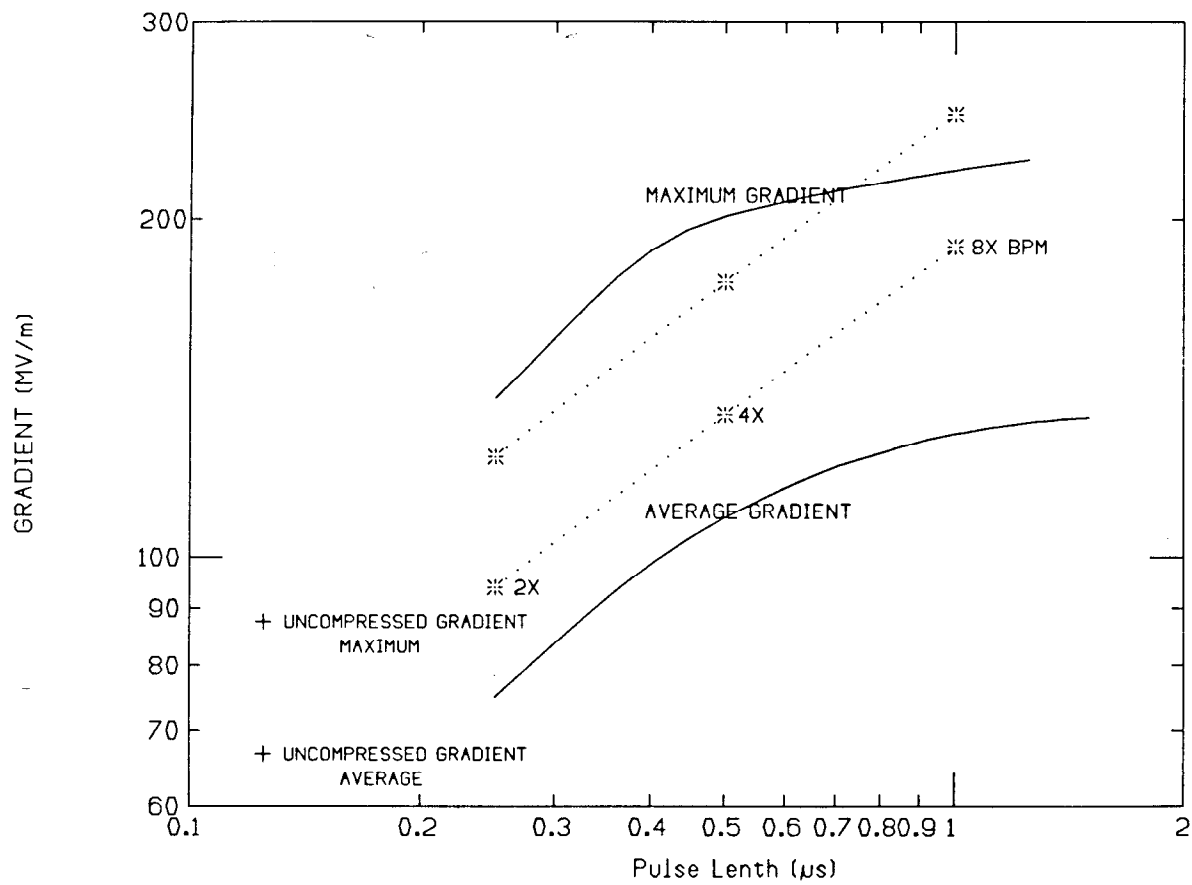

4-86

5195A12

Figure 7. Gradient vs pulse length.



## REFERENCES

1. B. Richter, "Very high energy colliders," IEEE Transactions of Nuclear Science, NS-32, p. 3828, October 1985.
2. S. Ecklund, "The Status of the Stanford Linear Collider", IEEE Transactions of Nuclear Science, NS-32, p. 1592, October 1985.
3. "Report of the HEPAP subpanel on advanced accelerator R&D and the SSC," DOE/ER-0255, October 1985.
4. Z. D. Farkas et al., "SLED: A Method of Doubling SLAC's Energy," Proceedings of 9th International Conference on High Energy Accelerator, p. 576, May 1976.
5. Z. D. Farkas, "New Formulation for Linear Accelerator Design", IEEE Transactions of Nuclear Science, NS-32, p. 2738, October 1985.
6. P. B. Wilson "High Energy Electron Linacs", February 1982, SLAC-PUB-2824
7. T. Weiland and J. Tueckmantel, "URMEL, Long Range forces in the Frequency Domain," DESY M82-07.
8. R.H. Helm, "Computation of the Properties of Traveling-Wave Linac Structures," Proc. of the 1970 Proton Lin. Acc. Conf., Vol. 1, pp. 279-271.
9. I. E. Campisi and Z. D. Farkas, "The Pulsed RF Superconductivity Program at SLAC," *Presented at the second Workshop on RF Superconductivity*, CERN, Geneva, July 21-17, 1984, SLAC-PUB-3412, August 1984.
10. V. L. Granatstein et al., "A 30 MW Gyrokystron Amplifier Design for High Energy Linear Accelerators.", IEEE Transactions Plasma Science, October 1985.