

HARDWARE UPGRADE FOR KLYSTRONS IN THE SLC*

R. K. JOBE, M. J. BROWNE AND K. P. SLATTERY

Stanford Linear Accelerator Center
Stanford University, Stanford, California, 94305

ABSTRACT

The control and monitoring of the klystrons in the first third of the SLAC linear accelerator has been commissioned, and a program to complete installation by summer 1985 is in progress. A general overview of the new control system for SLAC klystrons is presented along with a detailed description of the Modulator Klystron Support Unit. The MKSU contains all the devices necessary to interface klystron monitoring and control to the SLC control system through a dedicated intelligent CAMAC module. Controlled devices include RF phase and drive controls, the high power modulator status, associated RF signals, waterflow and magnet controls.

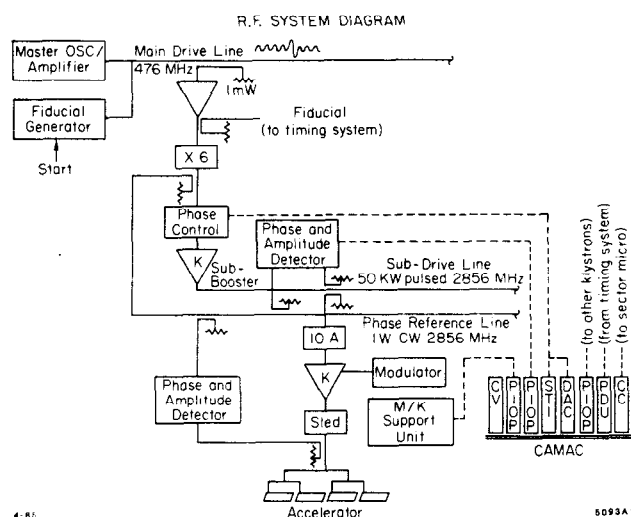

Fig. 1. RF system diagram: overview of control elements for linac sub-booster and klystron.

1. INTRODUCTION

SLC requirements for control and monitoring of the stability and phase of the RF sources at SLAC presented the following three new requirements:

1. Accurate phase measurements and reliable phase control of accelerator klystrons.
2. Immediate (same pulse) input to fast feedback systems of deficient RF pulses.
3. More flexible triggering, control and monitoring of klystron station.

The challenges presented above were met with the design and construction of the following devices:

1. PIOP - Parallel Input Output Processor. A microprocessor based CAMAC module which is programmed to support a klystron's operation.

* Work supported by the Department of Energy, contract DE-AC03-76SF00515.

2. PAD - Phase and Amplitude Detector. Responsible for phase and amplitude monitoring of the klystron's output. Consists of a local phase shifter, nulling detector, and amplitude monitor. The PAD is controlled by the PIOP through a digital link.
3. MKSU - Modulator Klystron Support Unit. A local hardware interface which contains all the digital and analog interface and monitoring circuitry to monitor and control, and trigger a single klystron station.

Ten sectors of PIOP's and PAD's were installed with a primitive version of the MKSU in the fall of 1984 to support operations in the phase monitoring and control aspects of klystron operation. By Fall of 1985, all 30 sectors of the SLAC Linac will be controlled by the final MKSU, PAD and PIOP. This paper describes the specific system support for the MKSU.

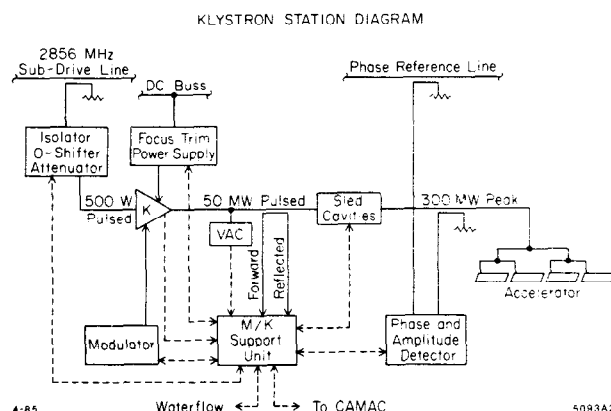

Fig. 2. Klystron station support: Simplified schematic.

2. MKSU

The MKSU is the local hardware interface for klystron control at the SLAC linear accelerator. Replacing another module (the Modulator Klystron Protection Unit) the MKSU provides a complete interface to the new control system of the status of a klystron station. The MKSU is a rack mounted chassis which is located in the flat rack adjacent to the controlled klystron. The CAMAC interface (the PIOP) may be up to a hundred feet away. The MKSU contains:

1. An open frame chassis containing a power supply, rear panel connectors wired to internal PC edge connectors, and an internal data buss with PC edge connectors. Contains the relay protection logic for "hard" interlock protection.
2. Buss Interface Board - interfaces the local buss to the PIOP, drives the front panel board, and generates modulator triggers.
3. Front Panel Board - an array of LED's, eight push buttons, and a trigger output for oscilloscope triggering.

4. PAD Interface Board - interfaces to the local Phase and Amplitude Detector.
5. Digital Board - opto-isolators and digital drivers to receive and transmit digital controls. Board contains a DAC to provide the current source for the high power attenuator, and drives the phase shifter stepping motor.
6. Analog Board - the ADC for all analog monitoring, as well as the sample and hold and peak holding circuitry for monitoring of video signals.
7. Monitor Board - contains additional analog inputs readable through the analog board, DAC's to control the focus magnet and a spare output, and additional digital inputs.

3. SIGNALS

The signals and controls for klystrons at SLAC were substantially defined and provided by existing hardware. The design criterion was to use the existing signal sources and cable plant wherever practical. All signals can be remotely monitored by the control system, and viewed from the SCP control program.

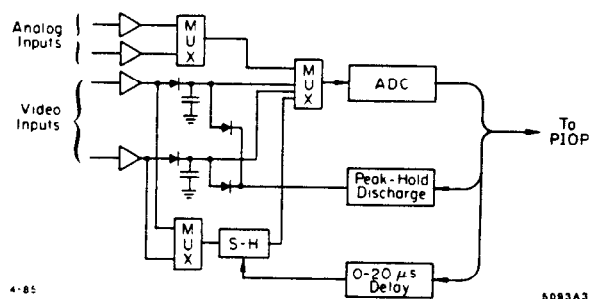

Fig. 3. Analog signal processing.

Signal Types -

1. Digital - protection and status signals such as waterflow switches, motor controls, and modulator status.
2. Analog - protection and diagnostic signals such as temperature rise, klystron heater power, magnet current and attenuator control.
3. Video - Beam Voltage and Current, Forward, Reflected, and Drive RF are monitored for peak value on each pulse, and are available for Fast Time Plot diagnostics.
4. Triggers - Fast Time Plot and Modulator triggers. Delays for each trigger are under software control.

Signal Uses -

1. Hard Interlocks - Waterflow, Waveguide Vacuum, Electro-Magnet, and SLED cavity status form a relay based trigger protection system. Software in the PIOP can monitor and record faults to provide the operator with information concerning the nature of the individual faults.
2. Soft Interlocks - Peak Reflected RF, Klystron Temperature, Peak Beam Volts and Current and Klystron Vacuum Status are monitored by the PIOP. If any of these signals exceed their DataBase limits, the PIOP's program will inhibit triggering the modulator for a second or longer.

3. Monitoring Only - Modulator Status, Waveguide and Klystron Vacuum Pressure and RF Drive are among the signals which are monitored to allow remote diagnostics of any detected problem and to allow fault recording.

4. CONTROL SUPPORT - PAD

The MKSU system monitors and controls the RF entering the accelerator, allowing operators to record phase information describing the current machine operations, and to set the phase to a previously recorded value. This feature allows speedy recovery from interfering maintenance operations such as a klystron replacement. The monitoring and control are accomplished primarily through:

1. PAD - The phase and amplitude simultaneously measures the magnitude and phase of the RF pulse that each klystron station provides the accelerator.
2. IPA - The Isolator, Phase shifter, and Attenuator is a high power RF controller consisting of: a rotary field continuous phase shifter, a solid state PIN diode attenuator, and an RF voltage detector. The MKSU drives the stepping motor for the phase shifter, and provides a programmed current source for the attenuator. The RF detector supplies both a front panel diagnostic monitor and the MKSU with a video signal, allowing remote monitoring of the drive pulse.

5. PROTECTION

The MKSU is the primary klystron protection against any RF or hardware fault. The protection signals have been divided into two categories: those which either by the virtue of their nature or importance are considered to be a vital component of klystron protection (the "hard" interlocks), and those which are not critical to the protection, and which are not likely to be accidentally generated due to a software "bug" in the control system software (the "soft" interlocks).

The list of hard and soft interlock signals can be found in the section on "signals". Since the new SLAC 5045 high power klystron is a relatively young klystron, the list of "soft" interlock signals and the response to soft faults are likely to change as more experience running the klystron is acquired.

6. TRIGGERING

Triggers for the klystron modulator are generated by the buss interface board in the MKSU. Timing signals are generated by a Programmable Delay Unit (PDU) and received by the PIOP in the CAMAC crate. Triggers are sent to the MKSU over the 18 pair data cable from the PIOP, and delayed in the MKSU by a programmable delay counter. The range of trigger delays is 0-7.5 microseconds, in 34 nanosecond steps. The trigger is delayed to allow compensation for thyrotron triggering, cable length, and to allow maintenance personnel to locally adjust the delay as an aid in turning on the klystron station.

Triggering is enabled both through the PIOP's program control, and through the relay interlock chain in the MKSU.

7. DIAGNOSTICS

The MKSU chassis includes a front panel control which is designed to allow maintenance personnel to quickly commission a klystron station. Commissioning of a klystron station may be accomplished either of the following ways: a) Existing controls through a local "calf" console to adjust klystron parameters through the the SCP control program, or b) through the use

of local front panel controls. Experience suggests that local controls allow a speedier commissioning cycle for RF processing of new stations.

The local controls are disabled while the klystron station is "online" and used by operations. A station may only be placed in "maintenance" mode through the SCP control program. While in maintenance mode, the klystron may not be used to accelerate a beam. The local controls are:

1. Local/Remote - allows operation of station via local controls. station must already be in "maintenance" mode.
2. Drive - control of high power attenuator.
3. Delay - triggering delay. Allows station to be delayed sufficiently so that RF drive pulse and beam voltage pulse no longer overlap.
4. Rate - Base trigger rate. Rates are adjustable in steps of 10 Hertz.

REFERENCES

1. K. Thompson, "Timing System Control Software in the SLC," Proceedings of this conference.
2. R. K. Jobe, "A New Control System for the Accelerator Klystrons for SLC," IEEE Trans. on Nucl. Sci. NS-30, No. 4, August 1983.
3. J. D. Fox and H. D. Schwartz, "Phase and Amplitude Detection System for the Stanford Linear Accelerator," IEEE Trans. on Nucl. Sci. NS-30, No. 4, August 1983.
4. H. D. Schwartz, "Computer Control of RF at SLAC," Proceedings of this conference.