

**A PRECISION MASTER TRIGGER SYSTEM FOR SLC BASED  
 ON THE ACCELERATOR RF DRIVE SYSTEM\***

R. F. KOONTZ, G. LEGER, L. PAFFRATH, A. WILMUNDER  
 Stanford Linear Accelerator Center  
 Stanford University, Stanford, California 94305

**Summary**

A new trigger system consisting of a single 476 MHz rf doublet pulse superimposed on the main 476 MHz rf Drive Line signal that transmits the 3 km accelerator has been implemented and is working well. This paper describes the general concept of this system, outlines the operation of the main master trigger generator, the fiducial (476 MHz doublet) generator, and the fiducial pickoff system. A companion paper by Paffrath et al describes the counter electronics that produces precision timed triggers for all SLC operations along the accelerator.

**Introduction**

At SLAC, the most stable conduit for transmitting precision time signals the length of the accelerator is the temperature controlled main rf drive line. When the storage rings, PEP and SPEAR, require precisely timed electron and positron bursts to match ring buckets, the bucket requests are matrixed onto the main drive line at the end of the accelerator, and picked off at the injector for gun triggers. Keying frequencies from both PEP and SPEAR synchronize accelerator klystron firing times to match ring bucket request times.

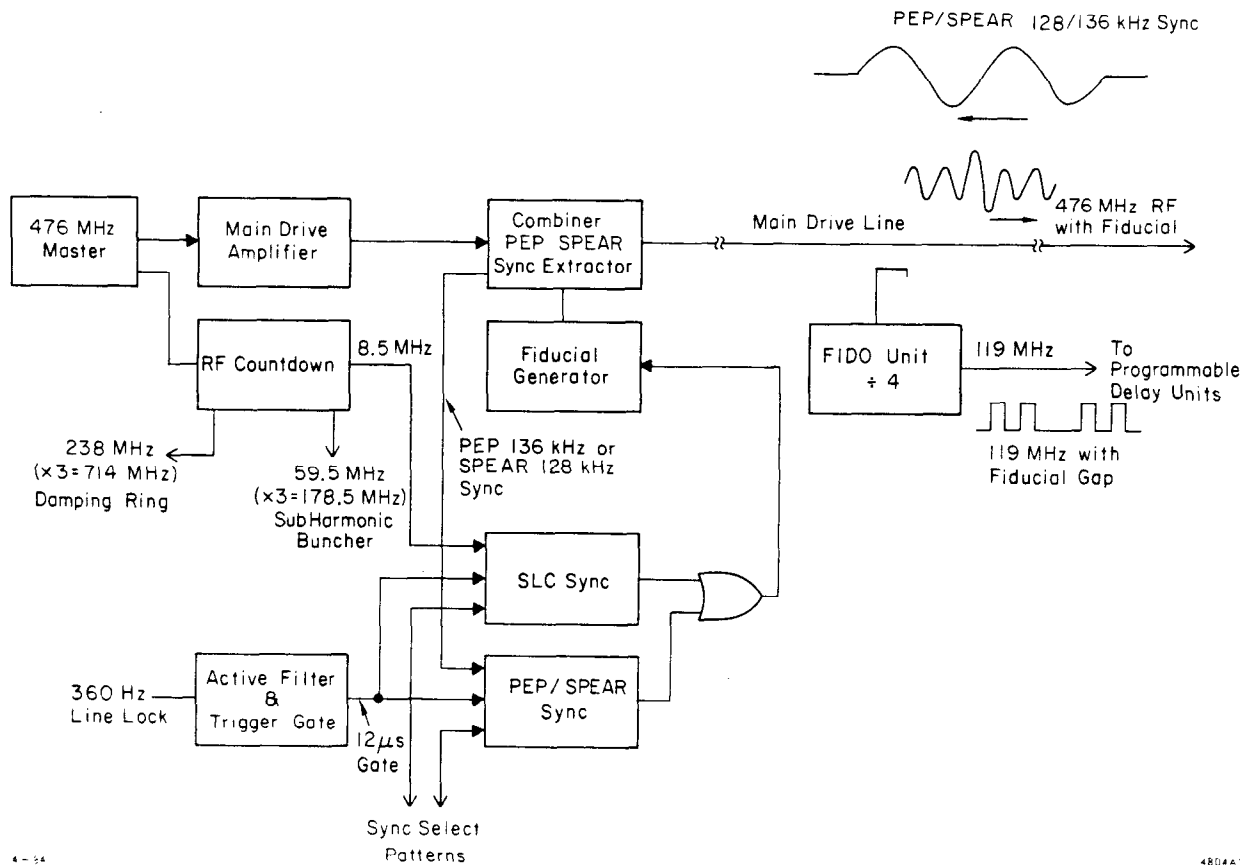

Fig. 1. Block Diagram of the driveline based trigger system.

\* Work supported by the Department of Energy, contract DE-AC03-76SF00515

The accelerator also contains a main trigger line, but temperature variations, and line dispersion limit the triggering stability along the accelerator to about 10 nsec. The main drive line is stable to better than  $20^\circ$  of phase at 2856 MHz, and that translates into an intrinsic time stability of about 20 psec. Clearly, it is useful to use the main drive line as a conduit for a precision trigger system.

Triggers are needed at different times, and a frequency counting delay system gives the most precise trigger delay based only on the stability of the oscillator being counted. The rf drive of the accelerator is generated by a stable cavity oscillator phase locked to a precision crystal. A time delay counter system based on this frequency can give stable delays counted from a fiducial time pulse that is phase locked to the accelerator rf. Hence, the idea of superimposing a phase locked 2 nsec high level doublet pulse on the 476 MHz accelerator rf drive frequency was born. The existing accelerator trigger system makes use of a  $t=1000 \mu\text{sec}$  trigger for early pretrigger functions, and a  $t=2.5 \mu\text{sec}$  trigger for beamtime functions. The time of the new fiducial pulse was chosen to coincide with the  $t=1000 \mu\text{sec}$  pretrigger pulse so that the old and new systems could coexist while the transition from old to new is made.

### The Trigger System

Figure 1 is a block diagram of the driveline based trigger system. The master oscillator frequency, 476 MHz, is the sixth sub-harmonic of the main klystron rf drive frequency, 2856 MHz. This precision, low noise cw frequency source is amplified to 60 W and combined in a hybrid with a special 2 nsec doublet pulse from the fiducial generator. Fiducial timing is determined as follows: Some of the 476 MHz from the master oscillator is counted down in a series of phase locked ECL dividers to 8.5 MHz, the going-around frequency of the SLC damping rings. Subharmonics are picked off at 238 MHz, and 59.5 MHz. The 238 MHz is multiplied by 3 to 714 MHz to form the damping ring klystron drive frequency. The 59.5 MHz is multiplied by 3 to produce the 178.5 MHz CID injector sub-harmonic bunchers drive frequency. It is important to lock the basic accelerator trigger rate to a harmonic of the power line frequency so that ripple and hum modulation do not beat with the PRF. A 360 Hz line derived sine wave is narrow band filtered to produce a train of regular spaced gate pulses at 360 Hz zero crossings. These gate pulses are used to select either one of the zero crossings of the 8.5 MHz derived from the master oscillator, or a zero crossing of a PEP or SPEAR synchronization frequency burst delivered to the master trigger generator from PEP or SPEAR via the main drive line. The synchronization used is determined by the beam pattern gates. The trigger thus derived is delivered to the fiducial generator where a final synchronization is made to the 476 MHz drive line frequency. The combination of the fiducial doublet pulse and the 476 MHz cw reference frequency is shown in fig. 2.

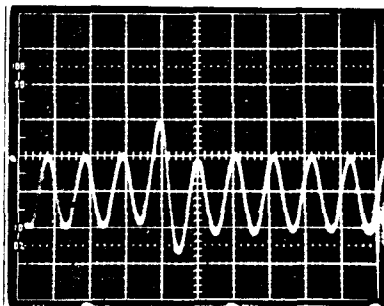

Fig. 2. Fiducial on 476 MHz (2 nsec/cm).

This signal transmits the main drive line, and is coupled out at each sector to provide both the reference rf for the times 6 multipliers that supply the 2856 MHz rf drive to the sub-boosters, and the timing fiducial that is used by the Programmable Delay Units (PDU) that provide klystron and other precision beam related triggers.

### Fiducial Generator

The main fiducial generator is shown in block diagram form in fig 3. The trigger derived from the master trigger generator is synchronized to the 476 MHz drive frequency and phase adjusted so that the output of the avalanche doublet pulser adds to one of the cycles of the 476 MHz sine wave. The avalanche pulser is of special note. The intrinsic delay through the series of avalanche breakdown transistors is used to first deliver a positive pulse from the emitter of the bottom transistor to one winding of the pulse forming network, and then about a nanosecond later when the collector of the last avalanche transistor falls, a negative pulse is delivered to the opposite winding to cancel the first pulse. A fast doublet pulse results with peak-to-peak magnitude in excess of 400 V into a  $50 \Omega$  load. When this is combined in the hybrids as shown, the main drive line fiducial pulse results.

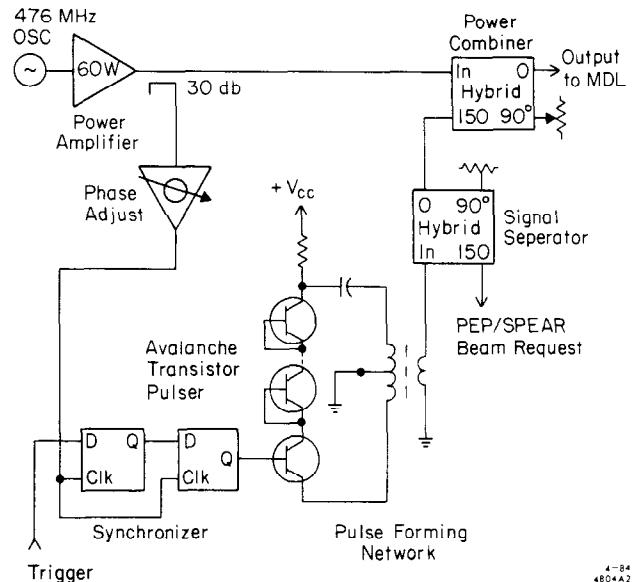

Fig. 3. Fiducial generator.

### Fiducial Pickoff Amplifiers

Figure 4 shows a block diagram of the fiducial pickoff system used at each sector of the accelerator. The normal drive line coupler supplies 20 mW of 476 MHz rf to a wideband solid state amplifier the main output of which drives the times 6 multipliers. Part of the amplifier output is routed to a fiducial detector and countdown device called a FIDO. The output of the FIDO is a 119 MHz ECL square wave that has a cycle missing at fiducial time. The PDU's start counting this 119 MHz square wave on detection of the missing cycle, and count out the programmed time interval to produce the requisite trigger pulses. The operation of the FIDO and PDU are discussed in the companion paper by Paffrath et al.

The proof of any system is in the operation. Although the whole new trigger system is not operational for the full 3 km

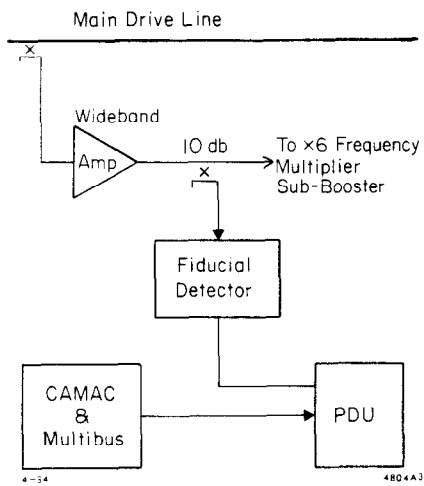

Fig. 4. Fiducial pickoff.

of the accelerator, initial tests that compare a single bunch reference electron beam to a trigger generated by the new fiducial system show an intrinsic stability of the whole system of better than 200 psec. The full 3 km of this new trigger system will be operational by January of 1985, and further modifications to the primary trigger generation system are planned to meet SLC operational needs.