

R. F. Koontz
Stanford Linear Accelerator Center
Stanford University, Stanford, California 94305

ABSTRACT

A new high-current thermionic gun has been installed on the CID injector at SLAC and brought into operation. The gun and pulser system generate three nano-second pulses of about six amps peak which, when bunched in the subharmonic buncher system, produce in excess of 10^{11} electrons in a single S-band accelerated bunch. Preliminary operation of the gun is described, and details of the avalanche cathode drive pulser are presented.

INTRODUCTION

The Collider Injector (CID) has operated successfully accelerating 10^{11} electrons in a single S band bunch to 35 MeV. The electron source used for this injector is a thermionic grided gun driven by an avalanche transistor pulser first described in Ref. 1. We have now completed detailed testing of this gun and pulser system, and the results are presented here. Figure 1 shows a cross section of the gun.

GUN DEVELOPMENT

The CID thermionic gun makes use of a special cathode-grid structure developed for us by EIMAC in Salt Lake City.² (Fig. 2). The structure is

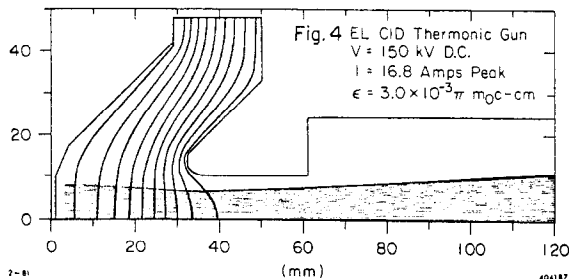
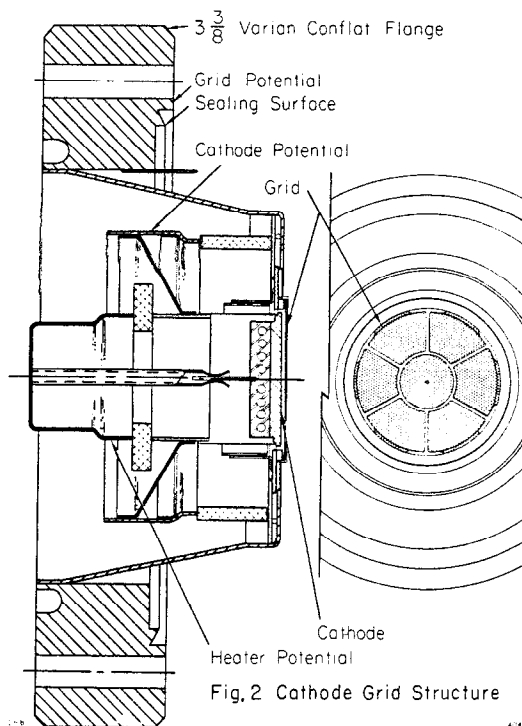
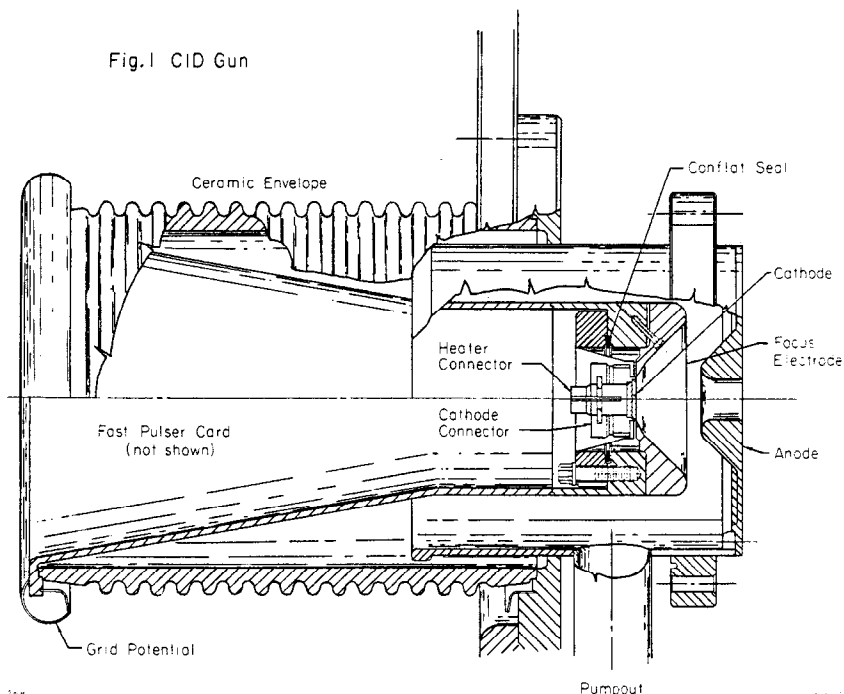

Fig. 1 CID Gun



* Work supported by the Department of Energy, contract DE-AC03-76SF00515.

mounted on a 3 3/8" Varian Conflat vacuum flange which allows easy replacement of the cathode without demounting or disassembling the gun envelope. The cathode is of the dispenser type which can be let up to air. The emission characteristics as a function of brightness and filament power are shown in Fig. 3. The gun electrode geometry was modeled using the electron trajectory program of W. B. Herrmannsfeldt.³ Figure 4 shows a computer plot of the gun optics at 150 kV. The code predicts a perveance of 0.29 microperv. Figure 5 shows the measured gun characteristics. The average measured perveance is 0.27 microperv. A bias

PULSER DEVELOPMENT

Figure 6 shows a block diagram of the avalanche type pulser developed initially for the CID gun. There was no power source other than filament power available on the gun back deck, so all power for the pulser was derived from the filament source. The pulser trigger is coupled to the high voltage gun deck through a ballun type transformer.⁴ The pulser system itself consists of four, three transistor avalanche pulsers driving 50 ohm coaxial inversion transformers. The four transformers drive the gun cathode-grid gap and deliver a combined peak current of about

9 amps in a 2.5 nanosecond pulse. With grid interception and other losses, this yields an anode beam pulse of 6 to 7 amps fully contained baseline to baseline in 3 nanoseconds. The whole pulser and power supply system resides within the conical re-entrant portion of the gun body. Figure 7 shows a photograph of the gun with the pulser in place.

REFERENCES

1. R. Koontz, R. Miller, T. McKinney, and A. Wilmunder, "SLAC Collider Injector, RF Drive Synchronization and Trigger Electronics and

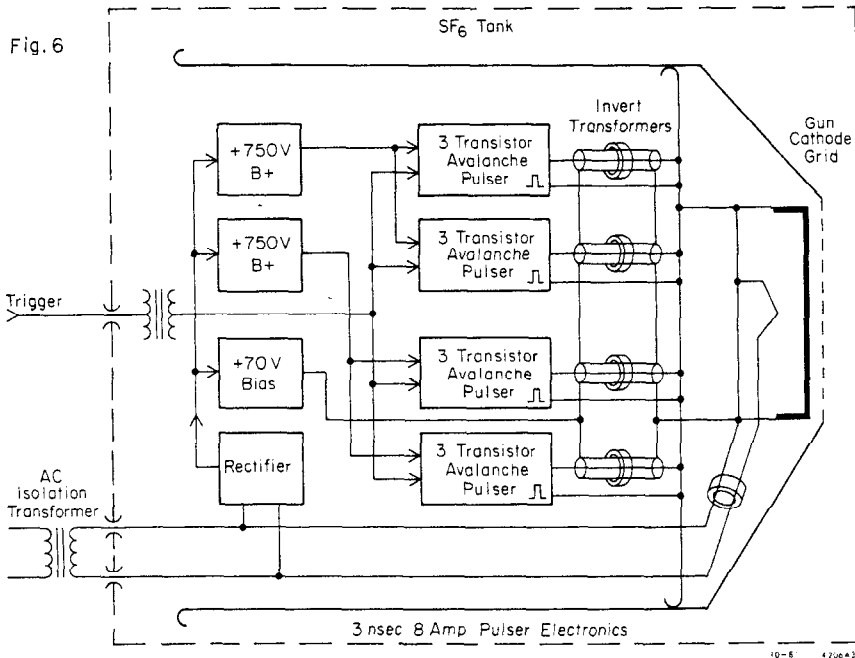

of -60 volts cuts the gun off at 200 kV anode voltage, and a peak pulse drive of +280 volts produces an anode current of 20 amps. Grid interception is about 28%, and the cathode drive active impedance approximates 12 ohms. Rise and fall times of the anode beam pulse have been measured at less than 200 picoseconds.

The first CID gun has been hi-potted to 200 kV in one atmosphere of SF₆, and has been beam tested to 175 kV. Emmittance has not been measured as yet, but the beam has been transported, subharmonically bunched, and accelerated to 35 MeV with little beam loss. The first cathode is still in place with close to 1,000 hours of operation, has been let up to air several times, and still shows no signs of degradation.

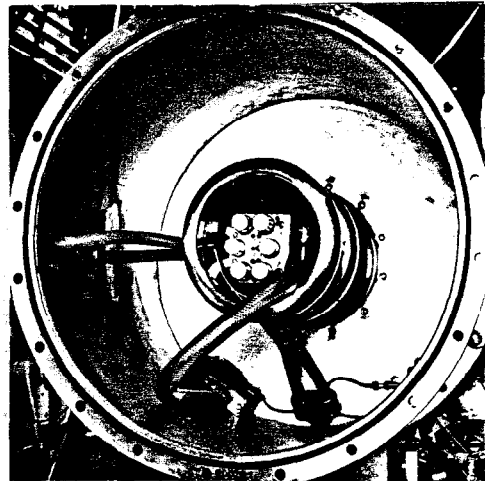

Fig. 7

15 Amp Thermionic Gun Development, "Proc. Particle Accelerator Conf., Washington, D. C., March 11-13, 1981 (June 1981) Vol. NS-28, No. 3, Part 1 .

2. EIMAC, Division of Varian, Salt Lake City, Utah 84104 (Werner Brunhart).

3. W. B. Herrmannsfeldt, "Electron Trajectory Program," SLAC-Report-226 (November 1979).

4. R. Koontz, "Single Bunch Beam Loading on the SLAC Two-Mile Accelerator," SLAC-Report-195, p. 169 (May 1976).

