

A HIGH CURRENT, SHORT PULSE, RF SYNCHRONIZED ELECTRON GUN  
FOR THE STANFORD LINEAR ACCELERATOR\*

Charles K. Sinclair and Roger H. Miller  
Stanford Linear Accelerator Center  
Stanford University, Stanford, CA 94305

Abstract

For the generation of intense single and multiple bunches of electrons ( $>8$  nc per bunch) for accelerator studies at SLAC, a high peak current photoemission electron gun has been developed. A gallium arsenide photocathode is illuminated by the optical beam from a frequency doubled, actively mode-locked and Q-switched Nd:YAG laser. The mode-locked optical pulses are of variable, sub-nanosecond width and occur with a spacing of 8.4 nsec, synchronized with the 2856 MHz accelerator rf. The gun is designed to be space charge limited at 15 A and 200 kV, although emission of 60 A was obtained with a 57 kV test structure, corresponding to a current density of  $180 \text{ A/cm}^2$ . With the proper choice of laser wavelength, the electron beam may be 40% longitudinally polarized.

Introduction

Photoemission from solids has rarely been employed as a source of electron beams. There are many reasons for this. Compared with thermionic or field emission sources, photoemitters require a considerably better vacuum to assure cathode longevity. The photocathode must be activated in situ with alkali metals. For the beam currents required in many applications, an intense light source (typically a laser) is required. Finally, the gun structure and beam line must allow an optically clear path to permit illumination of the cathode.

Each of these difficulties can be handled, however, and the unique characteristics of the photoemission process warrant its use in some specialized applications. These unique features include the generation of polarized electron beams; the ability to modulate the beam current (or even the position at the cathode) on a time scale impossible with current technology for thermionic or field emitters; the production of cathode current densities considerably greater than possible with thermionic emitters; and the improved emittance which results from the absence of a grid. In the following sections we will review our previous operational experience with photoemission electron guns, describe some tests we have done to measure the performance of these cathodes under intense short pulse illumination, and discuss the design and present status of our high current, short pulse gun development.

Previous Experience

For a parity violation experiment,<sup>1</sup> we developed a longitudinally polarized electron gun employing a negative electron affinity gallium arsenide (GaAs) photocathode. The negative electron affinity surface was prepared by in situ activation of a clean GaAs wafer with cesium and oxygen. The cathodes were normally operated at or near liquid nitrogen temperature (77K) to improve the beam polarization. Room temperature operation is much easier for applications where beam polarization is not required. While the operation of these guns was a more complex task than the operation of conventional linac guns, we were able to maintain 24 hour a day operation for periods of six weeks, with 93% beam availability. A very large fraction of the difficulties associated with the use of these guns came

\*Work supported by the Department of Energy, contract DE-AC03-76SF00515

from the low temperature operation of the cathodes, and from the details of the laser system used to illuminate the cathode. We believe that we will eliminate many of the problems in each of these areas in the second generation photoemission gun now under development.

Cathode lifetimes were a strong function of operating temperature. Room temperature cathodes appear to be limited by slow cesium desorption from the activated cathode surface. Such cathodes are easily restored to full performance by a brief addition of cesium. After several such re-cesiations, the cathode lifetimes typically become quite long. We have observed some cathode lifetimes longer than we could reasonably measure (i.e., no measured decrease in quantum efficiency over a period of several weeks). Low temperature cathodes are degraded by cryopumping of residual gases at the cathode surface. Operation with the surrounding surfaces at, or below, the cathode temperature limits degradation from this cause. Such cathodes last from one to several days in our guns, and can be restored by in situ heat cleaning and reactivation.

The GaAs disks we used for our cathodes were cut from slabs of commercially grown and polished bulk material. This material has a rather low minority carrier diffusion length, compared with carefully grown epitaxial material. As a result, the cathodes we prepare have a low quantum efficiency compared with the best performance GaAs photocathodes. We typically prepared cathodes with a few percent quantum efficiency. We regarded 8% as a very good result, and 1% as a poor performance.

Our guns delivered peak photocurrents of several hundred mA, and many tens of coulombs of integrated charge during their total use. We believe this good performance is due to the excellent vacuum we maintain in our guns ( $2$  to  $3 \times 10^{-11}$  torr) and to the fact that little or none of the beam strikes any surface in the vicinity of the cathode, causing a locally poor vacuum through desorption. These conditions are quite different from those in, for example, a GaAs photomultiplier, where the tube performance is significantly impaired after the delivery of far less integrated charge. On the basis of our experience, we believe that GaAs photocathodes can deliver very high peak currents and very large integrated charge, with no more than occasional re-cesiation required.

High Current, Short Pulse Cathode Tests

Theoretically, one expects that a GaAs photocathode should be capable of delivering emission current densities of hundreds of  $\text{A/cm}^2$ . The emitted current should follow the incident optical pulse shape down to a time scale approaching the optical absorption depth divided by the Fermi velocity at the bottom of the conduction band, i.e., into the picosecond regime. Thus, such cathodes should be capable of delivering very intense short bursts of longitudinally polarized electrons. By locking the optical pulses to the linac rf, the beam pulses will be delivered in a stable phase with respect to the accelerating field. The need for a source of single, high charge bunches for the proposed SLAC linear collider, coupled with the considerable physics desirability of having longitudinally polarized electron beams, led naturally to the consideration of a photoemission electron source. Before beginning a full-scale gun development program, we constructed a small test gun, designed only to show

that large currents and short pulse widths could be obtained with GaAs photocathodes.

The test gun was designed to deliver, at 50 kV, a 50 A space charge limited current from a 1 cm diameter cathode. The beam current was observed by a Faraday cup beam dump, and with a capacitively decoupled 1 ohm resistor in series with the cathode. The Faraday cup and its surrounding vacuum chamber were designed to be a 5 ohm coaxial line. This line was carefully terminated external to the vacuum system, allowing the time structure to be observed with a 400 MHz real time oscilloscope. The cup was calibrated by allowing the beam current to charge a known capacitor. An air core solenoid of up to  $2 \times 10^4$  amp-turns strength covered the region between the anode and the entrance to the Faraday cup. The short optical pulses were produced by rapidly pulsing a Pockels cell placed between crossed polarizers and located in the output of a frequency doubled Nd:YAG laser.

Test results with this gun showed a beam current of 60 A leaving the cathode, of which 30 A was detected in the Faraday cup, at a gun voltage of 57 kV. The electron beam pulse shape was observed to follow the optical pulse shape, as determined with a fast photodiode, into the 1.5 to 2 nsec regime, the fastest which could reliably be observed with our 400 MHz oscilloscope. The illuminated area for these measurements was 6 mm in diameter, giving a peak current of  $180 \text{ A/cm}^2$ , far greater than currents obtainable with conventional thermionic emitters. It is worth noting that these short pulses were obtained without the use of a grid.

The quantum efficiency of the cathode was measured with both a 2 mW He-Ne laser, and with an 80 kW pulse from the doubled Nd:YAG laser. Within the precision of these measurements (about 25%), the quantum efficiencies were the same, indicating that no limiting mechanism is occurring in the GaAs over a range of  $4 \times 10^7$  in incident optical power. With 57 kV on the gun, the field at the cathode was 80 kV/cm, demonstrating that cesiated cathodes can operate in these high fields without breakdown. No cathode deterioration was observed during the tests, although they were of far shorter duration than the actual running time accumulated on the cathodes used in the parity experiment.

#### Developmental High Current Gun

On the strength of the tests described above, we decided to develop a photoemission gun to deliver intense single (and multiple) bunches of charge ( $>7.5 \times 10^{10}$  electrons per bunch) to the SLAC linac for accelerator physics studies for the proposed linear collider. While our test results indicated that we could in principle construct a gun to deliver this charge in a time short enough to allow direct bunching at the S-band linac frequency, calculations indicated that space charge effects were too severe to be confident that we could succeed with such a program. As a consequence, we decided upon a subharmonic bunching scheme<sup>2</sup> and chose a bunching frequency low enough (178.5 MHz) to permit a high performance thermionic gun to be used as well. Such a gun is under development at SLAC.<sup>3</sup>

The photoemission gun as built is shown in figure 1. It employs an intermediate focus electrode which allows the gun to deliver a slightly convergent beam while maintaining a good emittance. The emittance is calculated to be  $1.0 \times 10^{-3} \text{ m}_0\text{c-cm}$ , using the SLAC Electron Trajectory Program.<sup>4</sup> The gun is designed to operate at 200 kV, and is insulated by atmospheric pressure SF<sub>6</sub>. The focus electrode is located to keep the field at the cathode to the 80 kV/cm we achieved in the test gun. The design is space charge limited at 15 A, and

employs a 2 cm diameter cathode. The anode to cathode spacing is too short to allow easy access for activation. Thus the cathode is mounted on a bellows assembly which allows it to be retracted for activation. The structure was baked once in the laboratory, and reached a pressure of  $2 \times 10^{-10}$  torr. The gun is currently installed on the subharmonic buncher section, and is undergoing its final vacuum bakeout.

The optical pulses for the gun are obtained by frequency doubling the output of an actively mode-locked and Q-switched Nd:YAG laser oscillator. This laser is a modified version of the oscillator used with the SHIVA and ARGUS fusion lasers at the Lawrence Livermore Laboratory.<sup>5</sup> Our modifications allow operation at higher repetition rates than necessary for the LLL use. The laser is actively mode-locked at 59.5 MHz, the 48th subharmonic of the 2856 MHz linac rf frequency. Output pulses are produced every 8.4 nsec, at each zero crossing of the 59.5 MHz. The optical pulse width can be varied between about 100 and 1300 psec by changing the laser bandwidth and the drive power to the mode-locking modulator. After frequency doubling (to 532 nm), single or multiple pulses can be delivered to the cathode with the aid of a Pockels cell switchout unit. The entire laser system is currently operational at 30 Hz repetition rate, and most components have been operated at over 100 Hz. We anticipate being able to operate at the 180 Hz linac repetition frequency with further work on this laser or a variant.

The 532 nm wavelength is not appropriate to operation with polarized beams. To obtain beam polarization, it is necessary to use a photon energy only slightly greater than the minimum bandgap energy, about 1.5 eV for GaAs. Various techniques, such as using the 532 nm pulses to pump a dye laser tuned to the proper wavelength, will be used in the future to generate polarized beams. Current efforts are directed to studying the behavior of intense single bunches in the linac structure, and the interaction of one intense bunch with another following some time later.

#### Acknowledgment

Dr. Dirk Kuizenga of the Lawrence Livermore Lab has provided a great deal of excellent help with the laser.

#### References

1. C. Y. Prescott et al., Phys. Lett. 77B, 347 (1978)
2. M. B. James and R. H. Miller, A High Current Injector for the Proposed SLAC Linear Collider, this conf.
3. R. F. Koontz, SLAC Collider Injector RF Drive, Synchronization, and Trigger Electronics, this conf.
4. W. B. Herrmannsfeldt, SLAC Report 226
5. D. J. Kuizenga, Opt. Comm. 22, 156 (1977)

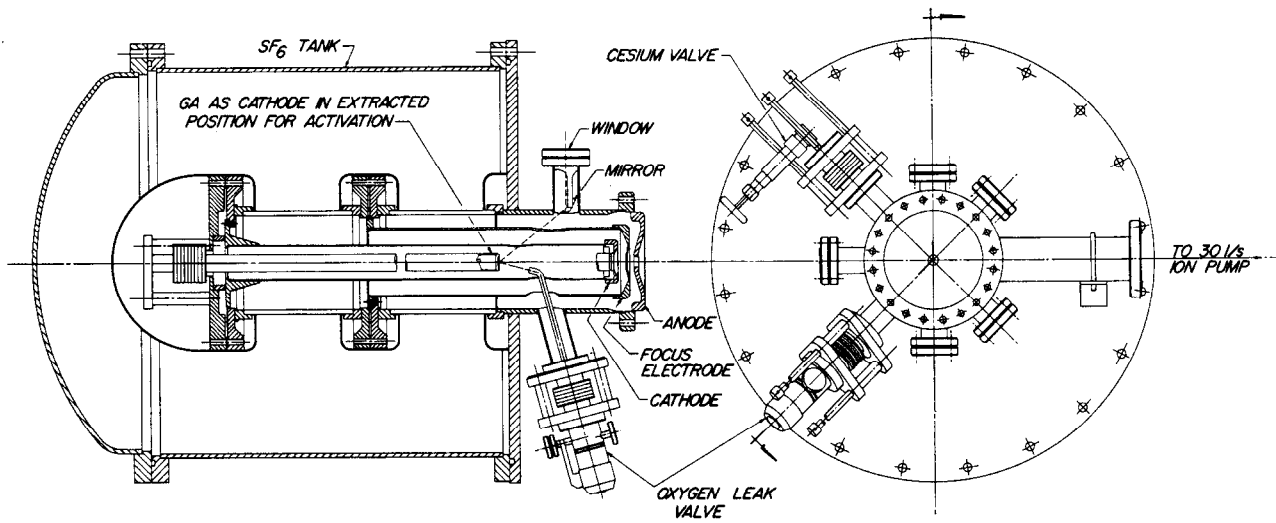

Figure 1. As-built view of the high current photoemission gun. The GaAs cathode is shown in the retracted position for activation. In operation, the cesium and oxygen systems are retracted, and the GaAs moved into the cathode electrode.