

A LUMINOSITY MONITOR AT PEP\*

J. D. Fox and M. E. B. Franklin  
 Stanford Linear Accelerator Center  
 Stanford University, Stanford, CA 94305

Abstract

The luminosity monitor system utilized by the MKII Detector and by the PEP operators is described. This system processes information from 56 photomultipliers and calculates independent luminosities for each of the 3 colliding bunches in PEP. Design considerations, measurement techniques, and sources of error in the luminosity measurement are discussed.

Introduction

The measurement of the luminosity in a storage ring has traditionally been made by measuring the rate of small angle Bhabha ( $e^+e^- \rightarrow e^+e^-$ ) scattering. The luminosity monitor described in this note is installed in interaction region 12 of the Positron-Electron Project (PEP) and is part of the MKII Detector.

This luminosity monitor uses 24 defining counters and 4 calorimetric lead scintillator shower counters to define four axes of particle scattering. These scintillation counters excite 56 photomultipliers and an electronic system processes the phototube signals. The electronic system measures Bhabha rates and background rates for two counter-defined solid angles, and measures these rates for each of the three colliding bunches in PEP.

This rate information is used to calculate two types of luminosity for each of the three bunches, a fast (2 minute) Gross measurement with 15% error, and a slower precise measurement with potential 3% error. The Precise Luminosity is used in the analysis of the MKII detector data, and the Gross measurement is utilized by the PEP operators to rapidly tune machine parameters and log machine performance. The bunch specific measurements allow studies to be done on the particle distributions in the six bunches.

Principle of the Luminosity Measurement

For a specific particle interaction with scattering cross section  $\sigma_i$ , the luminosity  $\mathcal{L}$  and event rate  $R_i$  are simply related as

$$\mathcal{L} = \frac{R_i}{\sigma_i}$$

The scattering cross section  $\sigma_i$  is calculated using first order quantum electrodynamics, and for Bhabha scattering is a function of the defining counter geometry and the beam energy. The  $\sigma_i$  is calculated for small  $\theta$  as<sup>1</sup>

$$\sigma_i = \frac{4\alpha^2 (\hbar c)^2}{E_b^2} \int_{\theta_{\min}}^{\theta_{\max}} \frac{d\Omega}{\theta^4} \text{nb}$$

$\theta_{\min}$  and  $\theta_{\max}$  depend on the defining counter geometry. The shower counters subtend from  $\sim 21$  to 80 mr. For the system in the MKII detector,  $E_b \sigma_{\text{gross}}$  (including all 8 gross) is found to be 1,030,000 (GeV)<sup>2</sup> Nb, while the  $E_b \sigma_{\text{precise}}$  is 60840 (GeV)<sup>2</sup> Nb.

The event rate directly measured in the counters includes background events from beam-gas scattering, energy degraded particle scattering, and cosmic background. This background is measured and subtracted on-line in a bunch specific manner by electronically de-

laying one-half of the detector signals by one machine revolution time and measuring a coincidence rate of these delayed signals. The event rate R is calculated in this measurement as

$$R_i = \frac{N_{iR+B} - N_i B}{T_{\text{total}} - T_{\text{dead}}}$$

where  $N_{iR+B}$  = number of real and background events of Type i

$N_i B$  = number of background events of Type i

$T_{\text{total}}$  = total time of measurement

$T_{\text{dead}}$  = dead time of measurement.

The four event types in this measurement are defined as (please refer to Fig. 1):

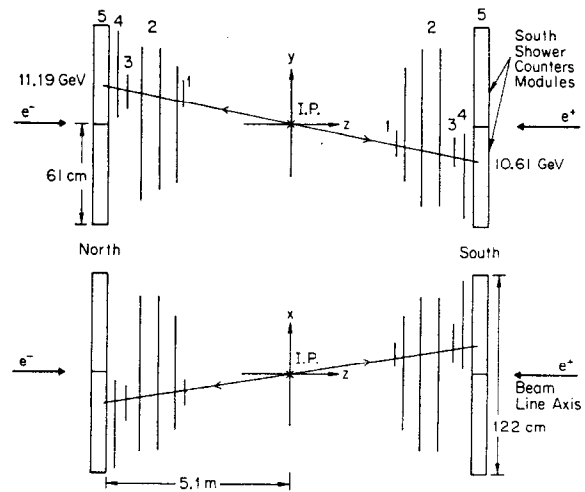

- 1 Acceptance Defining Counters
- 2 3 Planes of x-y Drift Chambers
- 3 Precise Defining Counters
- 4 Gross Defining Counters
- 5 Shower Counter Modules

Fig. 1. Example of a Symmetric Precise Bhabha at  $E_{\text{beam}} = 22$  GeV in two views (IP  $\equiv$  Interaction Point).

- Gross - collinear opposite shower counter + 1 gross counter on shower axis
- Symmetric Gross - collinear opposite shower counters + collinear opposite gross counters on shower axis
- Precise - Gross as above + an acceptance-precise coincidence on shower axis
- Symmetric Precise - symmetric gross as above + collinear opposite acceptance-precise coincidences on shower axis.

The luminosity system we describe measures these four event types on 5 axes (4 principle plus multiple axis events) for both real and background events for all three bunches, which is a total of 120 event categories.

Errors

Due to the symmetry of our geometry we are insensitive to movements of the beam position or pitch as these effects cancel to first order in  $\Delta\theta$ .<sup>1</sup> We still must take into account radiative corrections, scintillator efficiencies and systematic errors, the analyses of which give a design error in  $\mathcal{L}$  of 3%.<sup>2</sup>

\* Work supported by the Department of Energy, contract DE-AC03-76SF00515.

### Detector Hardware Description

There are 4 shower counter modules. Each shower counter consists of 18 layers ( $\sim 20$  radiation lengths) of lead-scintillator sandwich with waveshifter bar to lucite light guides. The first 5 layers are combined in four photomultiplier tubes to make up the Front Energy and the last 13 layers (14 radiation lengths) are combined to make the Back Energy. The resolution of this shower counter is  $15\%/\sqrt{E}$ .

The 24 defining scintillation counters are divided into 3 sets, gross, precise and acceptance, with four of each set arranged in quadrants on each end of the detector (see Fig. 1). These are precisely cut 1/2 and 1/4 inch thick scintillators. The gross counters cover a larger solid angle than the precise and acceptance, and are therefore used for the quick luminosity measurement. At a luminosity of  $10^{31} \text{ cm}^{-2} \text{ sec}^{-1}$  and  $E_{\text{beam}} = 15 \text{ GeV}$  the gross rate is 43 Hz. The precise and acceptance counters are placed further from the beam line, and put in coincidence to get a cleaner measurement of  $\mathcal{L}$  and have a rate of 2 Hz in the same conditions as above.

A set of 24 drift chambers (12 per side in 3 planes) with  $\sim 300 \mu\text{m}$  spatial resolution sit between the acceptance and precise counters and give x and y position measurement. These can be used to make corrections to the precise luminosity measurement, but also present  $\sim 9\%$  of a radiation length to the flight path of bhabbas we are measuring.

### Electronic Hardware Description

Figure 2 is a block diagram of the electronic system. The major elements of this system are 56 photomultipliers, associated high voltage supplies, fast analog circuitry for summing and discrimination, a digital processor for event categorization, a microprocessor module used as a 120 channel scaler, and associated CAMAC interfaces.

The analog circuit modules include linear summing circuits for the calorimeter signals, and commercial discriminators to provide NIM level signals for digital analysis. The shower counter discriminator thresholds are remotely programmed via CAMAC to provide a minimum energy threshold on line, typically set to  $E_{\text{beam}}/2$ .

Figure 3 is a block diagram of the digital proces-

sor. Two features of particular interest are the background subtraction technique and the coincidence logic. The background rate is measured using delayed coincidences generated from signals in four stage shift registers. These delayed signals are digitally generated internally and eliminate traditional delay cables.

The coincidence logic is unique in its density and organization. The coincidence circuits examine the 48 (32 real and 16 delayed) phototube signals and look for the counter coincidences described previously. Output signals identify real or background events, an axis code, and presence of the 4 coincidences. This circuitry is implemented using Schottky TTL Programmable Logic Arrays, and 5 ICs are used to provide 120 distinct coincidences.

The digital processor also includes status interfaces, dead time counters, live time counters, a bunch counter, and a CAMAC interface. A CAMAC programmable trigger system provides an arbitrarily prescaled trigger for any of the 4 event types. This trigger is used to record events in the MKII detector and the drift chambers for off-line data analysis and fine corrections to the measured luminosity.

The processor also contains a complete self-test capability. A PROM memory contains test patterns for 1024 beam crossings which, under CAMAC command, are processed by the measuring system. The event counts and calculated luminosity for these events are known constants and allow a check on the correct operation of all the digital circuitry.

The microprocessor module uses 2900 series bit slice parts to provide a very compact 120 channel scaler in 3 CAMAC slots. This microprocessor is passed 4 data words for each trigger from the digital processor. The microprocessor acts as an accumulator for the event data and is read by the computer system via CAMAC.

PEP's fundamental revolution frequency of 136 kHz produces an intra bunch period of 2.4  $\mu\text{s}$  in the  $3 \times 3$  colliding beam mode. The electronic system must detect and classify events within this period. Approximately 200 ns is required for the phototube and analog circuitry response, and the digital processor analysis time is 500  $\mu\text{s}$ . The microprocessor analysis time varies from 11 to 28 ns, depending on event complexity. An event buffer in the digital processor allows the storage of one event while the microprocessor is busy.

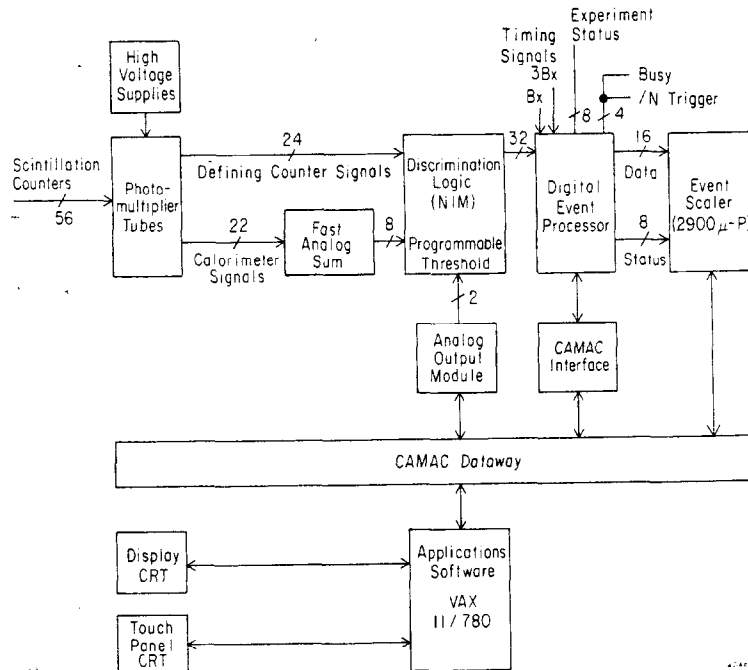

Fig. 2. Block diagram - signal processing.

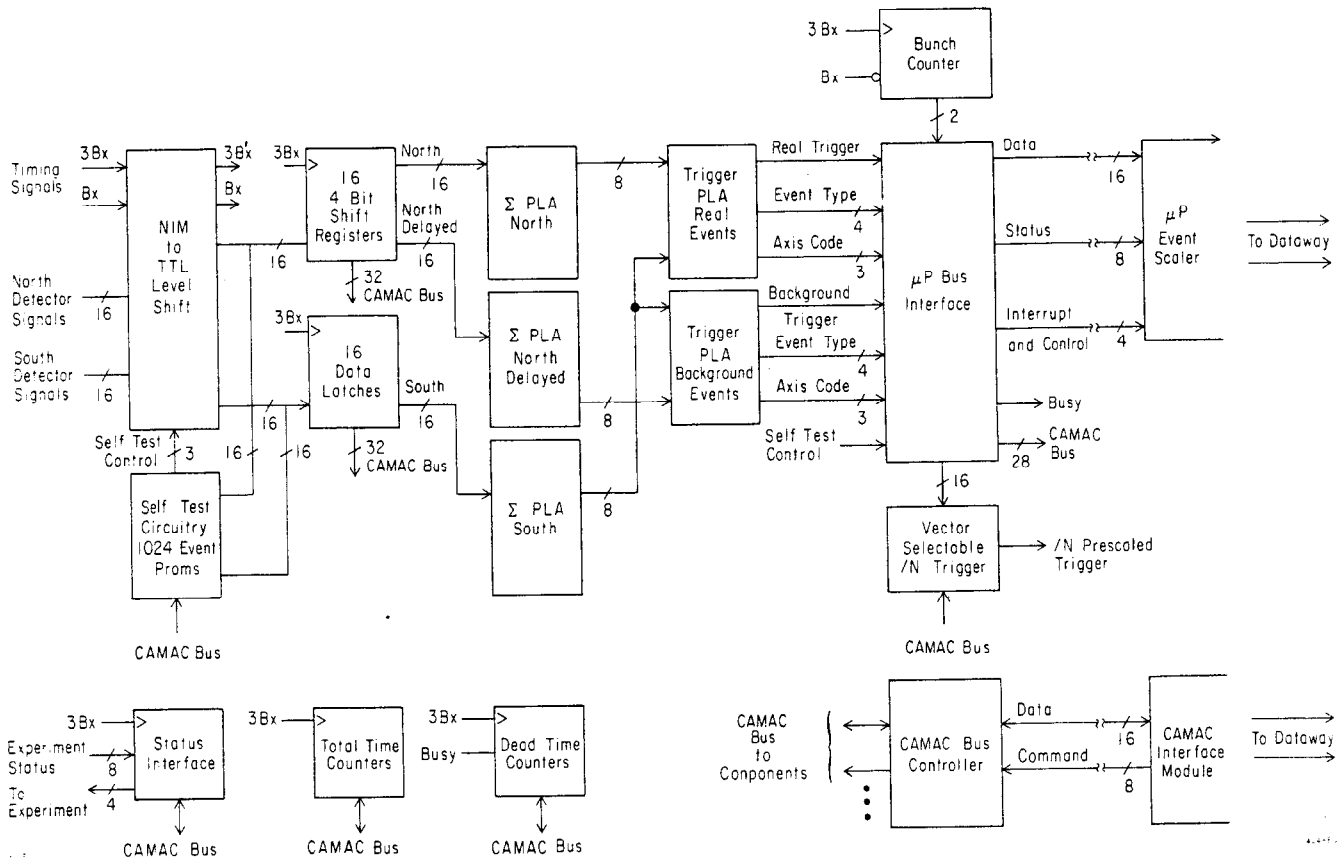

Fig. 3. Block diagram - digital processor.

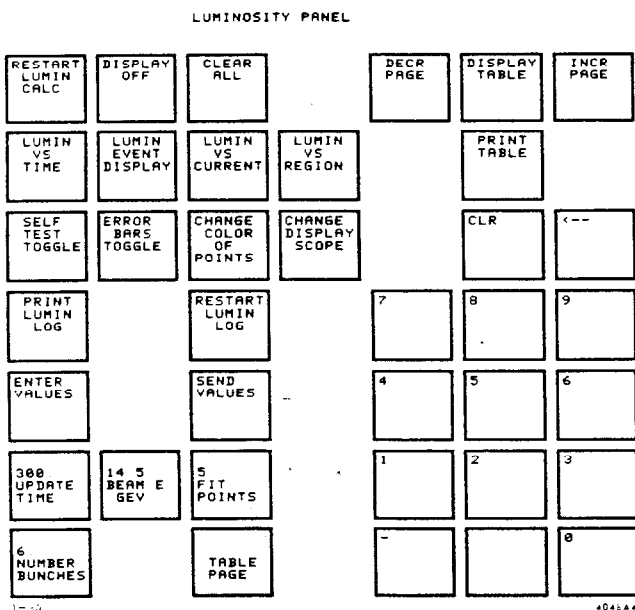

Fig. 4. Control touch panel.

Software Description

The luminosity monitor system used by the PEP operators is controlled from a touch panel in the PEP Control Room (Fig. 4). This panel allows the operators to specify certain operating parameters of the system and to select the type of output display desired. Figure 5 is a typical luminosity vs time curve for a PEP fill, showing the characteristic decay of the currents

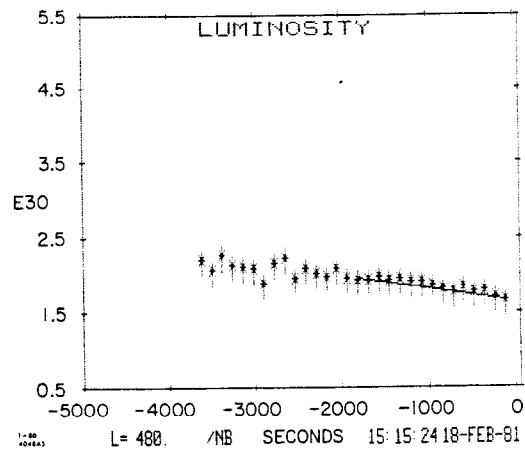

Fig. 5. Typical L vs T graph.

(hence luminosity) versus time.

The software to run this system is written in FORTRAN and runs on a VAX 11/780 computer system.

Acknowledgments

The authors would like to acknowledge the contributions of M. Breidenbach, D. Burke, J. Dorenbosch, M. Levi, R. Melen, P. Nemethy, D. Scharre and R. Vidal.

References

1. J. F. Crawford et al., "A precision luminosity monitor for use at electron-positron storage rings", Nucl. Instrum. Methods 127, 173-182 (1975).
2. D. L. Burke, M. E. B. Franklin, Stanford Linear Accelerator internal memo, September 12, 1980.