

DESIGN AND PERFORMANCE OF THE NEW CATHODE

READOUT PROPORTIONAL CHAMBERS IN LASS*

G. Aiken, D. Aston, W. Dunwoodie, W. B. Johnson, A. Kilert,
D. W. G. S. Leith, D. McShurley, B. Ratcliff, R. Richter[†],
S. Suzuki, S. Shapiro, J. Va'Vra, S. H. Williams

*Stanford Linear Accelerator Center, Stanford University,
Stanford, California 94305*

L. Bird^{††}, R. K. Carnegie, R. McKillan

Carleton University, Ottawa, Ontario, Canada K1S 5B6

T. Matsui, C. O. Pak

Nagoya University, Nagoya, Japan

ABSTRACT

The design and construction of a new proportional chamber system for the LASS spectrometer are discussed. This system consists of planar and cylindrical chambers employing anode wire and cathode strip readout techniques. The good timing characteristics of anode readout combine with the excellent spatial resolution of cathode readout to provide powerful and compact detectors. Preliminary resolution data are presented along with operating characteristics of the various devices.

Paper presented at
The 1980 IEEE Nuclear Science Symposium
November 6, 1980

* Work supported by the Department of Energy under contract No. DE-AC03-76SF00515.

† Present Address: CERN, 1211 Geneva 23, Switzerland.

†† Present Address: Simon Fraser University, Burnaby, Canada.

I. INTRODUCTION

A second generation of proportional chambers has been designed, constructed and installed in the LASS spectrometer at SLAC. These new chambers replace the cylindrical and planar capacitive diode readout spark chambers previously employed in the solenoid detection system. Although these new cylindrical and planar chambers differ markedly in both geometry and construction, they do share many common features. Both employ anode wire and cathode strip readout within the same gap, the anode wires all have approximately 2 mm spacing and the half-gaps are approximately 5 mm. The anode wire readout is the same as that used in LASS for the past few years,¹ but the cathode strip readout is new and is described in a paper submitted to the 1980 Nuclear Science Symposium.²

These chambers have a readout resolving time of 150 nsec or less, which is essential for taking data in the high instantaneous data rate environment that obtains at SLAC. They have high efficiency for multiple hits, and permit the formation of match points (three dimensional space points used in track finding) in a simple unambiguous way.

This paper describes the physical characteristics of these chambers and presents their operating parameters. The algorithm employed to convert strip pulse height information to a coordinate value is discussed and preliminary results on resolution are presented.

II. THE PLANAR CHAMBERS

Each planar chamber has one plane of anode wires and two cathodes. The anode plane is composed of 768 vertical wires of 0.0008" diameter gold plated tungsten spaced 0.080" apart; a subset of five guard wires shapes the field at each end. Four equally spaced horizontal support wires leave a maximum unsupported length of 12.4", and sixteen polyurethane foam spacers, .25" x .25" x .20", epoxied to these support wires serve to maintain the half-gap width of 0.200".

Each cathode is formed of aluminum-mylar laminate etched to provide a pattern of 192 strips running at $\pm 45^\circ$ to the anode wires. The strips are nominally .270" wide and the strip separation is 0.050". Each of the cathodes has been surveyed after mounting on its support frame so that deformations caused by stretching can be taken into account in the coordinate reconstruction. Electrical connections are made to printed circuit cards in the frame by bending #22 AWG wire over the strips and cementing it to the aluminum with conducting epoxy. Fig. 1 is an assembly drawing of a planar chamber.

The chamber is operated with positive high voltage on the anode sense plane, while the cathode planes are at ground potential and the support wires are at approximately half the anode potential. An isolation capacitor (470 pf, at 6 kV) is used on each anode wire to protect the readout circuitry.

Each chamber has an active area approximately 61" square, and has a central region deadened by the inclusion of a mylar

plug (6.5" in diameter) epoxied to each cathode so that the high intensity beam region does not fill the central strips with data, thereby causing ambiguities and overlaps. This central region is covered by three planes of conventional 1 mm wire spacing anode readout proportional chamber, both chambers being mounted on opposite sides of a common support frame.

III. THE PROPORTIONAL CYLINDERS

Six proportional cylinders have been designed and built to surround the LASS liquid hydrogen target. The design emphasis has been to create a low mass detector for both transverse and forward-going particles, which provides large solid angle coverage, and yields dual coordinate readout from each gap. These chambers have anode wires of 0.0008" gold plated tungsten parallel to the beam axis; small angle stereo is provided by helical cathode strips at $\pm 10^\circ$ to the axis for cylinders 1-4 and $\pm 15^\circ$ for cylinders 5 and 6. A compilation of the relevant physical parameters of the cylinder and planar packages is presented in Table I.

The cylinder construction consists of a double cylinder of aluminum mylar laminate and paper honeycomb (Hexcel) resulting in a thickness of approximately 0.11 g/cm^2 . For each cylindrical detector, the inner cylinder supports the inner cathode and the anode wires, while the outer cylinder supports the outer cathode. The anode to cathode spacing is determined by Rohacell foam rings at the downstream end and G-10 rings at the upstream end. The gas seal is provided by a layer of RTV exterior to these rings. The cathodes are etched on the aluminum mylar laminate and have strip

widths as listed in Table I. The anode wire spacing is approximately 2 mm, and the cylinder active length is 100 cm for cylinders 1-4 and 87 cm for cylinders 5 and 6. The anode wires are supported at mid-length by a lucite support ring which has an insulated charge leakage wire attached and to which the anode wires are glued with Humaseal. Fig. 2 is a photograph of the cylinder package mounted to the inner surface of the upstream flux return disc of the LASS Solenoid.

IV. OPERATING CHARACTERISTICS

All of these new chambers use a magic gas mixture of 21% Isobutane, 4% Methylal, 0.25% Freon 13 B1 and the balance Argon. Fig. 3 shows a representative plateau curve of efficiency versus high voltage for a planar chamber in use at LASS. Since each chamber must be operated at that voltage for which the cathode readout is efficient, the anode cluster size must be limited by adjusting the threshold of the anode readout. The plateau curve presented for the anode readout is one for which the threshold for pulse detection was set at 720 μ V (-12 V on the reference voltage) rather than at 300 μ V which has been the nominal operating point for the conventional proportional chambers in the LASS system. The spatial resolution (σ) of the anode coordinate measurement for chambers having 2 mm wire spacing has been measured to be approximately 0.6 mm. Fig. 4 shows a typical variation of pulse height with high voltage for the central cathode strip of a cluster.

V. DISCUSSION OF PULSE HEIGHT DATA

The objective in building chambers of the type discussed above is to be able to use a series of pulse heights on adjacent broad

cathode strips for the precise determination of a coordinate somewhere on one of the strips. For such a series of adjacent strips, that strip which has the highest pulse height may be readily determined. The assumption is then made that the true coordinate lies somewhere within this central strip. For the strips on either side of the central strip, the ratio of the pulse height to that of the central strip may be calculated and a scatter plot of one ratio against the other generated. Independently of any assumption concerning the relationship of pulse height to position there must exist a unique locus of points on this plot if we are to succeed in generating an algorithm relating pulse height information to position. In Fig. 5 such a scatter plot is shown for data from one of the planar PWC's.

Many authors have attempted to describe the positive charge distribution on a PWC cathode caused by an avalanche at the anode³⁻⁸. These studies have been made primarily with test arrangements placed in well defined hadron beams or have used X-ray sources. The spatial resolution (σ) obtained varies from 86 - 150 μm in the case of particle beams to approximately 35 μm for the X-ray source. The results achieved seem to be independent of readout electronics, but vary significantly with gas composition, gas gain, time gate, and chamber parameters like gap size, wire spacing, and strip dimension. In reference 7, the optimum geometry for the best spatial resolution is discussed and the recommendation made that the cathode strip width and the half-gap be approximately equal. In most of these analyses a centroid method has been used for

extracting the coordinate value from the pulse height information.

In contrast, the data presented in this paper are obtained from large chambers in a working spectrometer environment. A balance had to be struck between striving for the ultimate in spatial resolution and constructing a large system at a minimal cost. To this end, cathode strip widths larger than the half-gap are used. Furthermore, the studies to be discussed below indicate that the centroid method is not the most effective algorithm for this system.

Consider a point charge between two equipotential infinite conducting planes. The charge density induced at any point on the conducting planes is obtained from an infinite series of pairs of image charges. The solution to this idealized problem results in the locus, (a), shown in Fig. 6 for the geometry of the planar chamber (strip width 0.320", half-gap 0.200"). This curve qualitatively describes the data presented in Fig. 5, but proves to be very sensitive to half-gap and strip width values. For example, the dashed curve, (b), of Fig. 6 represents the locus for the strip width being equal to the half-gap of 0.200". Empirically, it is found that the intense band of Fig. 5 is well-represented by the shaded region, (c), of Fig. 6; the upper and lower boundaries of this region correspond to solutions of the idealized problem for a strip width of 0.320" and half-gap values of 0.190" and 0.150" respectively.

The solution to the idealized problem yields a relationship between pulse height ratio and position within the central strip as

shown in Fig. 7; this is clearly non-linear. The shaded region, (c), of Fig. 6 corresponds to the shaded area of Fig. 7, implying that spatial resolution varies with position across the strip. Furthermore, the lower of the two ratios contains little or no information except near the center of the strip. However, in this region the position measurement for the two ratios may be combined in such a way as to improve the resolution.

Using such an algorithm, information from the two cathodes may be combined to yield a coordinate which may be compared to the actual anode coordinate. The distributions of this difference excluding and including the mechanical corrections resulting from the foil survey are plotted in Figs. 8(a) and 8(b) respectively. The resolution is seen to be significantly improved as a result of the mechanical corrections, the estimated half width at half maximum being ~ 0.35 mm in Fig. 8(b) compared to ~ 0.65 mm in Fig. 8(a). For purposes of illustration, Fig. 9(a) shows a map of the anode plane generated by the paired cathode coordinates in the vicinity of the deadened region. A similar map on a finer scale is shown in Fig. 9(b) for the case in which the chamber was displaced horizontally by 8"; the beam spot is well defined and individual wires are clearly discerned.

It should be emphasized that in generating the calculated x coordinate of Fig. 8, it has been assumed that the e and p coordinates correspond to orthogonal projections of the x, y location of the avalanche at the anode plane, independently of the angle of the incoming track. The good resolution obtained supports

the validity of this assumption. In a multitrack high magnetic field environment such as the LASS spectrometer where a typical event may have six or more charged tracks, the ideal coordinate measuring device is one in which all coordinates are measured at the same position along the beam (z). For the existing single readout chambers, the z separation of the coordinate planes typically results in the creation of two to three times as many space points as are real. With the new, dual readout chambers, the fact that the three coordinates are in effect measured at the same z greatly reduces this problem. This has a direct impact on the accuracy and speed of the track finding programs.

Fig. 10 shows typical pulse height distributions for a planar chamber operated at 3500V. Fig. 10(a), (b) is the distribution of pulse height for the central strip and Fig. 10(c) that for the larger of the pulse heights on the adjacent strips. It should be noted that in Fig. 10(a) only about 1% of the data fall in the overflow bin. Avalanches which are so large as to saturate the pulse height for the central strip can still be used to generate coordinate values. An algorithm can be generated which uses only the left and right-hand strips to predict the coordinate values, since the technique discussed above requires only two strips rather than the three or more needed for the centroid method.

In Fig. 10(b) the most probable peak pulse height occurs approximately at channel 450. This corresponds to a charge of about 15 pC at the SHAM input and is equivalent to a charge of approximately 400×10^{-15} coulomb collected by the electronics² on that cathode strip.

Fig. 11 shows the sum of the pulse heights on one cathode compared with that on the other cathode when anode corroboration is required. It is expected that the width of the diagonal band will be significantly reduced when channel to channel pulse height calibration corrections are incorporated. The linearity of the plot implies that the number of trial combinations of coordinates in situations where more than one particle passes through the chamber may be reduced by comparing pulse height sums and pairing cathode coordinates of similar total charge. This additional information should then further reduce the number of spurious space points generated. It is amusing to note here, that this is one of the few instances where Landau fluctuations are of some benefit. This feature is demonstrated in Fig. 12. Two particles having passed through the chamber yield two cathode coordinates each. Anode corroboration selects the correct pairings and it can be seen that the correct pairings are those which have similar total charge.

It should be emphasized that the data presented in this paper are preliminary in nature. Channel to channel pulse height corrections have not yet been incorporated, and, in particular, pedestal subtractions have not yet been done on an individual channel basis. The necessity for applying quadratic corrections to the gain has also not yet been investigated. In addition, studies are still under way to select the optimum operating voltage for the individual chambers.

Preliminary results for the cylindrical chambers are similar to those presented above.

VI. SUMMARY AND CONCLUSIONS

A second generation of proportional chambers has been developed for use in the LASS spectrometer at SLAC. These chambers employ both anode and cathode strip readout within the same gap, and yield a resolving time for both the anode and cathode readout which is less than 150 nsec. The spatial resolution is good ($\sigma \leq 300$ mm), and is obtained by utilizing a new algorithm for conversion of pulse height data to coordinate value. Three dimensional space points are determined from coordinate information generated by a single gap, thus greatly simplifying the problem of pattern recognition for charged particle tracks in an intense magnetic field. It has also been shown that the problem of handling multiple hits may be greatly simplified by pairing coordinates having approximately equal total charge on each cathode foil.

The observed spatial resolution has verified the stability of the readout electronics which has been crucial to the above studies. In addition, it has been shown that good spatial resolution can be obtained with strip widths substantially larger than the half-gap, thereby resulting in a significant saving in readout electronics costs.

VII. ACKNOWLEDGEMENTS

The authors would like to thank Bill Walsh, Frank Holst and Annette Nicholson for their help in assembling the system. We would also like to thank Herman Zaiss and his entire organization at SLAC for their help in constructing the planar proportional

chambers; in particular, special thanks are due Hardy Bowden and Bill Freet who labored many long months on them. At Carleton University special thanks are extended to Louis Raffler, Barbara Ellspermann and Larry Sainsbury for their fine efforts in building and testing the cylindrical package.

REFERENCES

1. A Proportional Chamber Front End Amplifier and Pulse Shaping Circuit, S. L. Shapiro, M. G. D. Gilchriese and D. G. McShurley SLAC-PUB-1713, February 1976; IEEE Trans. Nucl. Sci. NS23 (1976) No. 1 264-268.

A Deadtimeless Shift Register Style Readout Scheme for Multiwire Proportional Chambers. S. L. Shapiro, M. G. D. Gilchriese, R. G. Friday, SLAC-PUB-1714, February 1976; IEEE Trans. Nucl. Sci. NS23 No.1 269-273.
2. A Low Noise PWC Cathode Readout System. E. Cisneros, D. Hutchinson D. McShurley, R. Richter, S. Shapiro. Presented to the 1980 IEEE Nucl. Sci. Symposium; SLAC-PUB-2641, Oct. 1980.
3. G. Fischer and J. Plch NIM 100 (1972) 515-523.
4. G. Charpak, F. Sauli; NIM 113 (1973) 381-385.
5. A. Breskin, G. Charpak, C. Demierre, S. Majewski, A. Policarpo, F. Sauli, and J. C. Santiard; NIM 143 (1977) 29-39.
6. G. Charpak, G. Peterson, A. Policarpo and F. Sauli; NIM 148 (1978) 471-482.
7. E. Gatti, A. Longoni, H. Okuno, P. Semenza; NIM 163 (1979) 83-92.
8. A Position Sensitive Parallel Plate Avalanche Counter to Detect Minimum Ionizing Particles. M. Urban, W. R. Graves, C. Heil. Presented at the International Conference on Experimentation at LEP, Uppsala, Sweden June 16-20, 1980. Submitted to NIM.

FIGURE CAPTIONS

1. Assembly drawing of a planar proportional chamber.
2. Photograph of the cylinder package mounted to the inner surface of the upstream flux return disc of the LASS Solenoid.
3. A representative plateau curve for a planar PWC.
4. A representative curve showing pulse height variation versus high voltage for a planar PWC.
5. Scatter plot showing the left/center pulse height ratio plotted against the right/center ratio.
6. The locus of points for the solution to the idealized problem for:
 - a) planar chamber geometry: anode-cathode gap of .200"; conducting strip of 0.270"; insulating gap of 0.050";
 - b) anode-cathode gap of .200"; conducting strip of 0.150"; insulating strip of 0.050";
 - c) planar chamber geometry with anode-cathode gap set equal to 0.150" and 0.190" for the lower and upper curves respectively.
7. Plot of pulse height ratio versus position within the central strip.
8.
 - a) The difference between the coordinate generated from the two cathodes and the actual anode position prior to correcting the cathode data for mechanical distortion of the cathode foils.
 - b) The same plot after correcting for mechanical distortions.
9.
 - a) A map of the anode plane made by using cathode coordinates in the vicinity of the deadened central region.
 - b) The same plot on a finer scale after displacing the chamber horizontally by 8" to allow the incident beam to strike the active regions.

10. a) The distribution of pulse height for the central strip of a cluster from a planar chamber. (50 counts/bin)
- b) The distribution of Fig. 10(a) on a finer scale. (10 counts/bin)
- c) The distribution of the larger of the adjacent strip pulse heights. (10 counts/bin)
11. Scatter plot showing the relationship between the summed pulse height on one cathode and that on the other cathode when anode corroboration is required.
12. An illustration of the feature that the correct pairing of the cathode coordinates, as confirmed by anode corroboration, correlates clusters of similar total charge.

TABLE I

Cylinder Number	Anode Radius (cm)	Number of Anode Wires	Cathode Pitch* (mm)	Anode/Cathode Gap (mm)	Number of Strips on Inner Cathode	Number of Strips on Outer Cathode	Stereo Angle
1	6.048	190	5.00	4.775	70	82	10°
2	9.549	300	5.00	4.775	114	126	10°
3	12.987	408	8.00	5.093	98	106	10°
4	16.552	520	8.00	5.093	126	134	10°
5	29.41	924**	10.00	5.767	175	182	15°
6	49.02	1540**	10.00	5.767	294	301	15°
Planar Chamber	—	768	8.00	5.080	192	192	45°

* Pitch is defined on a circle perpendicular to the axis.

** For the anode readout, four wires are read out together as one coordinate. Adjacent wires are connected together at the chamber, then near the amplifiers adjacent wires are again grouped together on a pc board.

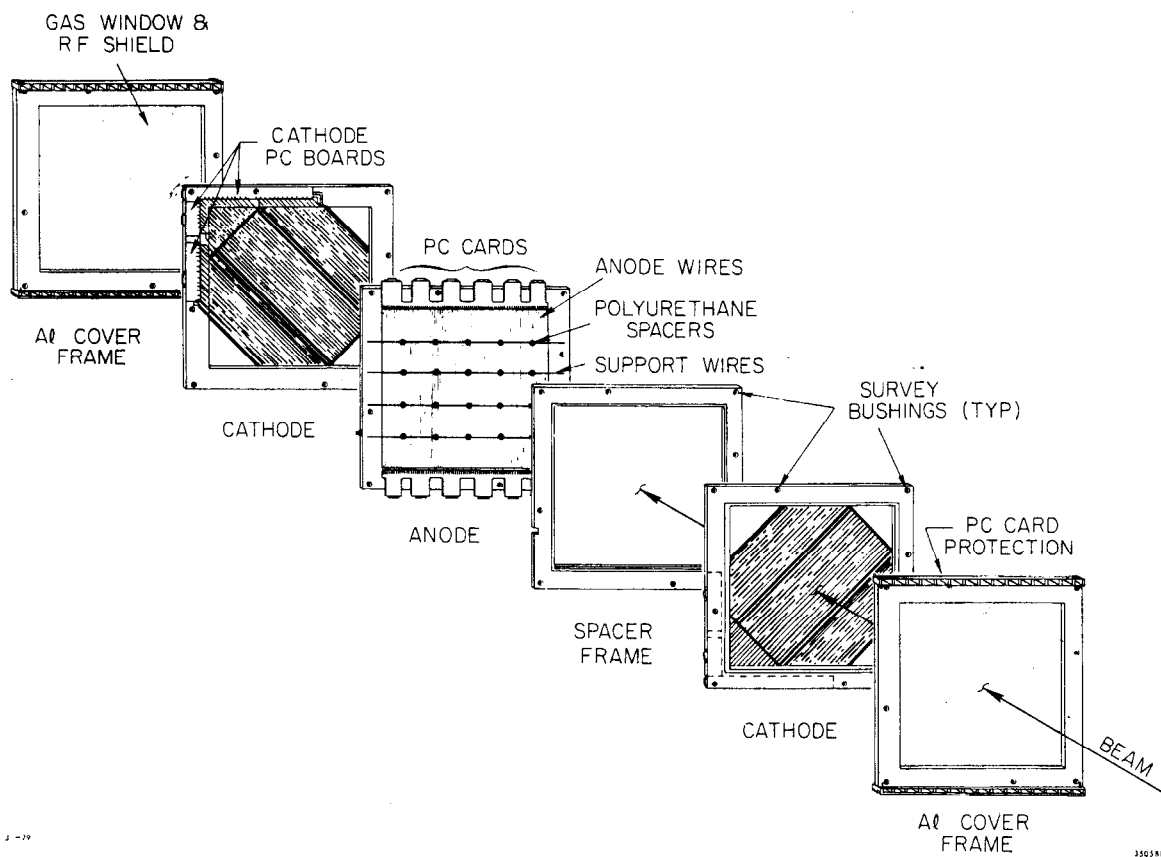

Fig. 1

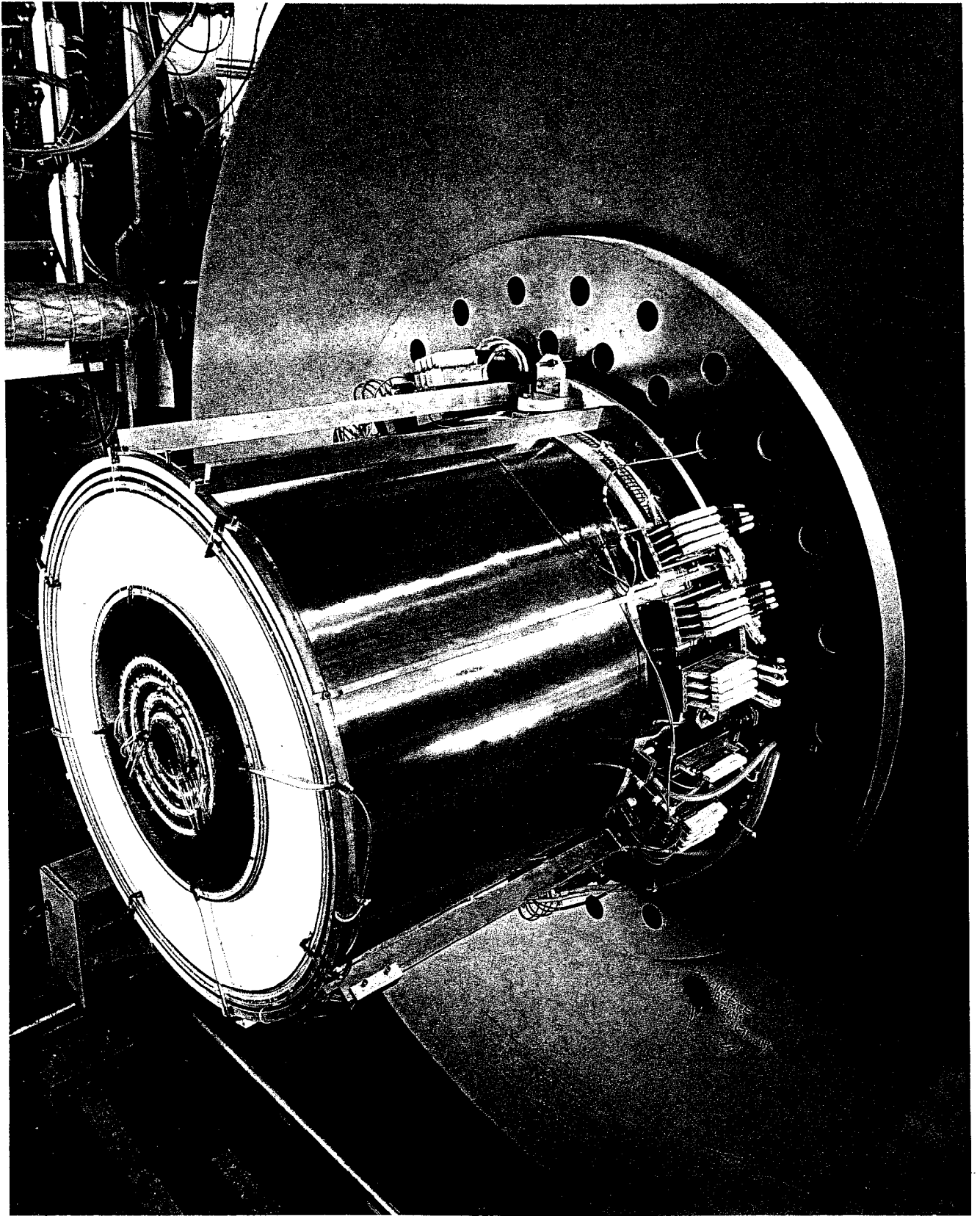

Fig. 2

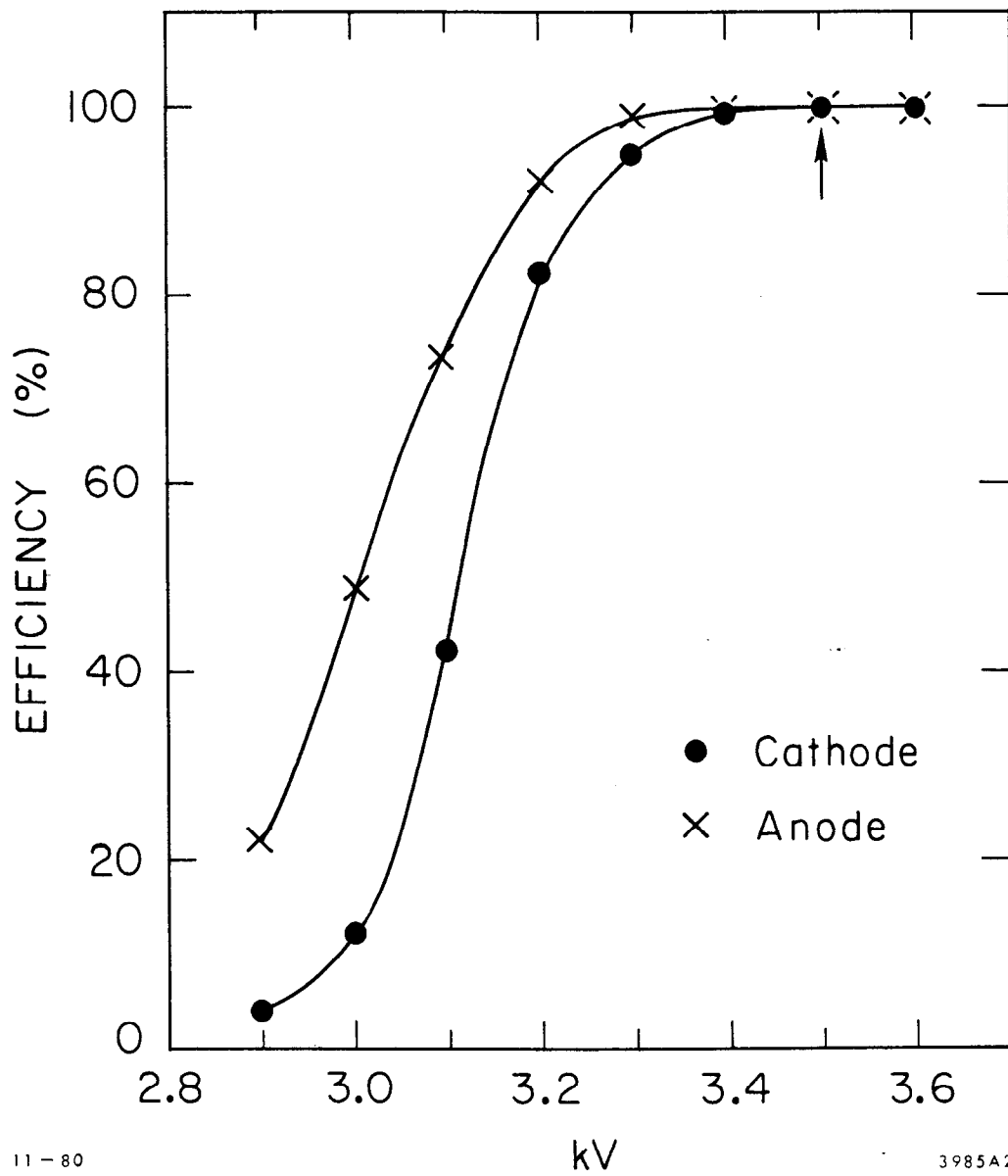

Fig. 3

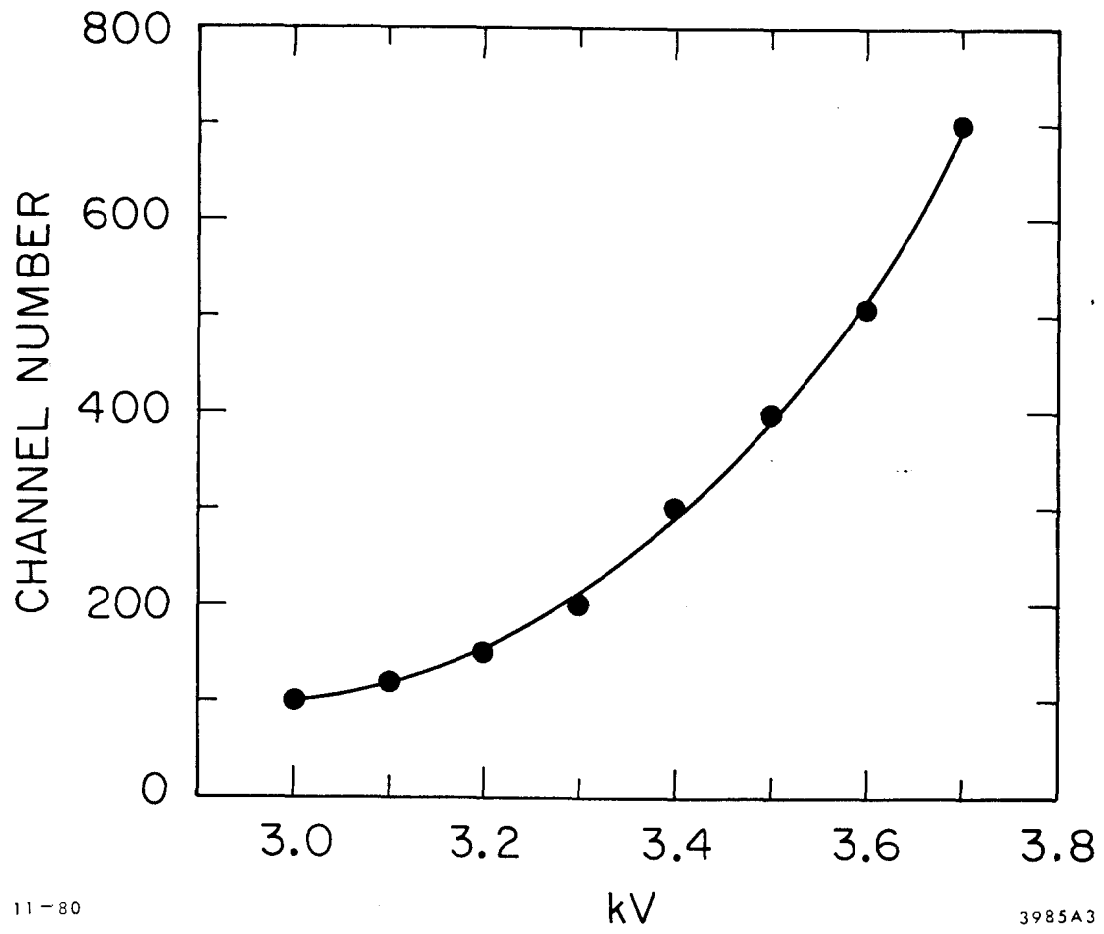
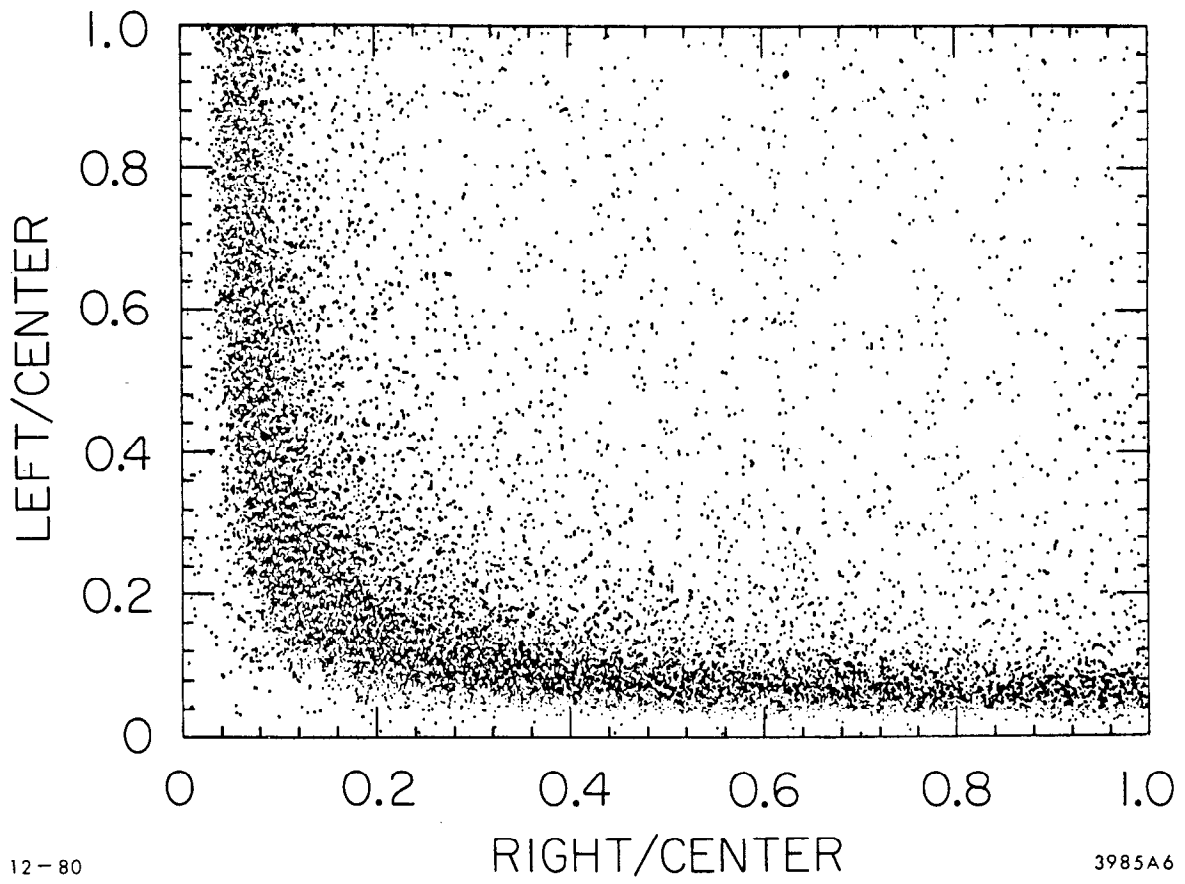

Fig. 4



12-80

3985A6

Fig. 5

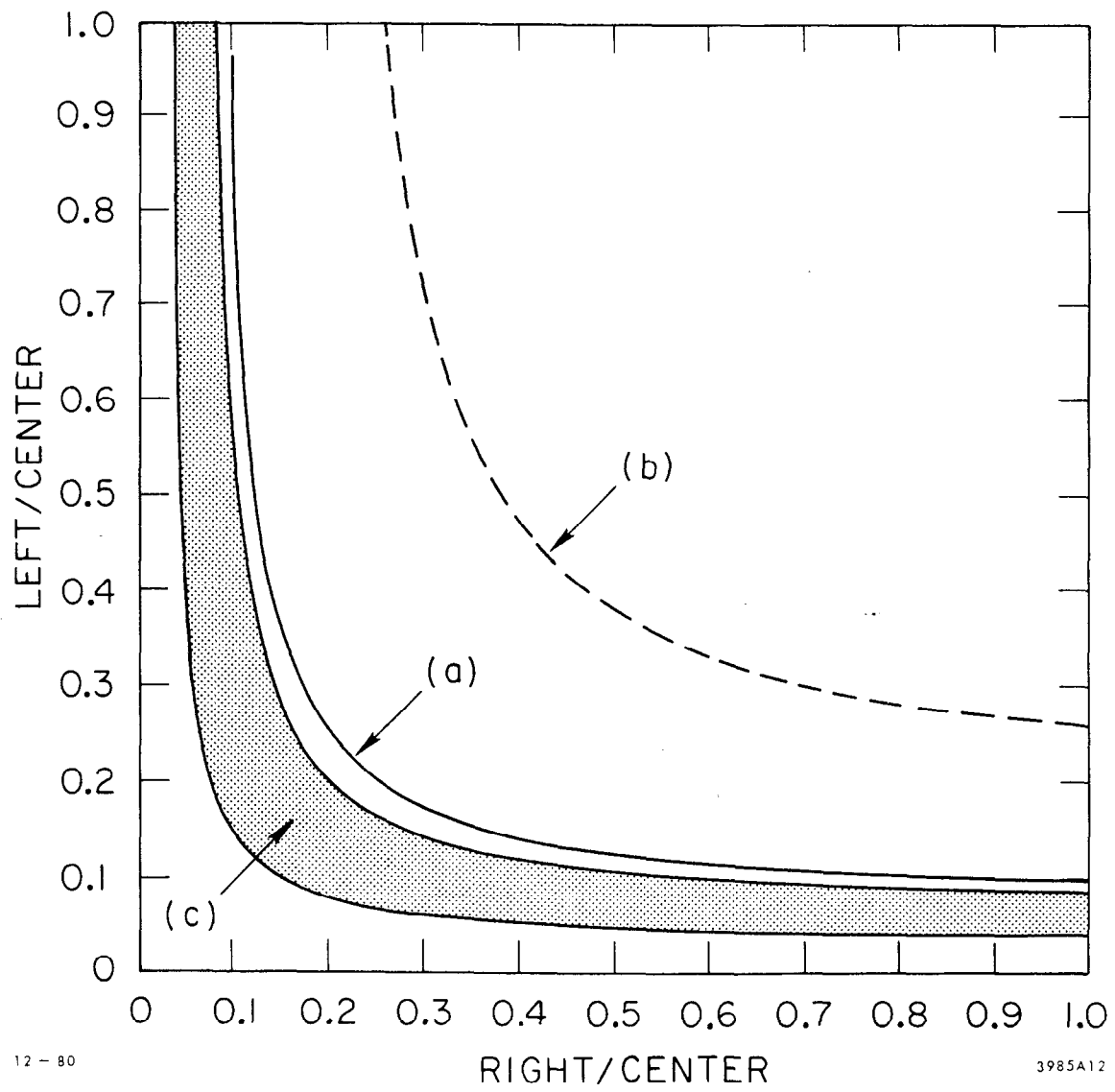

Fig. 6

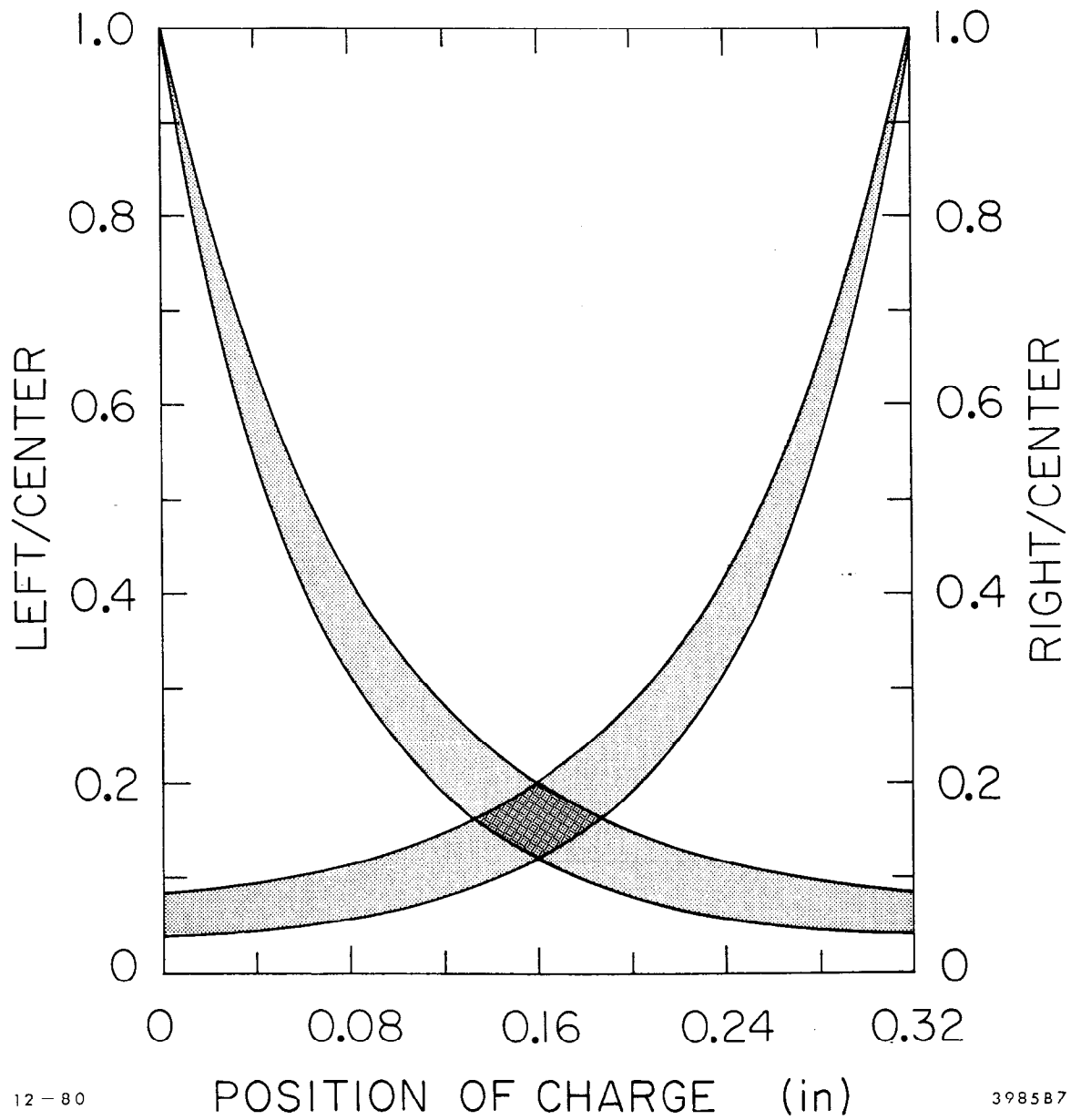
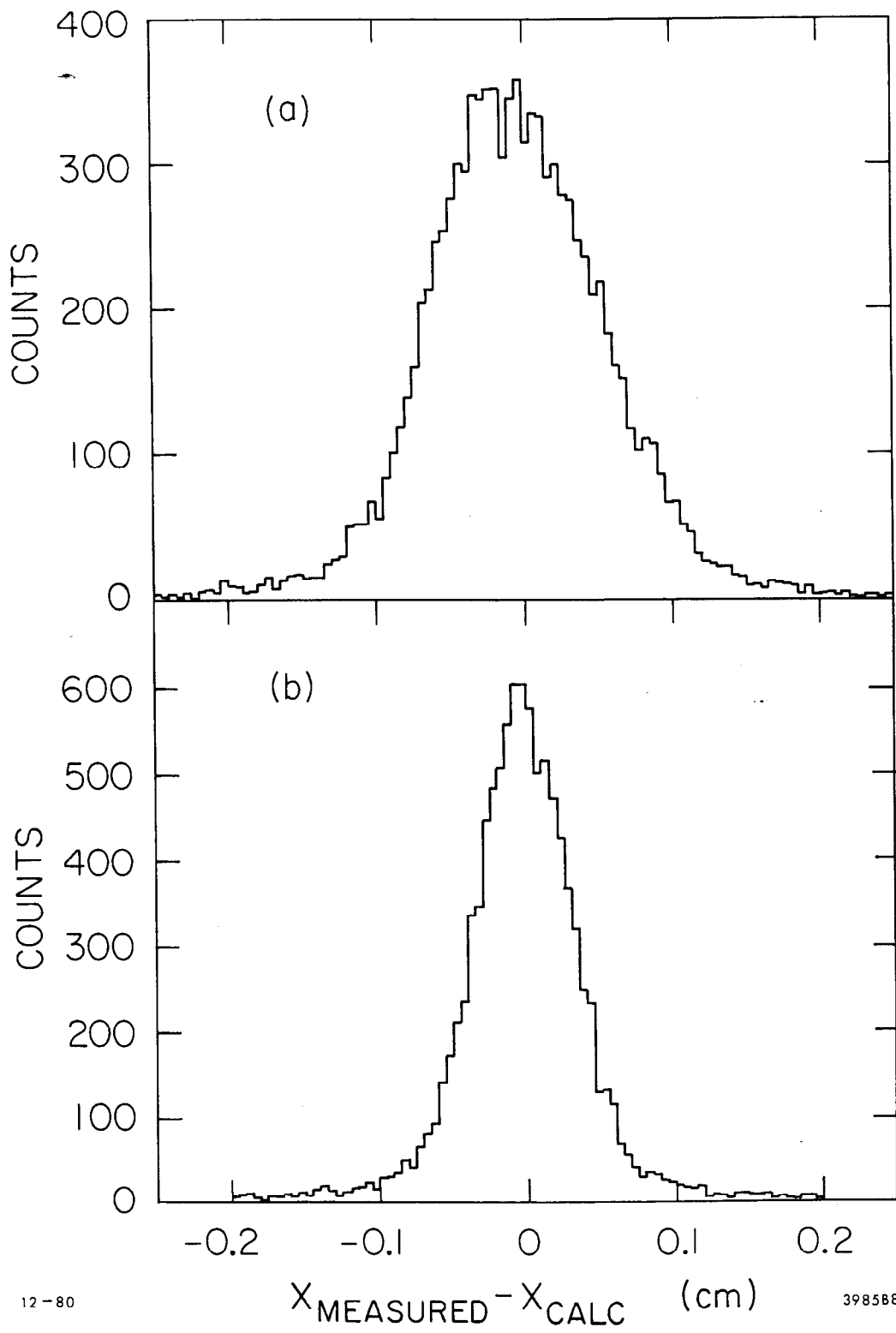

Fig. 7



12-80

398588

Fig. 8

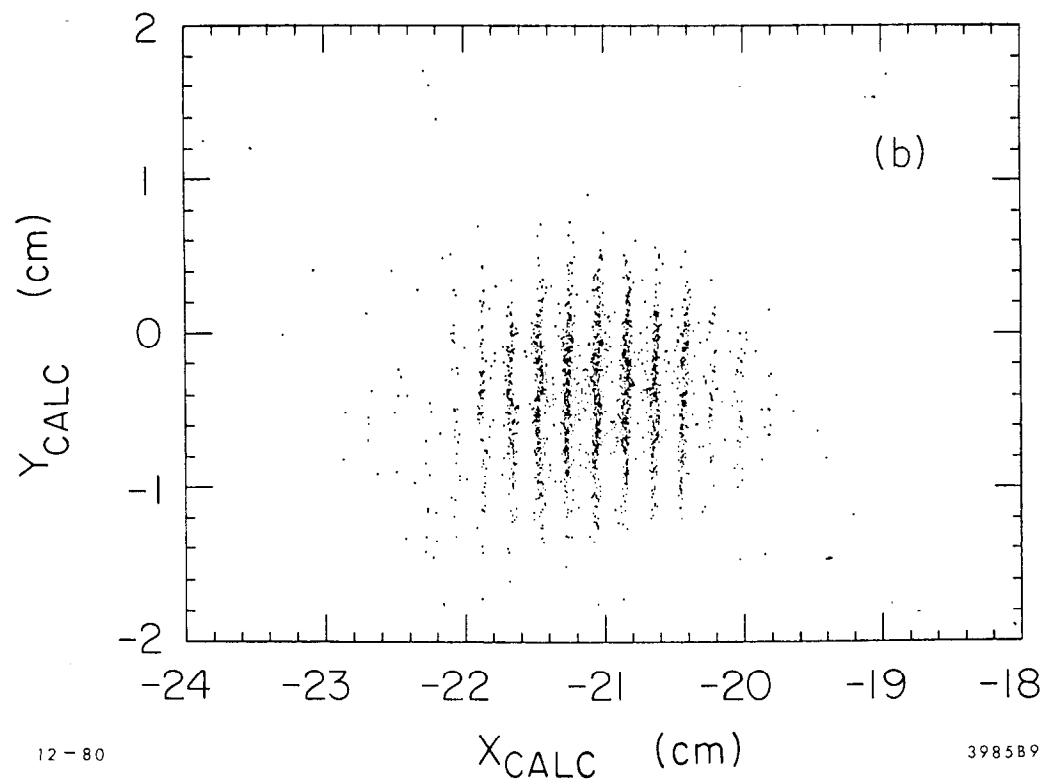
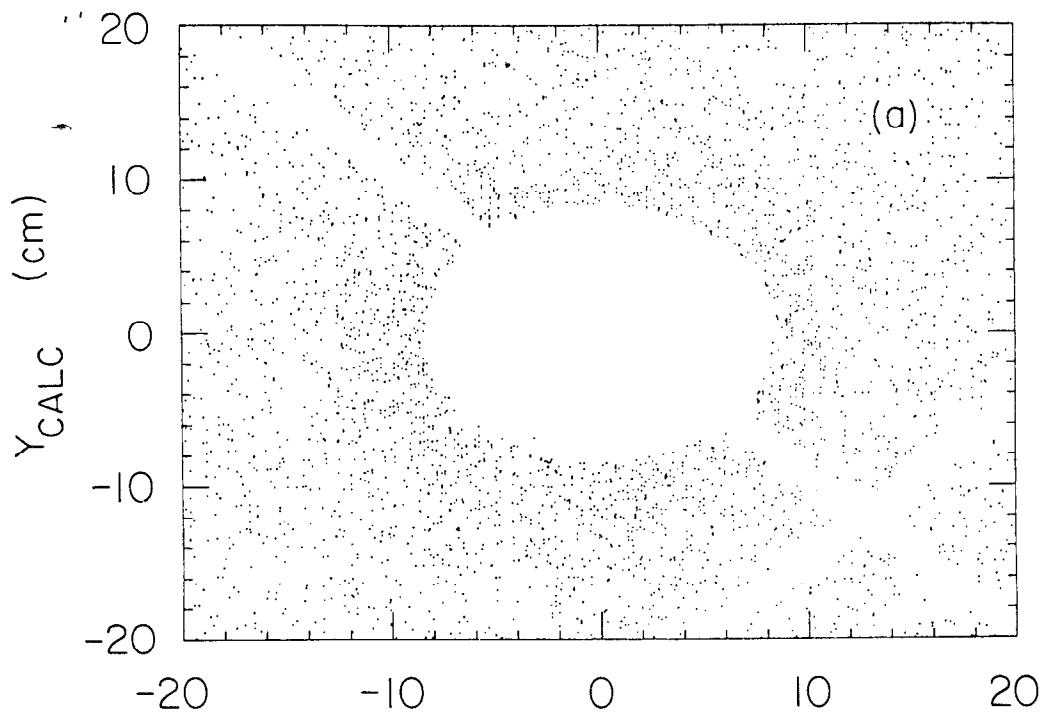

Fig. 9

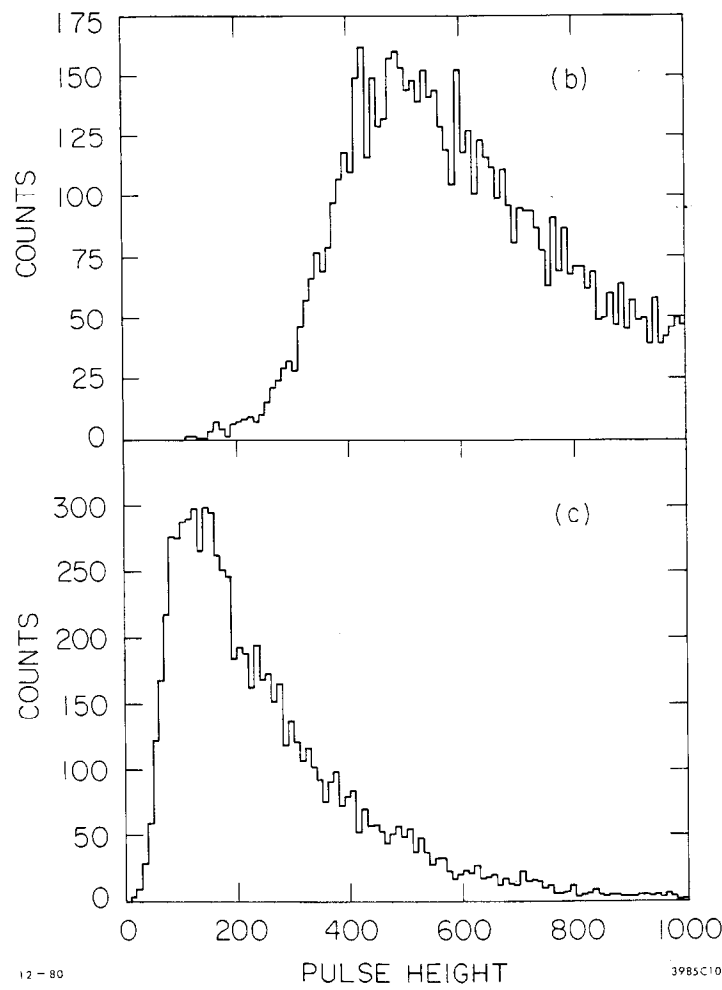
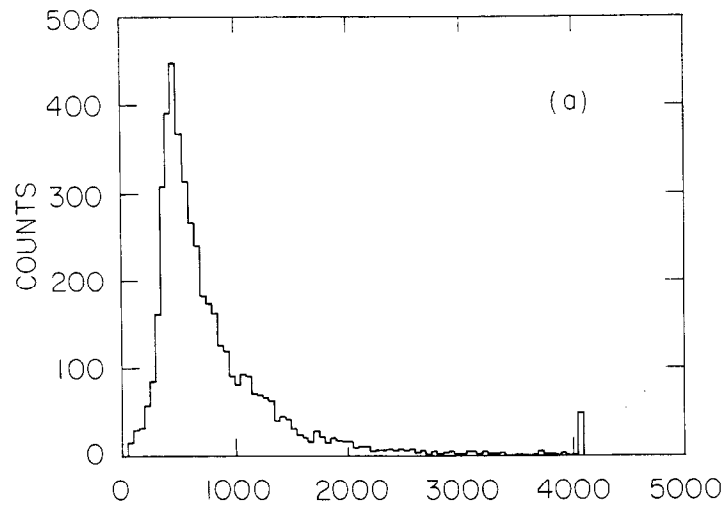
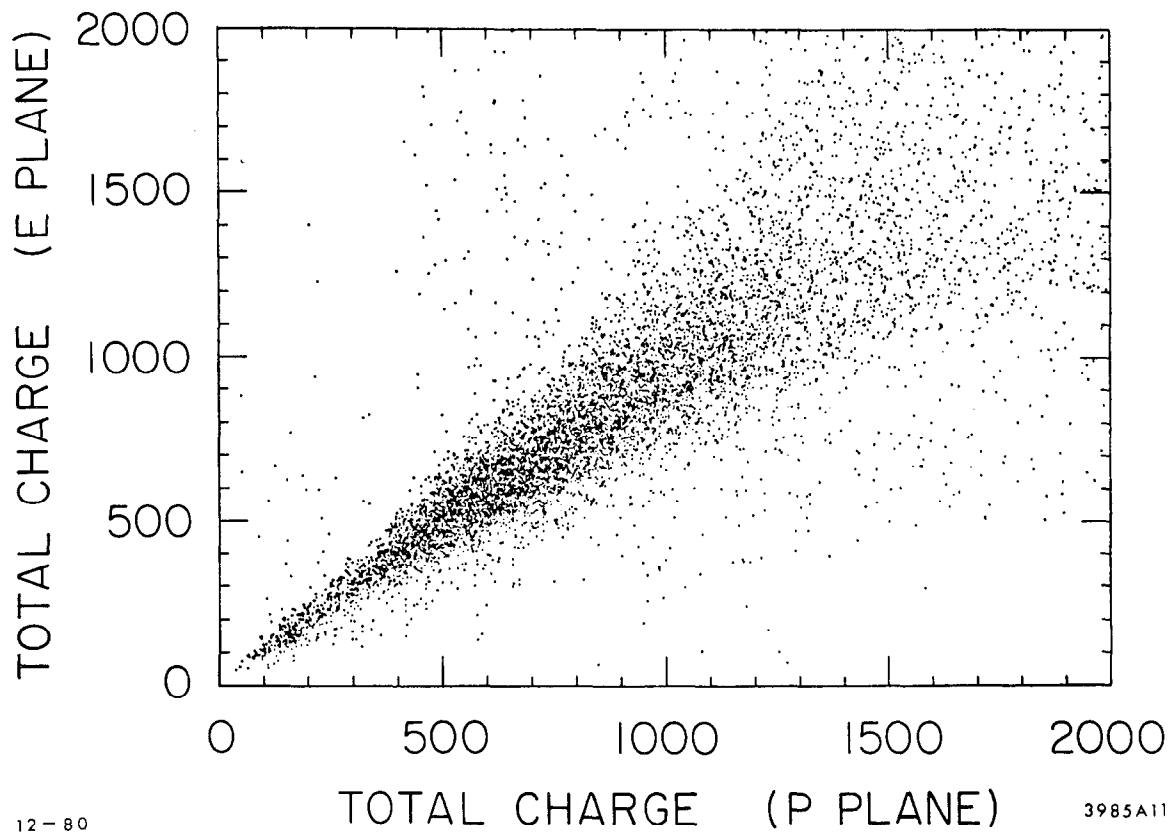

Fig. 10



12-80

3985A11

Fig. 11

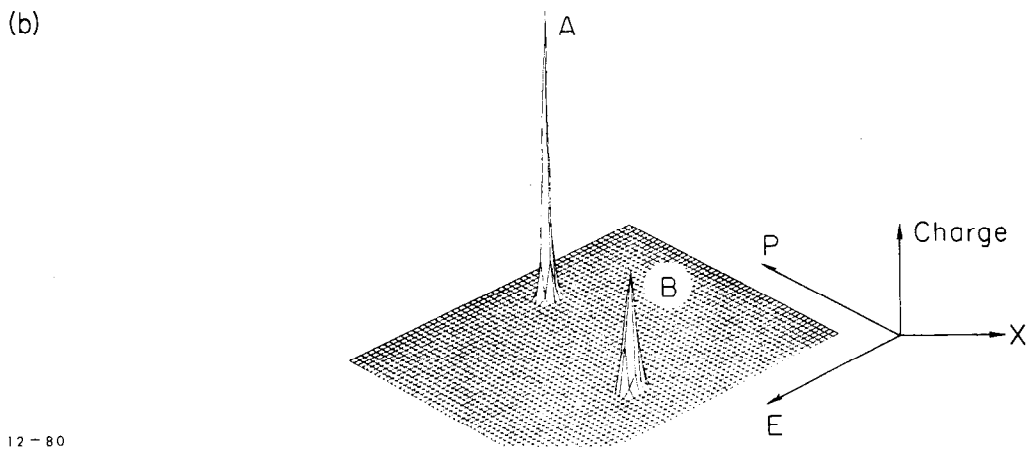
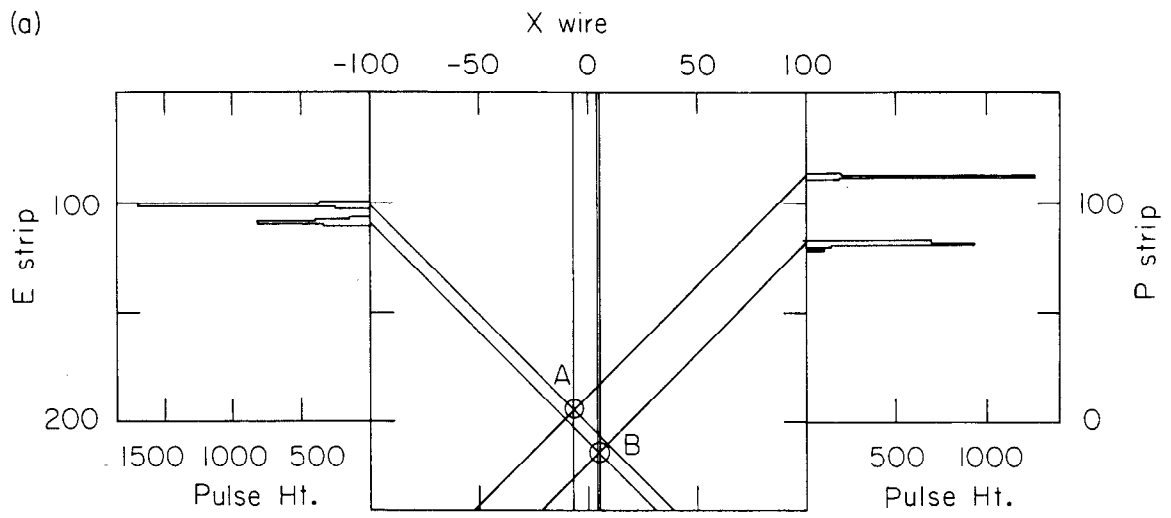

12-80

3985C4

Fig. 12