

MEASUREMENT OF THE BRANCHING FRACTION
FOR THE CABIBBO SUPPRESSED DECAY $\tau^- \rightarrow K^{*-}(892)\nu_\tau$ †

J. M. Dorfan, C. A. Blocker, G. S. Abrams, M. S. Alam, ^(a) A. M. Boyarski,
M. Breidenbach, D. L. Burke, W. C. Carithers, W. Chinowsky, M. W. Coles,
S. Cooper, W. E. Dieterle, J. B. Dillon, J. Dorenbosch, M. W. Eaton,
G. J. Feldman, M. E. B. Franklin, G. Gidal, G. Goldhaber, G. Hanson,
K. G. Hayes, T. Himel, ^(b) D. G. Hitlin, ^(c) R. J. Hollebeek, W. R. Innes,
J. A. Jaros, P. Jenni, ^(b) A. D. Johnson, J. A. Kadyk, A. J. Lankford,
R. R. Larsen, V. Lüth, R. E. Millikan, M. E. Nelson, C. Y. Pang,
J. E. Patrick, M. L. Perl, B. Richter, A. Roussarie, D. L. Scharre,
R. H. Schindler, ^(b) R. F. Schwitters, ^(d) J. L. Siegrist, J. Strait,
H. Taureg, ^(b) M. Tonutti, ^(e) G. H. Trilling, E. N. Vella, R. A. Vidal,
I. Videau, J. M. Weiss and H. Zaccane ^(f)

Stanford Linear Accelerator Center
Stanford University, Stanford, California 94305
and
Lawrence Berkeley Laboratory and Department of Physics
University of California, Berkeley, California 94720

ABSTRACT

This Letter presents a measurement of the branching fraction for the Cabibbo suppressed decay $\tau^- \rightarrow K^{*-}(892)\nu_\tau$ using data obtained with the Mark II detector at SPEAR. Eleven events containing a $K^{*\pm}(892)$ in coincidence with a muon or an electron of opposite charge were found in data which span the center-of-mass energy region $4.2 < E_{c.m.} < 6.7$ GeV. It was determined that $B(\tau^- \rightarrow K^{*-}(892)\nu_\tau) = (1.7 \pm 0.7)\%$. The absence of events at the $K^{*\pm}(1430)$ yields a 2σ upper limit $B(\tau^- \rightarrow K^{*-}(1430)\nu_\tau) < 0.9\%$.

(Submitted to Physical Review Letters)

† Work supported in part by the Department of Energy, under contracts DE-AC03-76SF00515 (SLAC) and W-7405-ENG-48 (LBL), by Deutsch Akademische Austausch Dienst, Bonn, Germany and Ecolé Polytechnique, France.

Present Addresses:

- (a) Vanderbilt University, Nashville, TN 37235
- (b) EP Division, CERN, Geneva, Switzerland
- (c) California Institute of Technology, Pasadena, CA 91125
- (d) Harvard University, Cambridge, MA 02138
- (e) Universität Bonn, Federal Republic of Germany
- (f) Centre d'Etudes Nucleaires de Saclay, Gif-sur-Yvette, France.

We present herein a measurement of the branching fraction for the decay¹ $\tau^- \rightarrow K^{*-}(892) \nu_\tau$, which constitutes the first measurement of a Cabibbo suppressed decay of the τ . Recently² we published a measurement of the branching fraction for the Cabibbo favored decay $\tau^- \rightarrow \rho^- \nu_\tau$ which is in good agreement with the theoretical expectation based on a weak vector hadronic coupling. The presence of the Cabibbo suppressed decay $\tau^- \rightarrow K^{*-} \nu_\tau$ and its measured rate adds further support to the notion that the standard weak vector hadronic current mediates the decays of the τ . We also present a 2σ upper limit for the decay $\tau^- \rightarrow K^{*-}(1430) \nu_\tau$.

The measurement is based on all Mark II SPEAR data with $4.2 < E_{\text{c.m.}} < 6.7$ GeV. The energy threshold of 4.2 GeV is chosen to avoid those regions where production of D mesons could constitute a significant background. The data represent a total of $14,600 \text{ nb}^{-1}$ with most of the running occurring between 4.2 and 5.2 GeV. This luminosity, when converted using the theoretical cross section, corresponds to 40,200 produced $\tau^+ \tau^-$ pairs.

All aspects of the Mark II solenoidal detector pertinent to this measurement have been fully discussed elsewhere.³ The $\tau^- \rightarrow K^{*-} \nu_\tau$ decay is identified by the following topology:

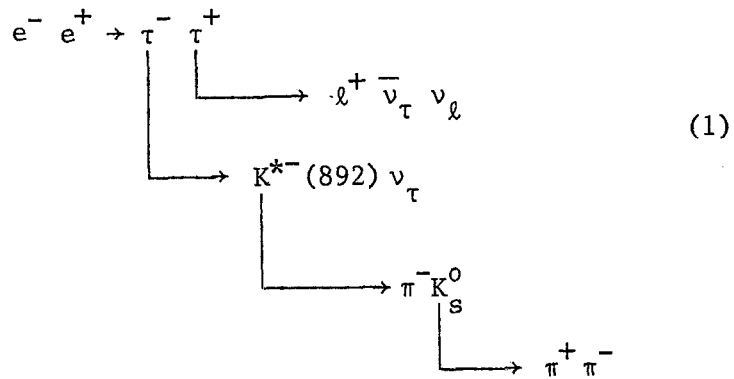

which results in four charged particles in the detector. The symbol ℓ^- represents either an electron or a muon. The selection criteria for the leptons are identical to those used in the analysis of $\tau^- \rightarrow \rho^- \nu_\tau$ and are discussed in Ref. 2. Events are required to have four charged particles, two positive and two negative, and no photons with $E_\gamma > 100$ MeV. Two of the charged particles are required to be consistent with the decay $K_S^0 \rightarrow \pi^+ \pi^-$. The reconstruction techniques used for the K_S^0 are fully covered in Ref. 4. Briefly, secondary vertices are formed at the point of closest approach between particles of opposite sign. This crossing point is evaluated in the plane transverse to the beam direction; the distance between the primary and secondary vertices is required to lie between 1 cm and 30 cm. The directions of the particles are corrected to the radial crossing point and the momenta are corrected for dE/dx losses. A final candidate cut requires that the K_S^0 direction, as measured by its momentum, agree within measurement errors with the direction calculated from the position of the beam interaction point and the secondary vertex position. Fig. 1 shows the $\pi^+ \pi^-$ invariant mass spectrum for secondary vertices found in the event topology described above. A ± 30 MeV mass cut is made for these K_S^0 candidates and a 1C fit to the K_S^0 mass is performed. A χ^2 cut of 10 is made for this analysis. The resulting detection efficiency, including the branching ratio $B(K_S^0 \rightarrow \pi^+ \pi^-)$, is approximately 20%, independent of the K_S^0 momentum. The position of the primary vertex formed by the two particles which do not come from the K_S^0 decay is required to be consistent with the known position of the beam interaction point. Cuts of ± 10 cm along the beam direction and 2 cm radially are applied.

Seventy-nine events survive the selection criteria described above. If we label both the particles at the primary vertex as π 's then we can form two $K_S^0 \pi^\pm$ invariant mass combinations. These mass combinations are shown in Fig. 2. A signal at the $K^*(892)$ mass is seen above background. The background in Fig. 2 arises from double counting ($\sim 65\%$), feeddown from multihadronic events ($\sim 15\%$) and hadronic four-prong events in which two of the tracks pass the K_S^0 requirements because of measurement errors. In order to remove the background due to double counting and substantially reduce the hadronic backgrounds, we require that one of the tracks at the primary vertex be a lepton. This requirement also strongly enhances the probability that the K^* arises from τ decay. Fig. 3 is the invariant mass spectrum of the K_S^0 and the π^\pm for events containing a lepton. A clear excess of events is present at the $K^*(892)$ mass. We attribute these K^* -lepton coincidences to the decay topology outlined in (1). From the 11 events in the 5 bins from $825-950 \text{ MeV}/c^2$ we have subtracted a background of 2.0 events as obtained from the 10 surrounding bins. This leaves a signal of 9.0 ± 3.6 events. Of the 11 events, 7 have an electron tag and 4 a muon tag which is consistent with the relative electron/muon tagging efficiency of ~ 1.6 . The momentum spectrum for the lepton tags and for the K^* 's is well reproduced by the Monte Carlo program which assumed a $\tau^+ \tau^-$ production process. In particular, the lepton momentum spectrum is "hard": 9 of the 11 leptons have momenta above $700 \text{ MeV}/c$ and all the muons have momenta above $1.0 \text{ GeV}/c$.

Since D meson decays give rise to both leptons and strange particles, it is important to establish that the $K^{*\pm} \ell^\mp$ events do not arise from charm production. Since we see no events of the type $K^{*\pm} \ell^\pm$, we can assume that

in most of the $K^{*\pm}\ell^{\mp}$ events there are no missing (undetected) charged particles. Charm events have relatively high charged and neutral particle multiplicities. This fact, coupled with the good solid angle coverage of the Mark II detector, makes it very difficult for charm events to populate the low-multiplicity $K^{*\pm}\ell^{\mp}$ -no-photon topology. The decay $D^{\pm}\rightarrow K^{*\pm} + \text{neutrals}$ is forbidden by the $\Delta S = \Delta C$ selection rule, and thus does not represent a background problem. An example of a possible source of background is $e^+e^- \rightarrow D^0\bar{D}^0$ where $D^0 \rightarrow \ell^{\pm}K^{*\mp} + \text{neutrals}$ and $\bar{D}^0 \rightarrow \text{all neutrals}$. The data rule out this possibility because 7 of 11 events have the $K^*\ell$ invariant mass ($M(K^*\ell)$) above the D mass and two of the remaining events have $M(K^*\ell) > 1.6 \text{ GeV}/c^2$. D's, which result from $D\bar{D}$ and $D^*\bar{D}^*$ production and which are the most probable source of the K^* and lepton, are accompanied by pions and photons and therefore do not populate the low multiplicity $K^*\ell$ -no-photon event category. A Monte Carlo simulation program has been used to estimate that charmed particle production contributes at most 0.1 events to the $K^{*\pm}\ell^{\mp}$ sample. The leptons which come from the semileptonic D decays, as simulated by the Monte Carlo programs, have a momentum spectrum which is much "softer" than that observed in the $K^*\ell$ events. Almost all these leptons would have momenta below 700 MeV/c, in strong contrast to the data.

The detection efficiency for the $K^*\ell$ events was obtained from a Monte Carlo program which produced raw data for decays of the type described in (1). These events were then passed through the identical reconstruction programs as the data and in particular the same K_S^0 selection criteria were applied to the Monte Carlo events. The efficiencies for the K^* -electron and K^* -muon events are 2.1% and 1.3%, respectively. In contrast to electrons which are identified at all

momenta, muons cannot be identified below 700 MeV/c. Combining these efficiencies, the number of produced $\tau^+\tau^-$ pairs and the number of signal events, we obtain

$$B(\tau^- \rightarrow K^{*-} \nu_\tau) \cdot B(\tau^- \rightarrow \ell^- \bar{\nu}_\ell \nu_\tau) = 0.0031 \pm 0.0013 \quad .$$

Using the Mark II measurement² of

$$B(\tau^- \rightarrow \ell^- \bar{\nu}_\ell \nu_\tau) = (18.5 \pm 1.5)\%$$

and assuming electron-muon universality in τ decays,⁵ we obtain

$$B(\tau^- \rightarrow K^{*-} \nu_\tau) = (1.7 \pm 0.7)\% \quad .$$

The quoted error contains the statistical uncertainty and systematic uncertainties of 5% for lepton misidentification, 6% for luminosity and 10% for the Monte Carlo efficiency. The data are corrected for initial state radiation effects which amount to 2.2%. There are no $K^{*\pm}\ell^\mp$ events in the mass region of the $K^*(1430)$ which allows us to set a 2σ upper limit

$$B(\tau^- \rightarrow K^{*-}(1430) \nu_\tau) < 0.9\% \quad .$$

Since the $K^*(1430)$ is a spin-2 particle, this decay is forbidden in any V/A theory.

It is worth noting that the excess of $K^*(892)$ mass combinations in Fig. 2 (no lepton tag) can be accounted for by the decay $\tau \rightarrow K^* \nu_\tau$. Using $B(\tau \rightarrow K^* \nu_\tau)$ obtained above, we would expect a contribution of 23 ± 9 K^* mass combinations in Fig. 2 which is in good agreement with the background corrected signal of 23.5.

As a check on the above data we searched for events in which the $K^{*\pm}$ was identified via the decay mode $K^{*\pm} \rightarrow K^\pm \pi^0$, with a lepton tag

required. The K^\pm were identified with the time-of-flight system³ and the π^0 's were reconstructed from photons in the liquid argon barrel modules.² Because of the low π^0 efficiency coupled with K^\pm losses due to decays in flight, this mode of detection has an efficiency of 25% relative to the $K_S^0 \pi^\pm$ mode. Hence, based on the number of $K_S^0 \pi^\pm \ell^\mp$ events we would expect to see $2.3 \pm 0.9 K^\pm \pi^0 \ell^\mp$ events. There are three events in the mass region from 825–975 MeV/c² and virtually no background. These data constitute a statistically weak signal. However, they offer confirmation of the signal found with the decay $K^{*\pm} \rightarrow K_S^0 \pi^\pm$.

The most naive theoretical expectation for the $\tau \rightarrow K^* v_\tau$ branching fraction is

$$B(\tau \rightarrow K^* v_\tau) = \tan^2 \theta_c B(\tau \rightarrow \rho v_\tau)$$

where θ_c is the Cabibbo angle. A more detailed calculation of Tsai⁶ yields

$$B(\tau \rightarrow K^* v_\tau) = \tan^2 \theta_c \cdot B(\tau \rightarrow \rho v_\tau) \cdot F_{K^*}/F_\rho \quad (2)$$

where

$$F_j = \left(1 - (M_j/M_\tau)^2\right)^2 \cdot \left(1 + 2(M_j/M_\tau)^2\right)$$

We can use two independent measures for $B(\tau \rightarrow \rho v_\tau)$ to evaluate (2). Tsai⁷ has calculated $B(\tau \rightarrow \rho v_\tau) = (21.5 \pm 1.8)\%$ assuming the conserved vector current hypothesis and the measurement⁸ $\Gamma(e^+ e^- \rightarrow \rho^0) = (5.8 \pm 0.5)$ KeV, where the error in $B(\tau \rightarrow \rho v_\tau)$ reflects the uncertainty in $\Gamma(e^+ e^- \rightarrow \rho^0)$. For $\tan^2 \theta_c = 0.05$ and $M_\tau = 1.782$ GeV/c² one obtains⁹ $B(\tau \rightarrow K^* v_\tau) = (1.0 \pm 0.1)\%$. Alternatively we can use the Mark II measurement² $B(\tau \rightarrow \rho v_\tau) = (20.5 \pm 4.1)\%$ to obtain $B(\tau \rightarrow K^* v_\tau) = (0.95 \pm 0.19)\%$. The experimental measurement presented in this Letter agrees well with both these predictions.

This work was supported in part by the Department of Energy, under contracts DE-AC03-76SF00515 (SLAC) and W-7405-ENG-48 (LBL). Support for individuals came from the listed institutions plus Deutsche Akademische Austausch Dienst, Bonn, Germany and Ecolé Polytechnique, France.

REFERENCES

- (a) Present address: Vanderbilt University, Nashville, TN 37235.
- (b) Present address: EP Division, CERN, Geneva, Switzerland.
- (c) Present address: California Institute of Technology, Pasadena, CA 91125.
- (d) Present address: Harvard University, Cambridge, MA 02138.
- (e) Present address: Universität Bonn, Federal Republic of Germany.
- (f) Present address: Centre d'Etudes Nucleaires de Saclay,

Gif-sur-Yvette, France.

1. The notation $\tau^- \rightarrow \rho^- \nu_\tau$ and $\tau^- \rightarrow K^{*-} \nu_\tau$, used throughout the text, imply also the charge conjugate reactions $\tau^+ \rightarrow \rho^+ \bar{\nu}_\tau$ and $\tau^+ \rightarrow K^{*+} \bar{\nu}_\tau$.
2. G. S. Abrams et al., Phys. Rev. Lett. 43, 1555 (1979).
3. G. S. Abrams et al., Phys. Rev. Lett 43, 477 (1979)
4. R. H. Schindler, SLAC-REPORT-219, May 1979, Ph.D. dissertation.
5. Because the lepton tagging criteria are identical for both this analysis and that of Ref. 2, systematic effects in lepton identification tend to cancel. For this reason, we use $B(\tau^- \rightarrow \ell^- \bar{\nu}_\ell \nu_\tau)$ from Ref. 2 rather than a world average.
6. Y. S. Tsai, Phys. Rev. D4, 2821 (1971).
7. Y. S. Tsai, SLAC-PUB-2450, (to be published in the Proceedings of the Guangzhou Conference on Theoretical Particle Physics, January 5-14, 1980).
8. D. Benaksas et al., Phys. Lett. 39B, 289 (1972).
9. The calculation $B(\tau^- \rightarrow K^{*-} \nu_\tau) = 1.46\%$ in Ref. 7 differs from that quoted herein because the author uses $\tan^2 \theta_c = 0.073$.

FIGURE CAPTIONS

1. $\pi^+\pi^-$ invariant mass spectrum for events containing four charged particles and no photons.
2. $K_S^0\pi^\pm$ invariant mass spectrum using both tracks at the primary vertex.
3. $K_S^0\pi^\pm$ invariant mass spectrum for events which have a lepton at the primary vertex.

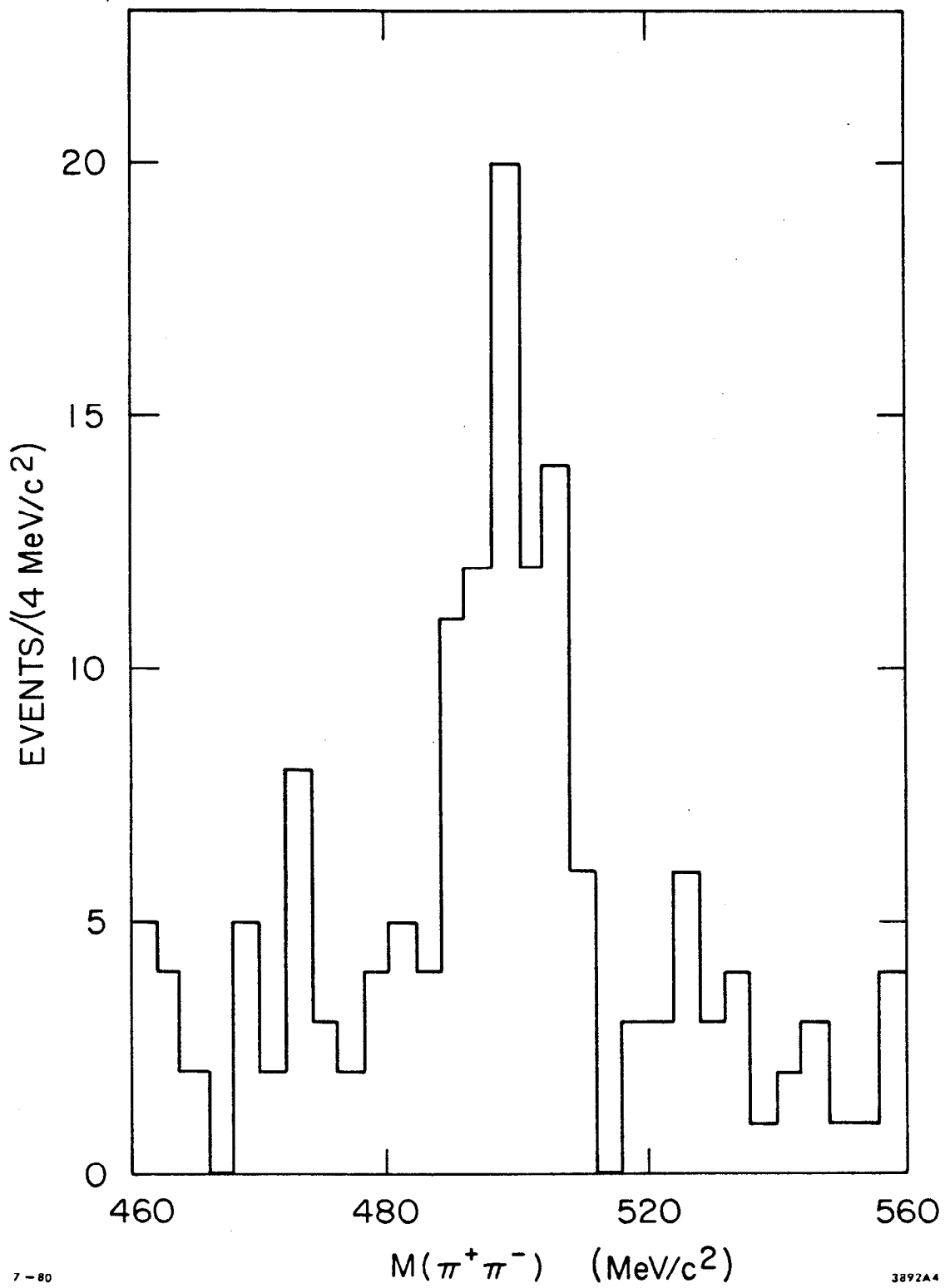
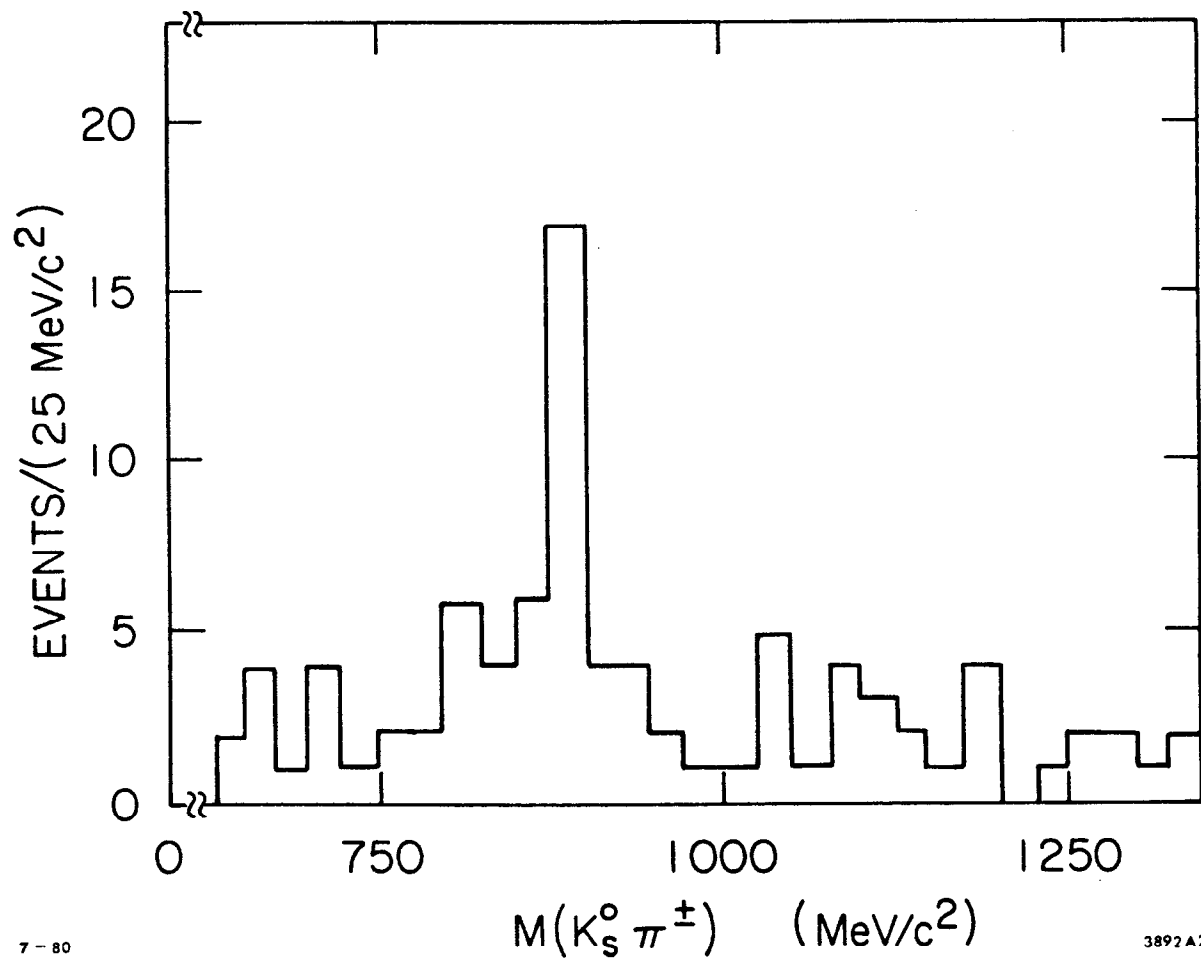

Fig. 1



7-80

3892 A2

Fig. 2

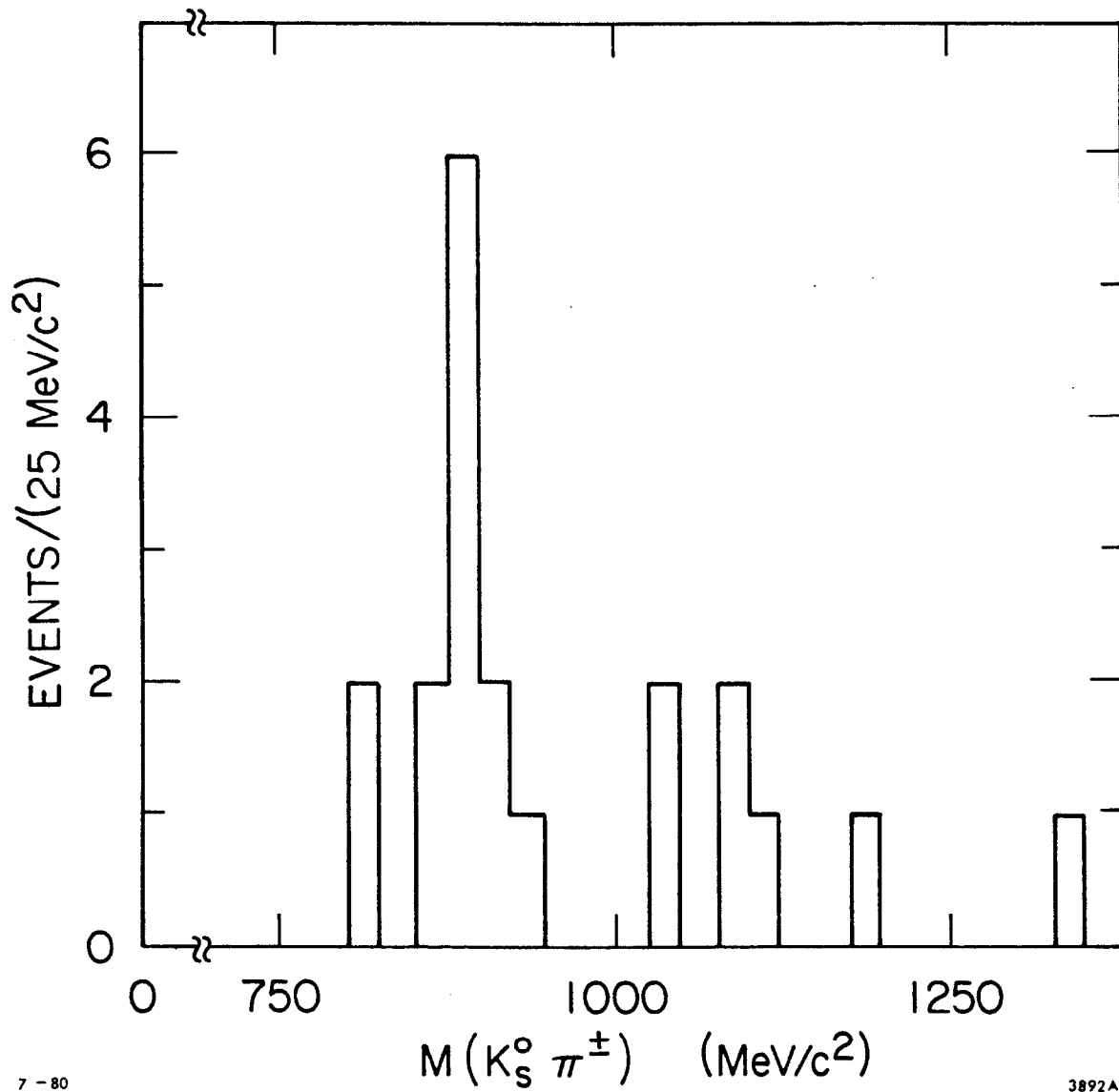

Fig. 3