

A LONGITUDINAL FEEDBACK SYSTEM FOR PEP*

M. A. Allen, M. Cornacchia†, and A. Millicht††
 Stanford Linear Accelerator Center, Stanford, California 94305

1. Coupled Bunch Longitudinal Oscillations and Beam Spectrum

In PEP, two counter-rotating beams (one of e^+ , the other of e^-) of three bunches each collide at six interaction points. The frequency spectrum of one of the beams formed by three equally spaced and equally populated bunches is a series of lines spaced by $3\omega_0$ where $\omega_0 = 2\pi/T_0$ is the angular revolution frequency ($f_0 = \omega_0/2\pi = 136.27$ kHz for PEP). When longitudinal coupled bunch oscillations are driven in the beam by parasitic impedances in the ring, new lines show up in the spectrum about the harmonics of the revolution frequency and Ω (angular synchrotron frequency) apart (Fig. 1). Pellegrini and Sands¹ show that the lines

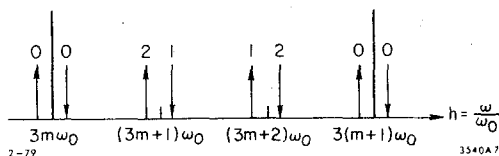

Fig. 1. Portion of current spectrum showing longitudinal modes sidebands for a beam of three bunches.

about the main beam components at $3m\omega_0$, with m integer, are due to the baricentric mode, whereas the lines about the two intermediate harmonics of the revolution frequency at $(3m+1)\omega_0$ and $(3m+2)\omega_0$ are caused by the other two fundamental modes of oscillations of the three bunches. Their theory predicts that the lower sidebands in the spectrum are damped (upward arrow in Fig. 1) while the upper sidebands are anti-damped (downward arrow). This means that the voltage induced in a resistive impedance of the ring by the beam current component at the lower sideband of a mode has the effect of damping the mode, while the voltage induced by the upper sideband has the effect of exciting the mode. It appears that in order to stabilize a particular mode, the sum of all resistive impedances in the ring at the upper sidebands of the mode has to be made lower than the sum of the impedances at the lower sidebands. This can be done by introducing a strong damping term in this second sum. For the baricentric mode, the damping term is introduced by detuning the main accelerating cavities towards $\omega_{RF} - \Omega$ thus increasing the resistive impedance at the lower sideband and decreasing it at the upper sideband of this mode since $\omega_{RF} = h\omega_0 = 3h'\omega_0$ with h' integer.

It has been shown by Pellegrini and Sands that the detuning of the main RF cavities has the secondary effect of anti-damping one of the other two fundamental modes and that either one of these is driven unstable by the parasitic impedances of the main PEP accelerating cavities. The feedback system we describe in this paper is designed to stabilize these modes.

2. Measurements of Instability Risetime in SPEAR

In order to obtain some quantitative results and to gain experience with coupled bunch oscillations, we filled 5 equally spaced buckets in SPEAR ($h=280$) with 8 mA of electrons each at 1.88 GeV. We were able to excite longitudinal coupled bunch oscillations by

moving the tuners of the 860 MHz bunch lengthening cavity not powered. The spectrum of the oscillating beam and the position of the cavity impedance in frequency are shown in Fig. 2. In a first experiment, we modulated on and off the power to the cavity thus respectively damping

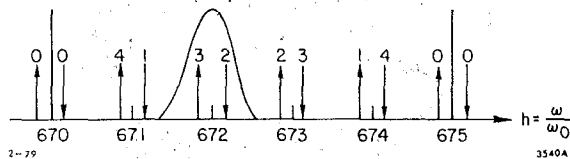

Fig. 2. Portion of current spectrum with longitudinal modes sidebands for a beam of five bunches. Also shown is the impedance of the bunch lengthening cavity in SPEAR.

(by bunch lengthening) and anti-damping the coupled mode 2 oscillation. By filtering and detecting the mode sideband we could measure the instability risetime which was 5 ms at 40 mA beam current. The risetime doubled when the beam current was reduced to 20 mA. We considered the 860 MHz cavity impedance as the prevailing factor to drive the instability and found our result in good agreement with theory.^{1,2}

In a second experiment we used the 860 MHz bunch lengthening system to actively excite and damp the oscillations. The block diagram of the system is shown in Fig. 3. We employed a technique developed at the CERN PS Booster³ except that in our case we used a separate

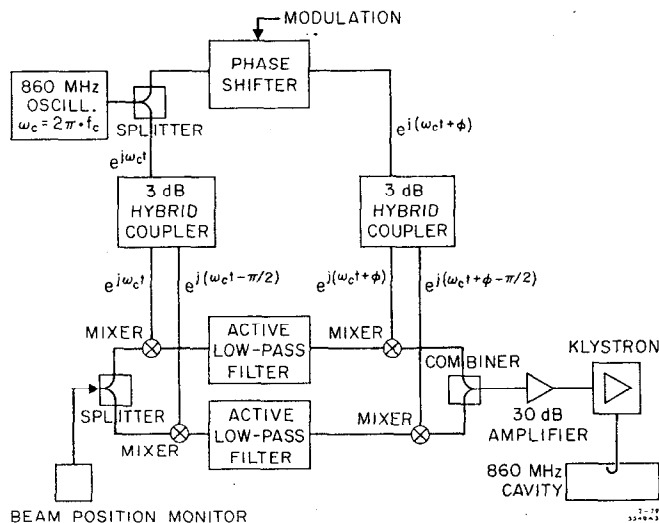

Fig. 3. Frequency domain feedback system, block diagram for one mode.

high Q cavity rather than the RF cavities to act upon the mode. The signal from the beam position monitor contains the spectrum of the oscillations (Fig. 4a); the upper sideband at -30 dBm is 15 dB higher than the lower sideband because mode 2 is being driven. The beam spectrum is mixed down with the carrier signal at 860 MHz ($672 \cdot f_0$ in SPEAR), the upper sideband is filtered and amplified, then mixed up again with the carrier signal. Because of the phase relations in the two-path modulator, only the upper sideband output at the second mixers is retained and used to drive the klystron through an amplifier (Fig. 4b). The phase and amplitude of the driving signal could be adjusted by means of a phase

*Work supported by the Department of Energy under Contract No. EY-76-C-03-0515.

†On leave from CERN, SPS Div.; present address: Brookhaven National Laboratory, Upton, NY.

††On leave from CERN, SPS Div., Geneva, Switzerland.

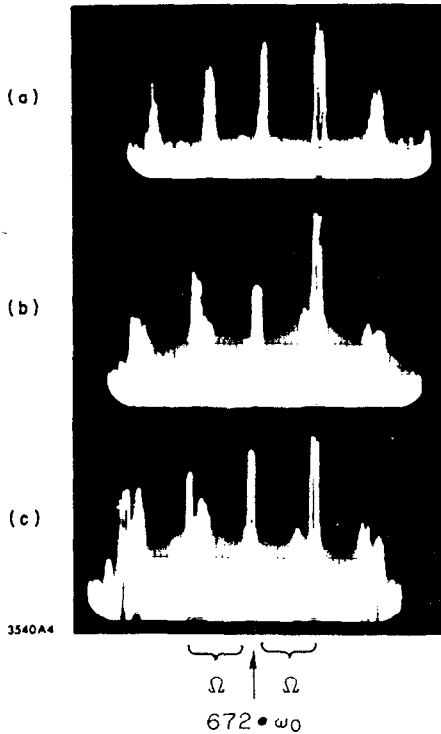

Fig. 4. Spectrum of frequency domain feedback system: a) BPM signal, b) klystron output, c) cavity signal.

shifter and a variable attenuator. We could excite and damp mode 2 with only 700 W at the klystron output, which produces less than 100 kV in the cavity. The spectrum in the cavity is shown in Fig. 4c. We used a square wave generator to shift the phase of the feedback signal by 180° thus damping and anti-damping the oscillation and could measure the risetime of the driven mode. Again we obtained about 5 ms, which is consistent with the value of the driving voltage. The overall gain of the feedback chain was 90 dB.

3. Feedback System Requirements

We consider for PEP a feedback system which consists of a beam position monitor (BPM) sensitive to radial displacement of the bunches and having a good frequency response up to a few GHz, a low level electronic system which processes the BPM signal, a klystron amplifier and a feedback cavity.

The system requirements are as follows:

a) Bandwidth: this can be estimated by considering the spectrum of the two counter-rotating beams of three bunches at a symmetry point in the ring halfway between two consecutive interaction regions. At a symmetry point the bunches arrive at equal intervals $T_0/6 = 1.22 \mu\text{s}$ and the beam frequency spectrum is formed by lines spaced $6 \cdot \omega_0$. When the bunches of both beams present coupled longitudinal oscillations their spectrum appears as in Fig. 5. Each mode sideband is contributed to by bunches of both beams. In order for the feedback system to have enough gain at each mode sideband, the cavity bandwidth (usually the limiting factor) must cover the $6 \cdot f_0 = 817.62 \text{ kHz}$ frequency interval.

The bandwidth requirement can also be assessed by time-domain considerations. If the feedback voltage is to correct the energy error of each bunch individually, then its phase must change in the time interval between bunches. This implies that the field which has acted on one bunch decays to say 5% of its peak value while the field which will act on the subsequent bunch to cross the cavity must rise to say 95% of its peak in that time interval. This imposes for the filling time

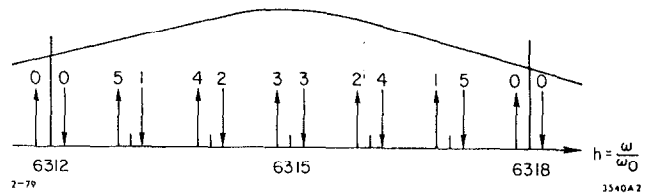

Fig. 5. Portion of current spectrum at a symmetry point for two counter-rotating beams of three bunches each. Also qualitative representation of 860 MHz feedback cavity impedance.

the value $T_f = 0.4 \mu\text{s}$ and on the bandwidth the value $1/(T_f \cdot \pi) = 795 \text{ kHz}$. We have fixed the cavity bandwidth to this last value and chosen a symmetry point for the cavity location in the ring.

b) Gain: this is computed by comparing the risetime of the instability as computed in Ref. 1 with the damping time of the feedback system. The feedback voltage per turn (V_{FB}) per unit relative momentum error (ϵ) for a damping time τ is given by

$$\frac{V_{FB}}{\epsilon} = \frac{2E}{\tau f_0} \quad (1)$$

In the following table we give the results for the two extreme PEP energies. τ_{rad} is the natural radiation damping time and τ is the worst case risetime estimates given in Ref. 1.

Energy (GeV)	τ_{rad} (ms)	τ (ms)	V_{FB}/ϵ (MeV)
4	214	0.5	117.4
15	4	2.6	84.7

The maximum allowable energy deviation of the bunch can be assumed to be $\epsilon_M = 10^{-3}$ which is comparable to the energy spread in the bunch. The corresponding beam radial displacement at a position where $\eta_x \approx 1 \text{ m}$ is

$$\Delta x_M = \eta_x \epsilon_M = 1 \text{ mm}$$

which is well above the sensitivity of the BPM. We have fixed the peak feedback voltage at 300 kV to be on the safe side.

c) Frequency: the selected frequency for the feedback system is 860.540 MHz which corresponds to the harmonic number 6315. The main reasons for going to a frequency higher than the main RF (353.210 MHz) being:

- for a given filling time (bandwidth), cavity length and available power, the voltage increases with frequency
- cavity and waveguide dimensions are correspondingly smaller at higher frequencies
- TV klystrons delivering the amount of power interesting for our application are readily available on the market in the frequency range 470 to 890 MHz.

4. Description of the Feedback System

Two possible ways exist of treating the signal from the beam position monitor to detect the energy oscillations and to produce the feedback signal; they are:

a) Frequency domain: the block diagram of the system for one mode is basically the same as that shown in Fig. 3. The beam spectrum (Fig. 5) is converted to low frequency by mixing with the center frequency 860.540 MHz and then each mode is separated by narrow bandpass filters. By means of the SSB modulator technique one sideband is produced for each mode and it is possible to select for modes 3, 4, 5 the upper sideband and for modes 1 and 2 the lower sideband in the modulation process. By doing so one obtains in the feedback signal only the lines with downward arrows in

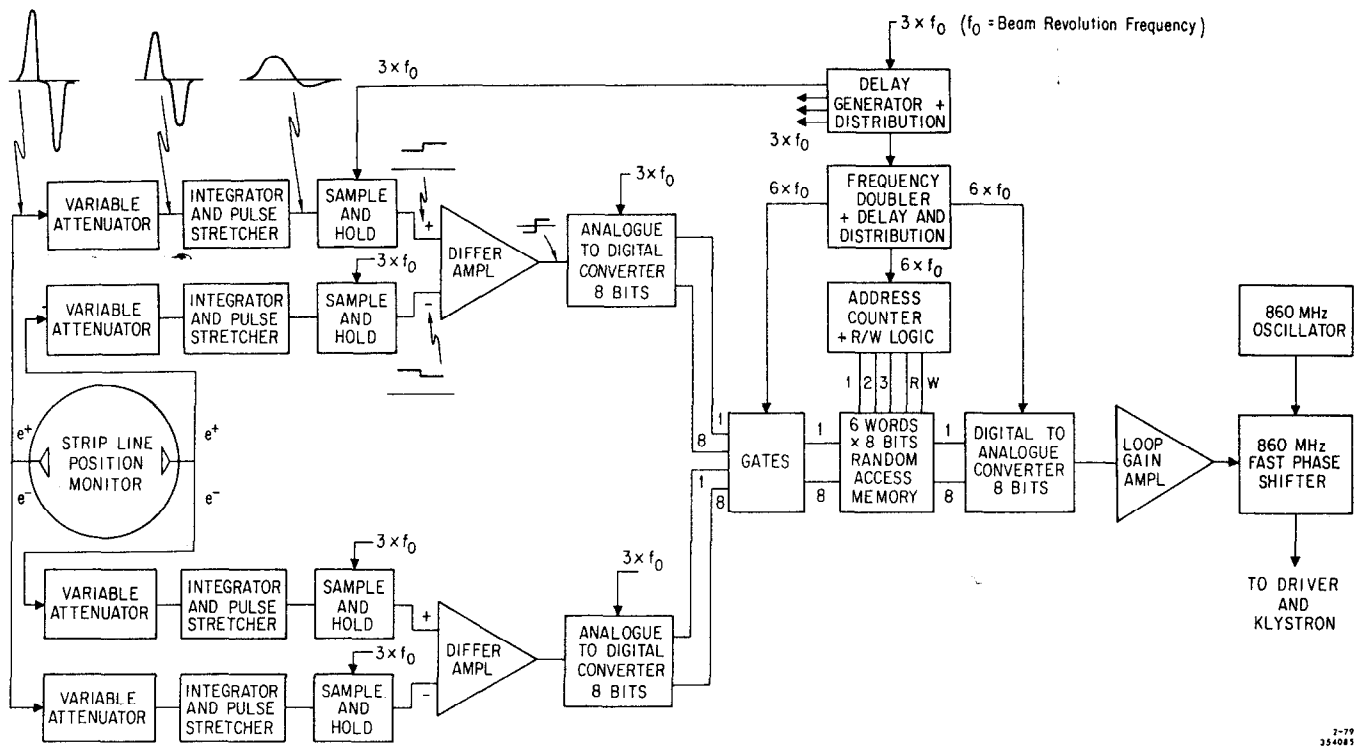

Fig. 6. Time domain feedback block diagram.

Fig. 5, thus clearly separating each mode. The five single sidebands obtained are then summed up, amplified and used to drive the klystron. Provision is made to adjust the amplitude and phase of each feedback frequency individually.

b) Time domain: the block diagram of Fig. 6 is largely self-explanatory. A strip line position monitor is used to separate the pulses from the e^+ and e^- beams. The pulses induced by a bunch in the electrodes are treated in separate channels, they have the same polarity but different levels which depend on the bunch position at the monitor. The difference in pulse height, which is amplified and compensated for closed orbit distortion, results in a signal at the output of the differential amplifier which is converted and stored in a memory location. This is done alternately for the e^+ and e^- bunches so that the storage rate is $6 \cdot f_0$. At the same rate, but with a delay of about one revolution period, the words are fetched from memory and loaded to the D/A converter the output of which drives the varactor diode phase shifter through the loop amplifier. The phase of the 860 MHz wave is modulated between $\pm 90^\circ$ at each bunch traversal as a function of the energy error of the same bunch at the previous passage in the position monitor. The delay of one turn is not significant because of the low value of the synchrotron frequency (between 1 and 7 kHz).

The choice of the BPM location in the ring depends on the type of feedback adopted. The frequency domain system requires the BPM at a symmetry point so that the frequency components of the beam are the same as at the feedback cavity. For the time domain system the BPM should be placed an odd number of horizontal betatron half wavelengths away from the cavity in order to damp simultaneously the radial betatron oscillations.⁴

Both the time and frequency domain systems are being pursued at present since the final choice, based on performance, of either one of them does not affect the characteristics of the amplifier-cavity system.

5. Klystron and Cavity

We have selected the TV klystron type VA-995A by Varian Associates which delivers 55 kW output power in the frequency range 694 to 890 MHz with 50 dB gain and a 1 dB bandwidth of 8 MHz. The power is delivered to the cavity through 500 ft of waveguide type WR975, which introduces attenuation but does not limit the required bandwidth. A drawing of the feedback cavity is shown in Fig. 7; it is a three-cell cylindrical, slot

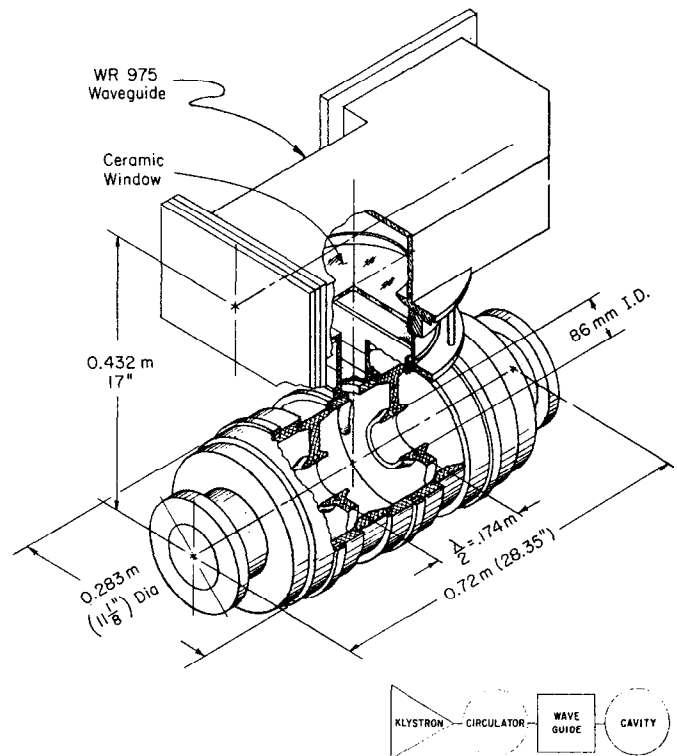

Fig. 7. Feedback cavity for PEP.

coupled, π -mode cavity. The expression of the cavity voltage as a function of input power P and cavity length L is:

$$V = \left(\frac{2\beta}{1+\beta} \right)^{\frac{1}{2}} \left[(\omega T_f) \left(\frac{R}{Q_0} \right) LP \right]^{\frac{1}{2}} \quad (2)$$

where β is the coupling coefficient, R the unitary shunt impedance and Q_0 the unloaded quality factor. For a filling time $T_f = 0.4 \mu s$ and a $Q_0 = 26,000$, the loaded quality factor is $Q_L = 1081$ and the coupling coefficient $\beta = Q_0/Q_L - 1 = 22.6$. The design of the cavity has been optimized to give a high R/Q_0 value of 1080.⁵ The available power at the cavity input being reduced to 40 kW because of the waveguide losses, the voltage in the cavity is computed from (2) to be $V = 305$ kV. The cavity is heavily overcoupled and the reflected power is sent to a load by means of a circulator, which protects the klystron.

6. Conclusion

Whether the wide bandwidth longitudinal feedback system described in this paper is made to act on the individual modes in frequency domain or on the individual bunches in time domain, it represents a clean and efficient way of damping the longitudinal oscillations without influencing other beam parameters such as bunch shape or synchrotron frequency distribution. The frequency domain feedback presents the advantage of providing information on which modes are unstable and on their risetimes, which may be helpful in locating dangerous resonators in the ring.

Acknowledgments

The authors gratefully acknowledge the collaboration of L. Karvonen, J.-L. Pellegrin, and H. Schwarz.

References

1. C. Pellegrini and M. Sands, "Coupled bunch longitudinal instabilities," SLAC technical note PEP-258.
2. F. J. Sacherer, IEEE Trans. Nucl. Sci. NS-90, 825 (1973).
3. B. Kriegbaum and F. Pedersen, IEEE Trans. Nucl. Sci. NS-24, No. 3 (June 1977).
4. A. W. Chao, P. L. Morton, and J. R. Rees, "Single feedback systems for simultaneous damping of horizontal and longitudinal coherent oscillations," (these proceedings).
5. J. Weaver and P. Wilson, "Design of a longitudinal feedback cavity for PEP," SLAC technical note PTM-184 (unpublished).