

ONE NANOSECOND PULSED ELECTRON GUN SYSTEMS*

Roland F. Koontz

Stanford Linear Accelerator Center
 Stanford University, Stanford, California 94305

At SLAC there has been a continuous need for the injection of very short bunches of electrons into the accelerator. Several time-of-flight experiments have used bursts of short pulses during a normal 1.6 microsecond rf acceleration period. Single bunch beam loading experiments¹ made use of a short pulse injection system which included high power transverse beam chopping equipment. Until the equipment described in this paper came on line, the basic grid-controlled gun pulse was limited to a rise time of 7 nanoseconds and a pulse width of 10 nanoseconds. The system described here has a grid-controlled rise time of less than 500 picoseconds, and a minimum pulse width of less than 1 nanosecond. Pulse burst repetition rate has been demonstrated above 20 MHz during a 1.6 microsecond rf accelerating period. The order-of-magnitude increase in gun grid switching speed comes from a new gun design which minimizes lead inductance and stray capacitance, and also increases gun grid transconductance. These gun improvements coupled with a newly designed fast pulser mounted directly within the gun envelope make possible subnanosecond pulsing of the gun.

of 30 volts. Thus, a drive of about 150 volts is required to get a current output of 1 amp from the gun structure. The grid intercepts about 10% of the cathode current. Cathode-anode potential is -70 kVdc.

The internal cone support structure allows the cathode drive connection to be made directly to the cathode electrode. The fast amplifier is designed to fit into this cone, and has a cathode connection socket on its front face with a ring of spring fingers to contact the grid electrode potential of the cone. Fig. 2 shows a picture of the fast pulser board with a cathode-grid structure in place for demonstration purposes.

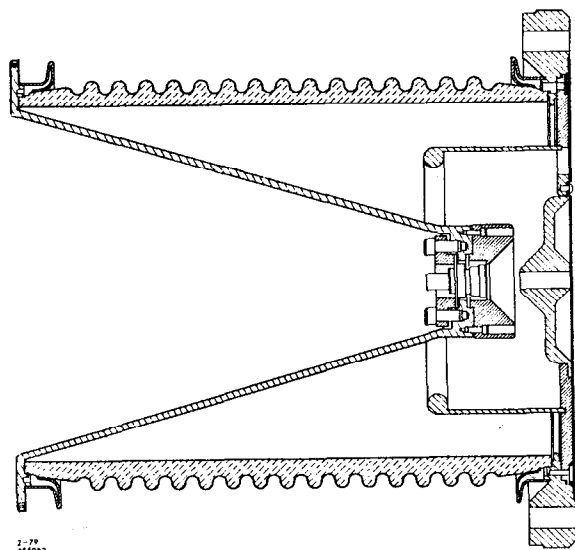

Fig. 1 shows a cross-section of our new fast gun. The cathode-grid structure is taken from a UHF planar triode design, and is supplied by Varian. Two types of cathodes are available, one a standard oxide coated cathode, and the second a dispenser cathode. The dispenser cathode may be let up to an inert atmosphere after conversion without significant loss of emission capability. We started our experiment with the oxide cathode, and have now switched to the dispenser cathode. The anode-grid electrode structure is at the very front of the gun envelope supported by a stainless steel cone inside the ceramic envelope. The grid-cathode-filament structure is coaxial with the vacuum seal being made on the grid electrode. The gun is run as a grounded grid device with the cathode-filament electrodes being driven with a negative pulse from the fast amplifier. The transconductance of the grid-cathode is about 10 millimhos with a cutoff potential

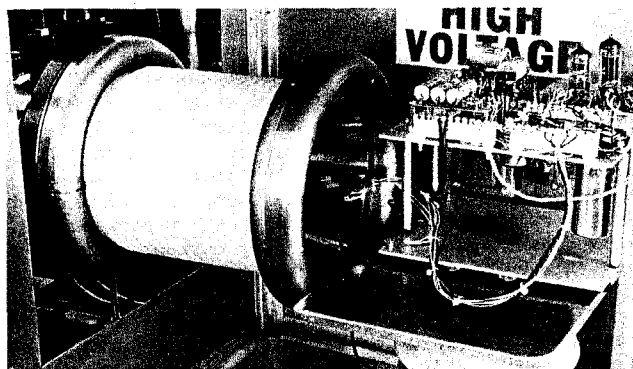
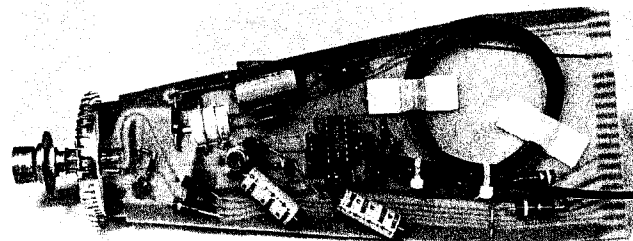
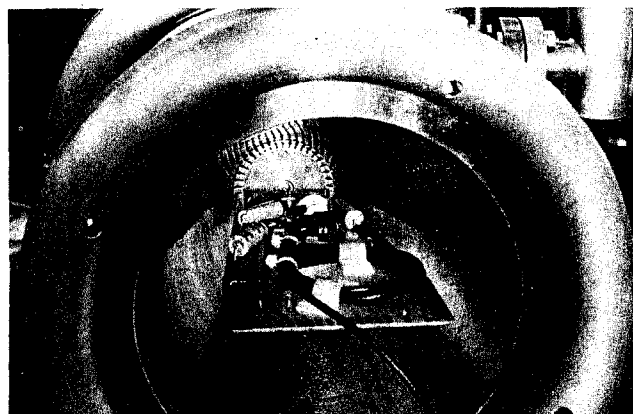
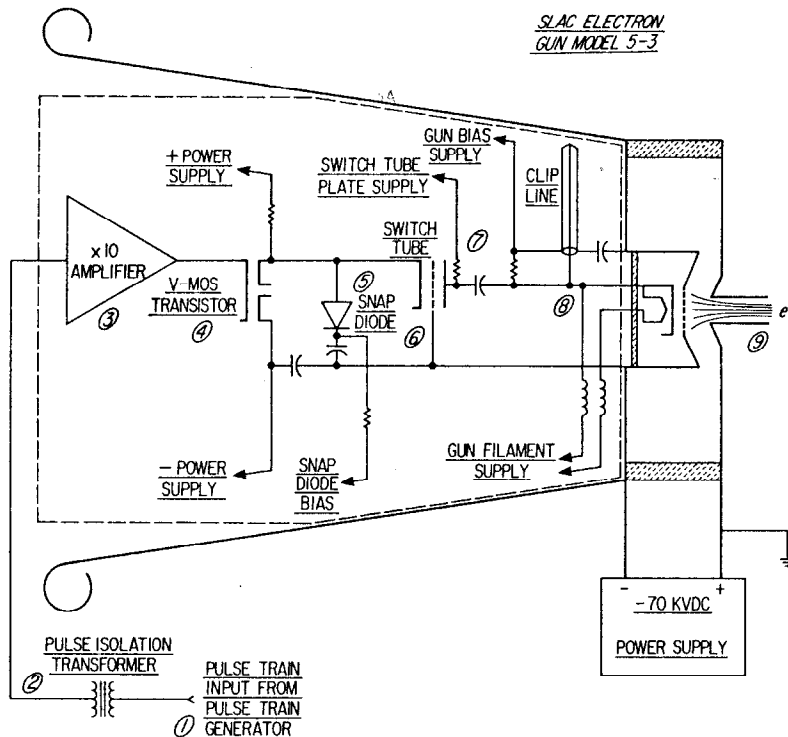

Fig. 3 shows the gun, pulser, and power supply electronics in place in a test facility, and Fig. 4 shows the pulser board in the gun cone.



* Work supported by the Department of Energy under contract number EY-76-C-03-0515.



2-79

3310C1

A block diagram of the pulser board is shown in Fig. 5 (above). The pulse train is generated in low level electronics (1) and delivered to the high voltage gun grid potential through a fast balun-type pulse isolation transformer (2). The level of the pulse train as received at the input to the pulser is 3 volts. A quad transistor IC amplifier (3) boosts the pulse train voltage to 20 volts. This 20 volt pulse train, with pulse rise times of 4 nanoseconds and pulse widths of 8 nanoseconds, is used to switch on the V-MOS transistor (4). The V-MOS transistor switches 2.5 amps with a 4 nanosecond rise time. This 2.5 amps is initially conducted by the snap diode (5) for about 5 nanoseconds. The snap diode then turns off abruptly with a switch-off time of less than 300 picoseconds. This action transfers the 2.5 amp current pulse to the switch tube cathode (8). One amp of this current pulse is delivered from the gun as a 500 picosecond rise time electron beam pulse (9). The 1.1 amp current pulse launched down the clip line returns after 1 to 4 nanoseconds to cancel the cathode current pulse providing for the fall time of the electron beam pulse. Fig. 6 (below) shows a scope photograph of the resulting electron beam pulse taken on a Tektronix 7904 scope with direct access plug-in. Basic rise time of the

scope and beam pickup system is about 500 picoseconds. Fig. 7 (below) shows the pulse train response of the pulser-gun system.

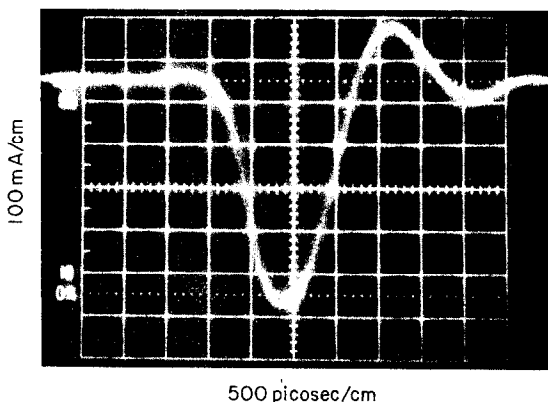
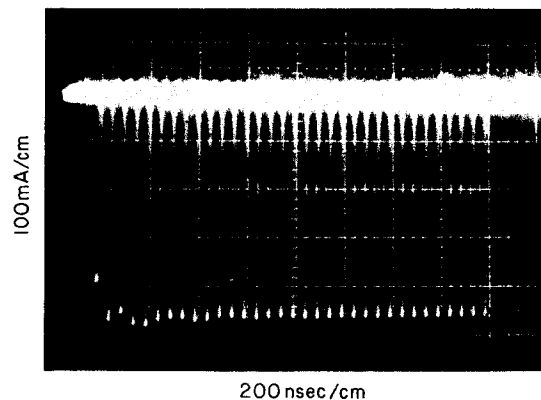

This pulser-gun system is presently installed on the SLAC accelerator and is being used to generate the 1 nanosecond pulses for PEP beam injection tests. We have accelerated up to 600 milliamps in a pulse with less than 500 picoseconds rise time. We plan further studies with this type of a pulser system in conjunction with sub-harmonic bunching to directly load electrons into just one single rf cycle of the accelerator wave. Since this pulser system is dc coupled, we also plan a modified version of this driver without the snap diode to provide conventional 1.6 microsecond beam pulses for the accelerator.

References

1. R. F. Koontz, "Single-Bunch Beam Loading on the SLAC Two-Mile Accelerator," Ph.D. Thesis and Stanford Linear Accelerator Center Report No. SLAC-195, May 1976.