

# COMMISSIONING OF THE FIRST KLYSTRON-BASED X-BAND POWER SOURCE AT CERN

J. Kovermann\*, N. Catalan-Lasheras, S. Curt, S. Doebert, M. Naon, G. McMonagle, E. Paju, S. Rey, G. Riddone, K. Schirm, I. Syratchev, L. Timeo, W. Wuensch, CERN, Geneva, Switzerland  
 A. Hamdi, F. Peauger, CEA, Saclay, France  
 J. Eichner, A. Haase, D. Sprehn, SLAC, Menlo Park, USA

## Abstract

A new klystron based X-band rf power source operating at 11.994 GHz has been installed and started to be commissioned at CERN in collaboration with CEA Saclay and SLAC for CLIC accelerating structure tests. The system comprises a solid state high voltage modulator, an XL5 klystron developed by SLAC, a cavity based SLED type pulse compressor, the necessary low level rf system including rf diagnostics and interlocks and the surrounding vacuum, cooling and controls infrastructure. The system is designed to produce up to 50 MW rf pulses of 1500 ns pulse width and 50 Hz repetition rate. After pulse compression, up to 100 MW of rf power at 250 ns pulse width will be available in the structure test bunker. This paper describes in more detail this setup and the process of commissioning which is necessary to arrive at the design performance.

## INTRODUCTION

The CLIC concept relies on the reliable operation of normal-conducting accelerating structures at 100 MV/m loaded accelerating gradient. Rf breakdowns in these structures limit the achievable luminosity assuming these breakdowns cause beam orbit deviation before collision [1]. To limit excess luminosity loss by this effect, the probability of occurrence has to be lower than  $3 \cdot 10^{-7}$  per rf pulse and meter of active accelerating structure. This probability can be influenced by electromagnetic field geometry design and the choice of material and surface preparation. These effects are not yet fully understood, but several models exist which are under experimental verification [2]. The new CERN X-band power source presented in this paper was built to provide the rf power and infrastructure to condition and then verify the rf performance of newly developed rf structures and components. The setup will also provide possibilities for breakdown physics research taking place in parallel to structure tests.

## SYSTEM OVERVIEW

Figure 1 shows the main components of the X-band power source which are the high voltage modulator, the klystron, the pulse compressor and the structure test bed itself. In addition to this, several systems from low level rf to vacuum interlocks are necessary to operate this power source. All main components and their design

specifications are described in the following sections, more detailed information can be found in [3]. Performance data measured in this setup follows in the commissioning section.

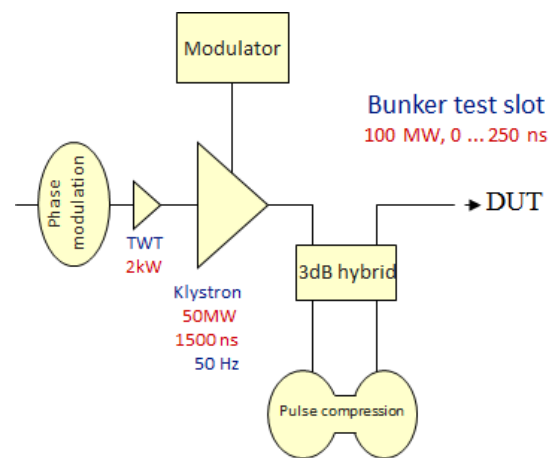

Figure 1: Layout of the CERN X-band power source.

## Klystron

Due to the unavailability in industry of klystrons at the desired power level and frequency at that time, SLAC designed and built under a collaboration agreement with CERN a scaled version of the successful XL4 klystron (developed for NLC). This klystron named XL5 is capable of providing up to 1.5  $\mu$ s long rf pulses of 50 MW at a repetition rate of 50 Hz and 600 W rf drive power. The operating voltage is 400 kV, the nominal perveance  $1.29 \mu\text{A}/\text{V}^{3/2}$  [4].

## Modulator

The klystron is powered by a ScandiNova K2-3 solid state modulator specified to deliver pulses up to 450 kV, 335 A and 1.5  $\mu$ s flat top length at 50 Hz repetition rate [5]. Amongst other things, this modulator has been chosen due to its novel solid state technology and the high integration density, requiring only  $2 \times 3 \text{ m}^2$  of footprint including the klystron oil tank and all supplies, interlocks and controls for the klystron.

## Pulse Compressor

To arrive at 250 ns long rf pulses of 100 MW peak power at the input of the device under test in the testing bunker, the rf output from the klystron has to be compressed. To do so, a short SLED1 type rf pulse compressor has been designed and built by IAP and GYCOM, Russia. Nominally, it can provide a compression of up to a factor of 2.9 in peak power at 1.5  $\mu$ s rf input pulse width [6].

## Rf Network

All high power rf waveguides will operate under vacuum. An over-moded, low loss circular waveguide is used as transmission line from the gallery down to the testing bunker; all other waveguides are in WR90 standard. Further waveguide components are directional couplers for rf diagnostics, vacuum pumping ports, mode converters and a vacuum valve in the over-moded line to be able to keep the network under vacuum while changing the device under test.

## Low Level rf and Additional Infrastructure

The low level rf system provides the pulsed drive power for the klystron with the ability to do the phase modulation necessary for the pulse compression and all data acquisition and control functions. Closely connected to the low level rf system is the interlock system that surveys the rf waveforms, vacuum pressure and modulator status.

## COMMISSIONING

During initial tests, a vacuum leakage developed at the ceramics high voltage feed through of the collector ion pump of the XL5 klystron. In close collaboration with SLAC, the defective ion pump was identified and replaced at CERN. After bake-out, the klystron vacuum recovered completely, but a full rf reconditioning became necessary. Further tests showed an unacceptable increase of beam interception in the klystron body which could later be identified to be a tilted gun baseplate. A total misalignment of 1.5 mm was measured and was confirmed by x-ray inspection of the gun assembly. Without breaking the klystron vacuum, the baseplate was then pressed back into its original position, resulting in full recovery and nominal beam interception.

To recondition the klystron, a simple waveguide network was used, consisting of directional coupler, pumping port and two high power loads being fed by a 3 dB splitter. Reconditioning was done using the standard SLAC procedure for new klystron conditioning. After initial high voltage conditioning without rf, the rf processing was started at the nominal operating voltage of 400 kV. In this processing method, a conditioning step is done at constant rf pulse energy while covering the therefore limited parameter space of pulse length and peak power with reasonably quantified steps. When the klystron operates reliably at any of the possible positions

in this parameter space for more than a given time, the pulse energy is increased and the process is repeated at higher pulse energy.

Due to the unavailability of consistent klystron current and voltage measurements and the after the repairs unknown perveance, a cross-calibration of rf power measurements, collector calorimetry and voltage and current measurements on the primary side of the pulse transformer were necessary to get a consistent set of all operations parameters.

In this configuration, the klystron was conditioned up to 40 MW, 500 ns pulse flat top at 50 Hz repetition rate within  $\sim$ 150 h of operation. The maximum peak power achieved was 50 MW and 300 ns pulse length, the longest pulse 1250 ns, 20 MW flat top power. The gain curve obtained at 400 kV is shown in Fig. 2 in comparison with gain curves taken during the initial conditioning at SLAC. The saturation gain discrepancy at 400 kV can be explained by high voltage measurement uncertainties.

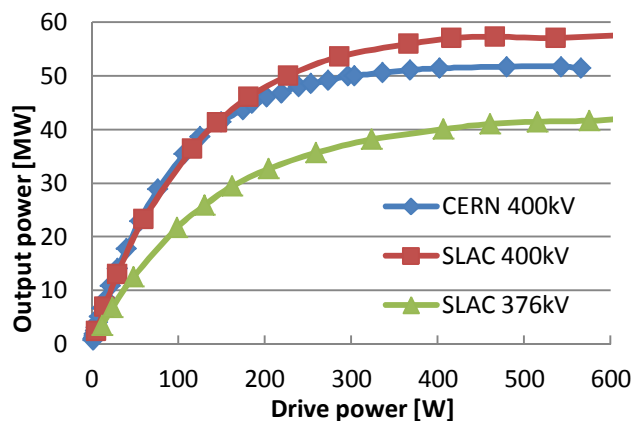

Figure 2: XL5 gain curve measured at SLAC and at CERN after reconditioning.

During the conditioning, rf breakdown occurred mainly in the waveguide components, especially in the directional coupler. Besides occasional breakdowns in the klystron output window, the main limitation in terms of conditioning speed was heavy outgassing in the high power rf loads which disappeared gradually with increasing average rf power and processing time. The repairs on klystron did not have a measurable effect on gun arcing probability. Conditioning was stopped at the end of 2011 following a planned technical stop of the CTF3 facility housing this test stand. This shutdown was used to install the final waveguide network and the pulse compressor and a first structure under test.

## PULSE COMPRESSOR IMPLEMENTATION

### Temperature Stabilization

Due to the high  $Q$ -factor of the SLED1 pulse compressor cavities, a temperature stabilization system had to be designed and implemented to avoid detuning by

ambient temperature changes. Furthermore, the tuning becomes independent of klystron rf output power and its transients. The system was realized using copper blocks with cooling water channels clamped around the cavities and the mode converters (see Fig. 3). To achieve a stability of the compression factor better than 1%, the cooling water has to be stable to 0.1 K. Absolute water temperature can be used for tuning; the calculated frequency sensitivity is -2 MHz/K.

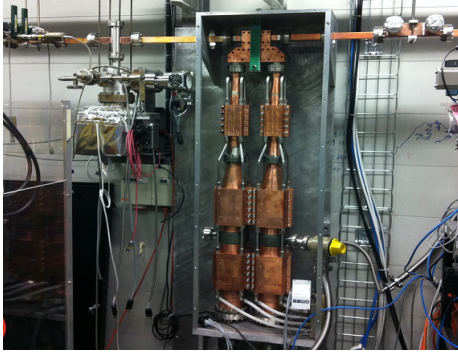

Figure 3: Pulse compressor with temperature stabilization system installed in the test stand.

### Mechanical Tuning System

Initial low power rf tests showed the need for an improved mechanical tuning precision and mechanically limited tuning speed. To do so, the linear actuators for the tuning pistons were equipped with 1:50 reduction gears and precision rotary encoders for absolute position indication. Both linear actuators can be mechanically coupled to allow parallel piston movement. This decreases the chance of accidental uncoupled movement which would result in an immediate harmful increase in reflection back to the klystron. Even at maximum speed of the actuators, the increase in reflection between two rf pulses at 50 Hz repetition rate is sufficiently low not to damage the klystron, but high enough to be intercepted by the interlock system. Control and backlash compensation of the linear actuators is done by the test stand control software.

### Low Power Performance

Figure 4 shows the simulated compressed pulse of an input pulse of 1.5  $\mu$ s length based on S-parameters measured with the pulse compressor in its final position in the test stand. For a 250 ns flat top compressed pulse, the gain in peak power is 2.82 with an optimized phase program. The measured cavity parameters are  $Q_0=1.31 \cdot 10^5$ ,  $Q_{loaded}=2.38 \cdot 10^4$  and  $\beta=4.27$ . The maximum power reflected back to the klystron is -23 dB of the input power. Power loss in the pulse compressor does not exceed 5%, total waveguide line losses from klystron to the input of the device under test have been measured to be 20%.

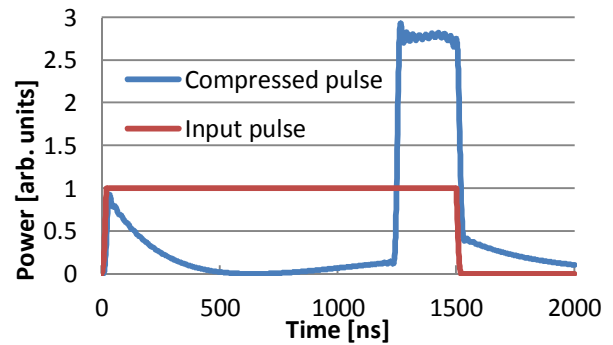

Figure 4: Simulated pulse compressor output pulse (blue) and input pulse (red).

## OUTLOOK

Installation of the final test stand has finished. After thorough testing of all interlock systems, conditioning of the rf network including the pulse compressor can start. The first device under test will be an already installed CLIC T24 structure, requiring 50 MW peak input power to reach 100 MV/m accelerating gradient. Estimating successful rf conditioning of the waveguide network, only 22 MW, 1.5  $\mu$ s long rf pulses will be needed from the klystron for the structure test, allowing operation at decreased collector voltage and heater current, thus improving the lifetime of the klystron.

Once fully commissioned, the test stand will be routinely operated around the clock in automatic mode. The necessary software surveying and controlling the conditioning and testing process of the devices under test has been developed and will be tested in the working setup.

In parallel to the manual conditioning of klystron and waveguide network, an automatic conditioning system for test stand commissioning is under development to support the test stand operators and to allow faster implementation of future test stands.

## ACKNOWLEDGMENTS

CEA Saclay is acknowledged for the significant contribution of the modulator and several high power waveguide parts and SLAC for helping to successfully repair the klystron.

## REFERENCES

- [1] CLIC Conceptual Design Report. In preparation for publication. <http://www.clic-study.org>.
- [2] A. Grudiev et al., Phys. Rev. Spec. Top. Accel. Beams 12 (2009) 102001.
- [3] F. Peauger et al., Proceedings of IPAC10, Kyoto, Japan, THPEB053.
- [4] D. Sprehn et al., SLAC-PUB-14377.
- [5] <http://www.sc-nova.com>
- [6] A.A. Bogdashov et al., Proceedings of RuPAC2010, Protvino, Russia, TUPSA005.